

SYSTEM 25

1. MEASUREMENTS

THE WIDTH AND HEIGHT ARE MEASURED IN THE FOLLOWING MANNER:

W (width) is measured closely at the glass from the left inside edge of the glazing bar to the right edge of the glazing bar, including any rubber or silicon sealing. Measurements are taken at three points in the window wing: on the top, in the middle, the bottom and for production and ordering of the blind then the minimum measured dimension is used. The standard width of the SYSTEM 25 blind is written in below chart, with a tolerance of ± 1 mm. It is recommended to consult with the manufacturer for dimensions outside the stated limits.

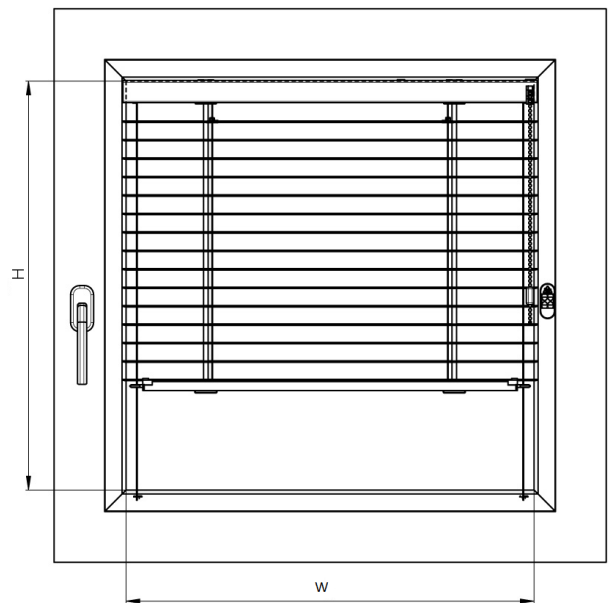

H (height) is measured the same as the width in three points, including sealing. However, in this case the maximum measured dimension is used and is written into the order form. The standard height of the SYSTEM25 blind is written in below chart, with a tolerance of $+20$ mm. It is recommended to consult with the manufacturer for dimensions outside the stated limits.

Type of product	Width (from – to) [mm]	Height (from – to) [mm]	Max. guaranteed area [m ²]
System25 (cord)	300 – 2000	300 – 2200	2,5
System25 (chain)	300 – 2000	300 – 2200	2,5
System25 (handle)	300 – 2000	300 – 2200	2,5
System25 tex. tape (motor)	400 – 2000	300 – 2200	4,4
System25 cord (motor)	600 - 2000	300 – 2200	4,4

D (depth) depth of the glazing bar is measured in relation to the use of the distance pads under the plastic holders of the blinds. Left and right bases are not distinguished.

Depth of the window:

- | | |
|------------------|-------------------------|
| • 20 mm and more | no base |
| • 16 – 20 mm | one base for each side |
| • 12 – 16 mm | two bases for each side |

ATTENTION! When measuring, check the shape and size of the glazing bar to prevent any problems during assembly of the guiding (tightening pins or fixed console).

2. ASSEMBLY

Assemble exactly according to this manual to prevent redundant assembly errors and other related problems.

AIDS FOR ASSEMBLY:

- electric drill, drills, cross-head screwdriver, knife, scissors, pliers

For all wooden windows, the holes must be pre-drilled for the bolts, otherwise, there is a risk of cutting the glazing bar.

The diameters of drills and types of screws are in the following table:

	screw	drill with the diameter Ø
for fixation of the blind with the cover profile	3,9 x 16 3,9 x 25	3 mm
for fixing the holder of the chain	3,9 x 16	3 mm
hole for tightening pin	3,2 mm for plastic and Al windows	3 mm for wooden windows
for fixation of the blind with the cover profile	3,9 x 16	3 mm
for fixing the holder of the chain	3 x 12 3 x 20	2 mm
hole for tightening pin	3,2 mm for plastic and Al windows	3 mm for wooden windows

INSPECTION:

- before assembly we recommend inspecting all the parts after the delivery of the goods to prevent any problems. The manufacturer must be notified of any defects or comments concerning the assembly or blinds.

ASSEMBLY WITH COVER PROFILE (CONSTRUCTION - CHAIN, CORD, HANDLE, ENGINE)

- remove the upper cover profile (if mounted on the grid)
- on the blind in the window wing check if its dimension corresponds to the width of the window; check that the control mechanism is on the right side. If it is necessary to be changed, it is not possible to change it for any System 25 blind. In this case, we recommend contacting the producer. Depending on the depth and shape of the glazing bar, support the blind using the pads. Place the blind to the window wing and screw each holder, using the two screws, into the glazing bar to prevent damage to the frame. The holders are attached to the upper profile in production to ensure the correct position during assembly of the blind on the window wing. If the blind is fitted with a brake (only in the version with a chain) there is a plastic holder between the gearbox and the brake which decreases the control force of the blind and prevents deformation. For the version with the handle, proceed similarly. By locating the holder closely behind the gearbox, it is possible to prevent deformation of the upper profile.
- screws are located into the oval holes on the holder. For wooden windows, the holes are pre-drilled to prevent cutting the glazing bar.
- drill holes for the tightening pins of the leading nylons upwards into the lower part of the glazing bar

If the shape or the size of the glazing bar does not allow drilling holes for the tightening pins into the glazing bar from upwards, choose the option of drilling the holes for pins into the face of the glazing bar. In this case, take care not to damage the glass with the drill. It is important to state the correct depth of the drilling! The client must be informed in advance of this form of assembly and consent in writing in the handing over protocol. Finally, ensure the full functionality of the blind and the window.



Fig. assembly from upwards

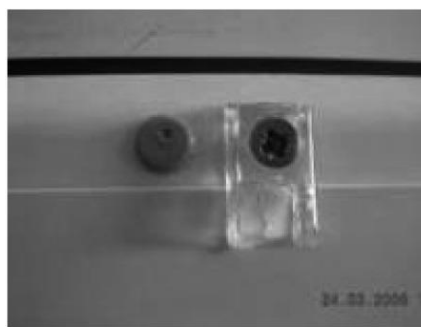

Fig. assembly from the front

- insert the nylon with the knot into the hole and press the pin. When drilling these holes ensure that the span of the holes to the glazing bar for the pin corresponds to the span of the hole in the upper profile to the glazing bar.
- tightening is done by drawing the nylon in the face of the upper profile. Press both pins to arrest the nylon in the tightening status. Cut the redundant ends of the nylon and fix them in the upper profile.

If the blind is not assembled into the glazing bar at 90 degrees and the blind is not in a position that is perpendicular to the glass of the wing, use the component, the so-called pig which is inserted into the hole in the plastic hole until the requested position is reached. Ensure that this component is oriented with the teeth upward. The screws are not tightened fully, the holder is slightly caught, the position is adjusted by the pig and then the screws are tightened.

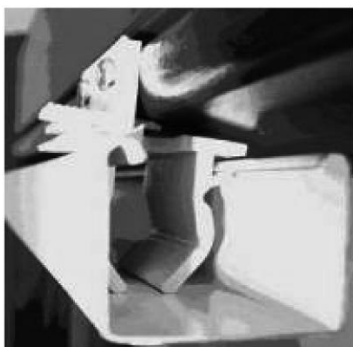

Fig. holder with the pig for the upper cover profile

Then click the upper cover profile with the side covers into the basic profile holders; it must be kept in the plastic holder and must be located symmetrically in the center of the window.

- secure the chain limiter; plastic windows and wooden Euro windows can only be secured into the glazing bar and the holder for fixation of the lever must be mounted for the version with the lever.
- check the function of the blind

ATTENTION!!

Pursuant to the EN 13120:2014 standard, window blinds shall be installed in accordance with the following instructions:

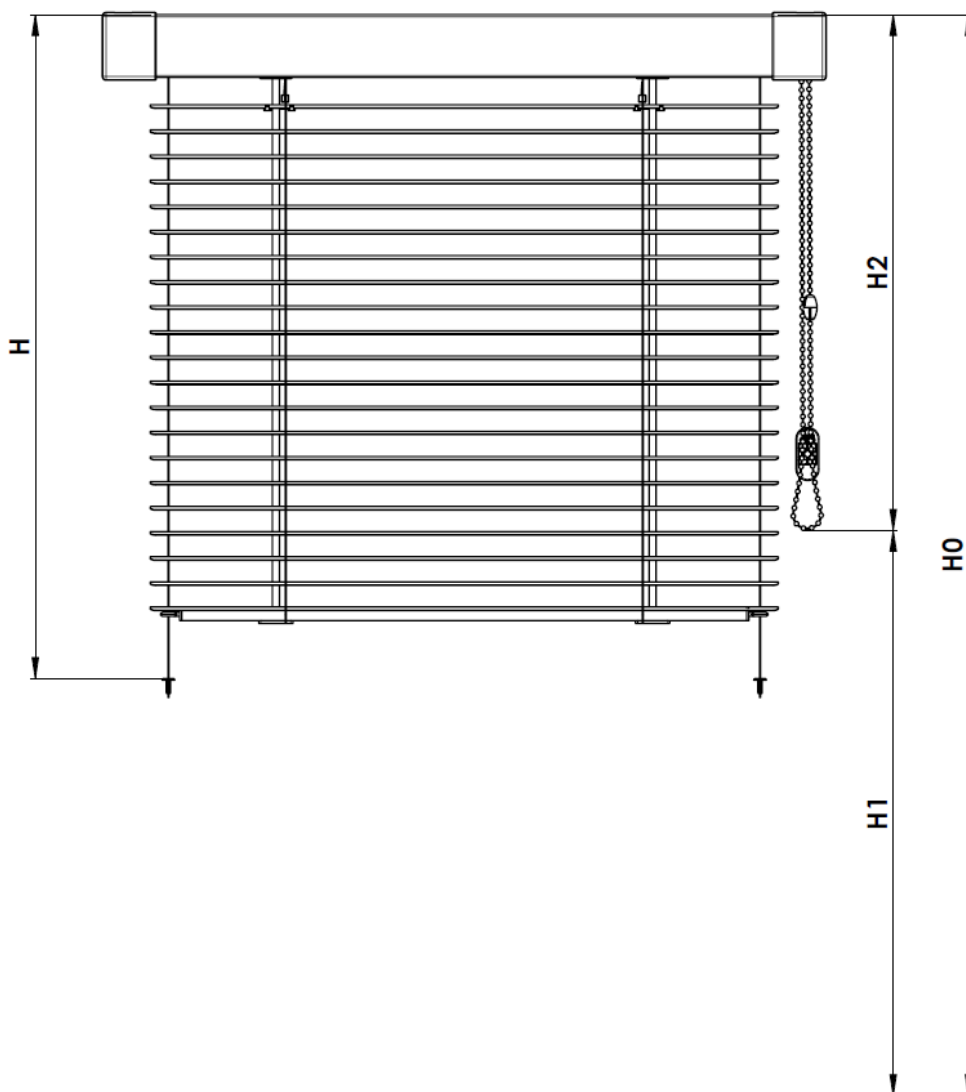
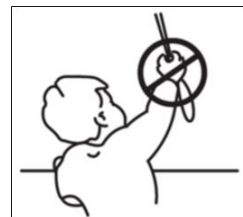

SAFETY FEATURES

CHAIN CONTROL:

a) If a breakaway chain connection is used (for System 25R):

The chain length must be limited as follows:

- 1) If installation height (H0) is not specified:
 - the chain length (H2) shall be less than or equal to 2/3 of the blind height (see previous Fig.): **$H2 \leq 2/3 H$**
- 2) If installation height (H0) is specified:
 - the distance from the floor to the bottom part of the pull cord (H1) shall be at least 0.6 m: **$H1 > 0.6 \text{ m}$**

Chain connection

System 25R without brake

APPLY ONE HALF OF THE COUPLER TO EACH END OF THE CHAIN AND THEN LOCK BOTH COUPLER HALVES.

A dangerous loop must be eliminated when a mass of 6 kg is applied or within 5 seconds of application.

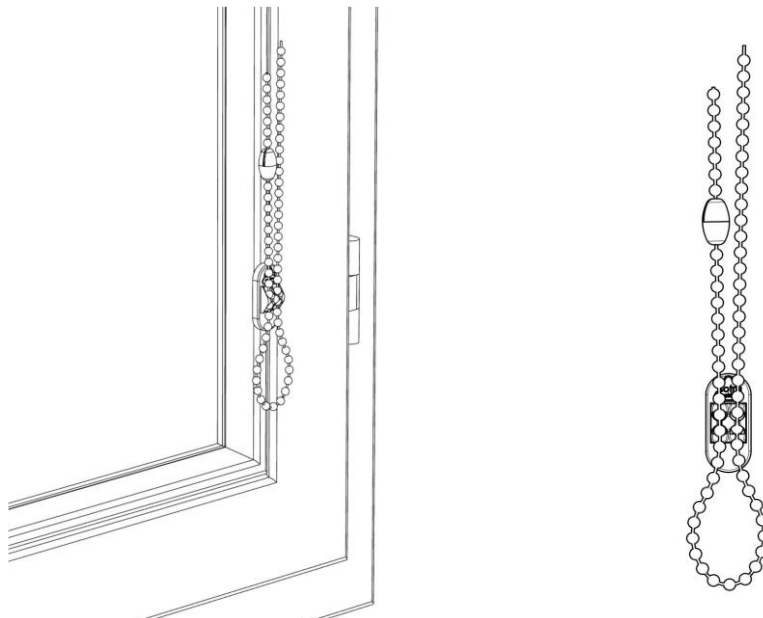

System 25R with brake + chain blinds with an area > than 2.5 m²

FOR CHAIN BLINDS WITH BRAKE, IT IS ALWAYS NECESSARY TO USE AN ENDLESS CORD HOLDER (so-called reel).

b) If a fixed tensioning system (pulley) is used (for System 25L):

The pull cord length must be limited as follows:

- 1) If installation height (H0) is not specified, and
 - if the blind height (H) is less than or equal to 2.5 m, the length of the pull cord(s) (H2) shall be less than or equal to 1 m (see Fig.): **H2 ≤ 1 m**
 - if the blind height (H) exceeds 2.5 m, the length of the pull cord(s) (H2) shall be less than or equal to the height of the blind minus the value of 1.5 m (see Fig. 6): **H2 ≤ H - 1.5 m**
- 2) If installation height (H0) is specified, the distance from the floor to the bottom part of the pull cord(s) (H1) shall be at least 1.5 m (see Fig.): **H1 > 1.5 m**

ATTENTION!! The distance between two loop strands shall not exceed 50 mm at the output from the fixed tensioning device.

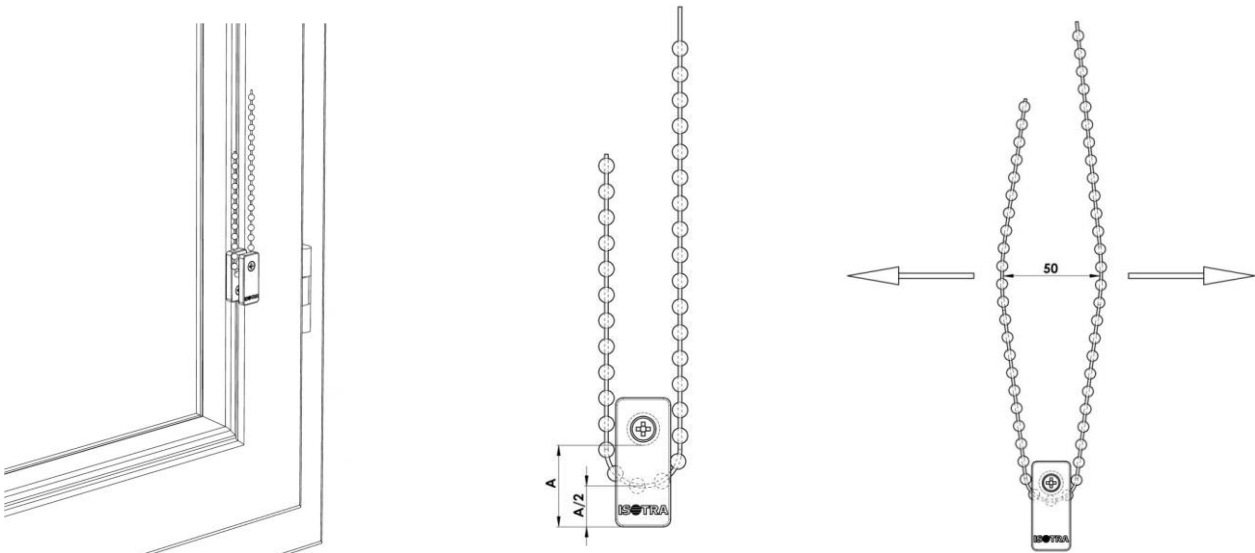

THE PULLEY POSITION SHALL PREVENT EXCESSIVE CHAIN TENSIONING AND THE CHAIN MUST NOT COME OFF!

WHEN PULLED APART, THE GAP BETWEEN THE CHAIN STRANDS SHALL NOT EXCEED 50 mm!

CORD CONTROLS (for System 25S, 25SM, 25SW):

The blinds shall meet the following requirements:

1) If fully pulled up, the pull cord(s) length shall be limited (the two wheels shall be located as follows):

- a) If installation height (H_0) is specified, the distance from the floor to the bottom part of the pull cord(s) (H_1) shall be at least 1.5 m (see Fig.): **$H_1 > 1.5$ m**
- b) If installation height (H_0) is not specified, and
 - if the blind height (H) is less than or equal to 2.5 m
 - the length of the pull cord(s) (H_2) shall be less than or equal to 1 m (see Fig.): **$H_2 \leq 1$ m**
 - if the blind height (H) exceeds 2.5 m
 - the length of the pull cord(s) (H_2) shall be less than or equal to the height of the blind minus the value of 1.5 m (see Fig.): **$H_2 \leq H - 1.5$ m**

2) The pull cords shall meet the following requirements:

- a) In case of two pull cords, the pull cords must never entangle!

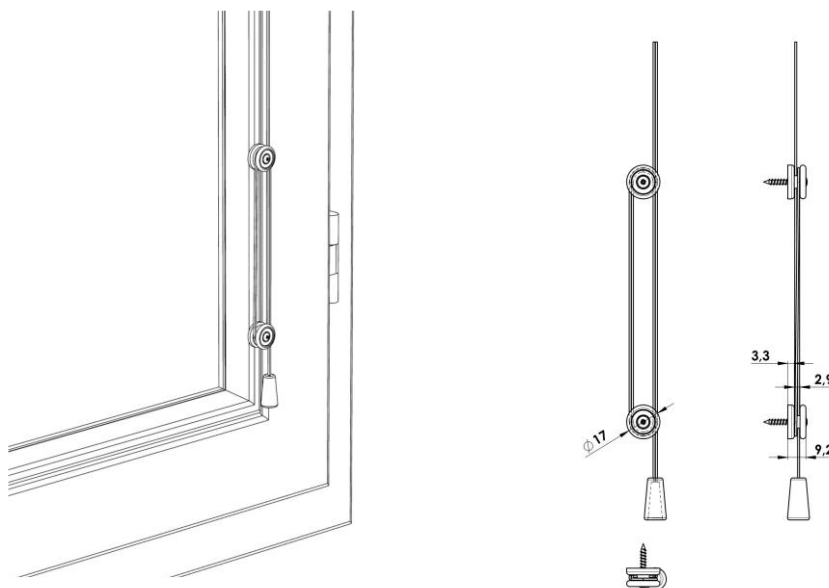
System 25R with brake + chain blinds with an area > than 2.5 m2

FOR CHAIN BLINDS WITH BRAKE, IT IS ALWAYS NECESSARY TO USE AN ENDLESS CORD HOLDER (so-called reel).

Illustrative use of the endless cord holder (so-called reel):

The holder must be used in case of:

- Chain blinds with brake (S25R, S25S)
- Chain blinds with an area > 2.5 m²
- Atypical chain blinds

The chain (cord) is threaded through the reel body. The remaining length of the chain must be wound around its arms so that the chain does not hang loose and form a dangerous loop - see fig.

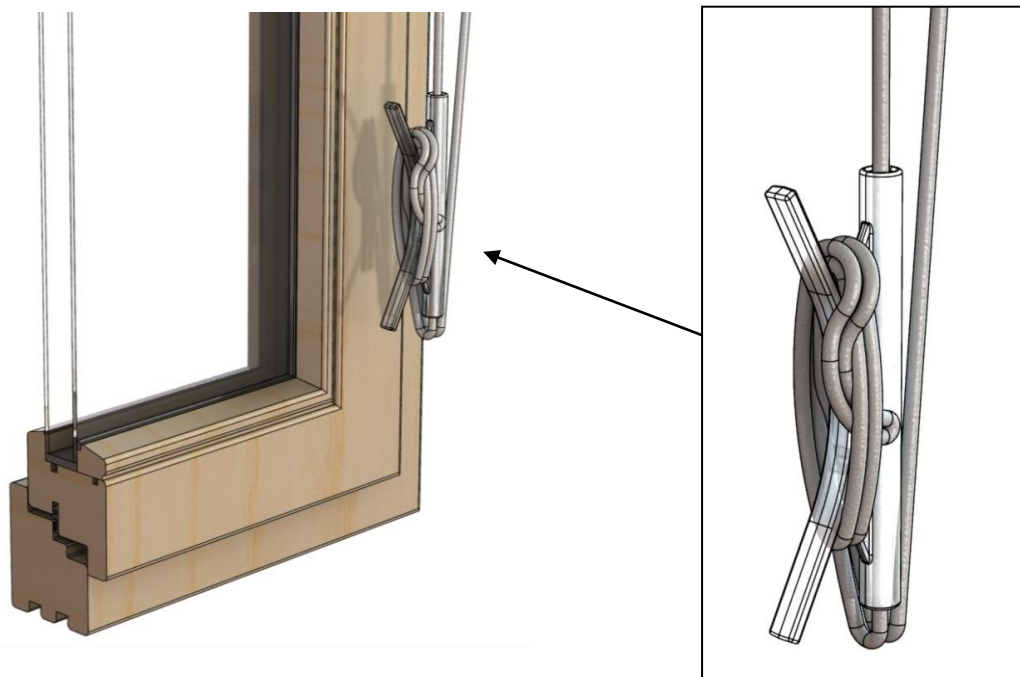

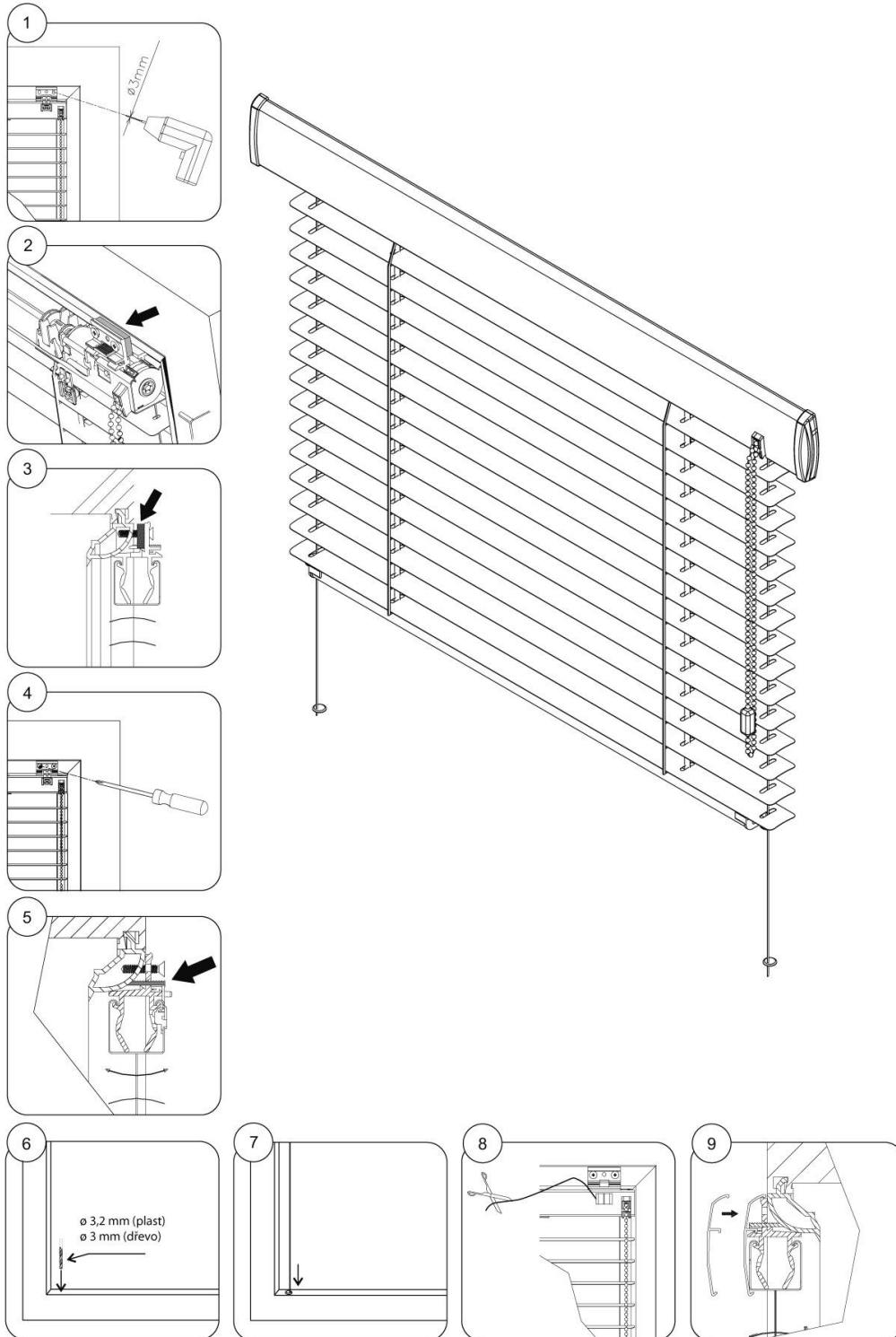
ILLUSTRATIVE ASSEMBLY OF THE BLIND WITH THE COVER PROFILE

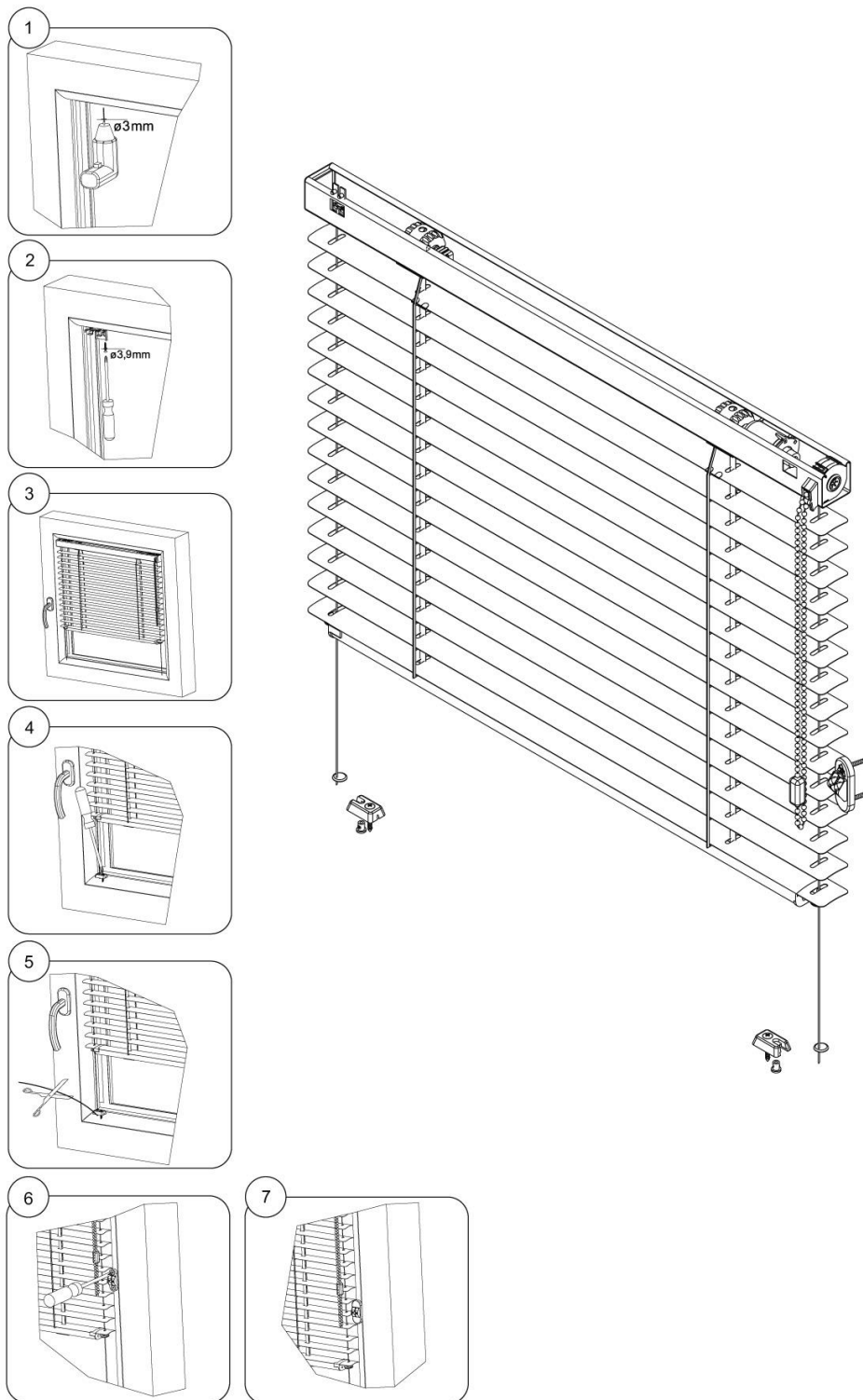
ILLUSTRATIVE ASSEMBLY OF THE BLIND WITHOUT THE COVER PROFILE

ASSEMBLY

Assembly without cover profile (construction - chain, cord, handle, engine)

- check the blind in the window wing so that the dimension corresponds to the width of the window; check that the control mechanism is on the right side. If it is necessary to be changed, it is not possible to change it for any System 25 blind. In this case, we recommend contacting the producer.
- place the blind to the window wing and screw each holder, using the two screws, into the glazing bar to prevent damage to the frame. For wooden windows the holes are pre-drilled to prevent cutting the glazing bar. Screw the solid transparent consoles into the lower part of the glazing bar. Draw the nylon or wire through the clamping screw and insert it into the solid console. Then, using your hand or pliers, tighten the nylon or the wire and tighten the worm in the clamping screw. Cut the excessive nylon or wire.

NOTE: If the shape or the size of the glazing bar does not allow drilling holes to secure the tightening pins into the glazing bar from upwards, choose the option of drilling the holes for pins into the face of the glazing bar. In this case, take care not to damage the glass with the drill. It is important to state the correct depth of the drilling! The client must be informed in advance of this form of assembly and consent in writing in the handing over protocol. Finally, ensure the full functionality of the blind and the window.

- secure the chain limiter, for plastic windows and wooden Euro windows secure it only into the glazing bar or mount the holder for fixation of the lever for the version with the lever.
- check the function of the blind

ATTENTION!

During assembly it is necessary to place the blind in the window which is not unpacked; mark the position of the screws on the window wing, fit the blind and then lower it. Each manipulation of the blind before assembly (if necessary) is only to be performed in the horizontal position Any other manipulation is forbidden and claims for such damaged blinds will not be accepted!