

The logo for ISOTRA, featuring the word "ISOTRA" in white uppercase letters on a red rectangular background. The letter "O" is replaced by a stylized globe icon with horizontal lines.

# SHADING FOR WINTER GARDENS AND PERGOLAS

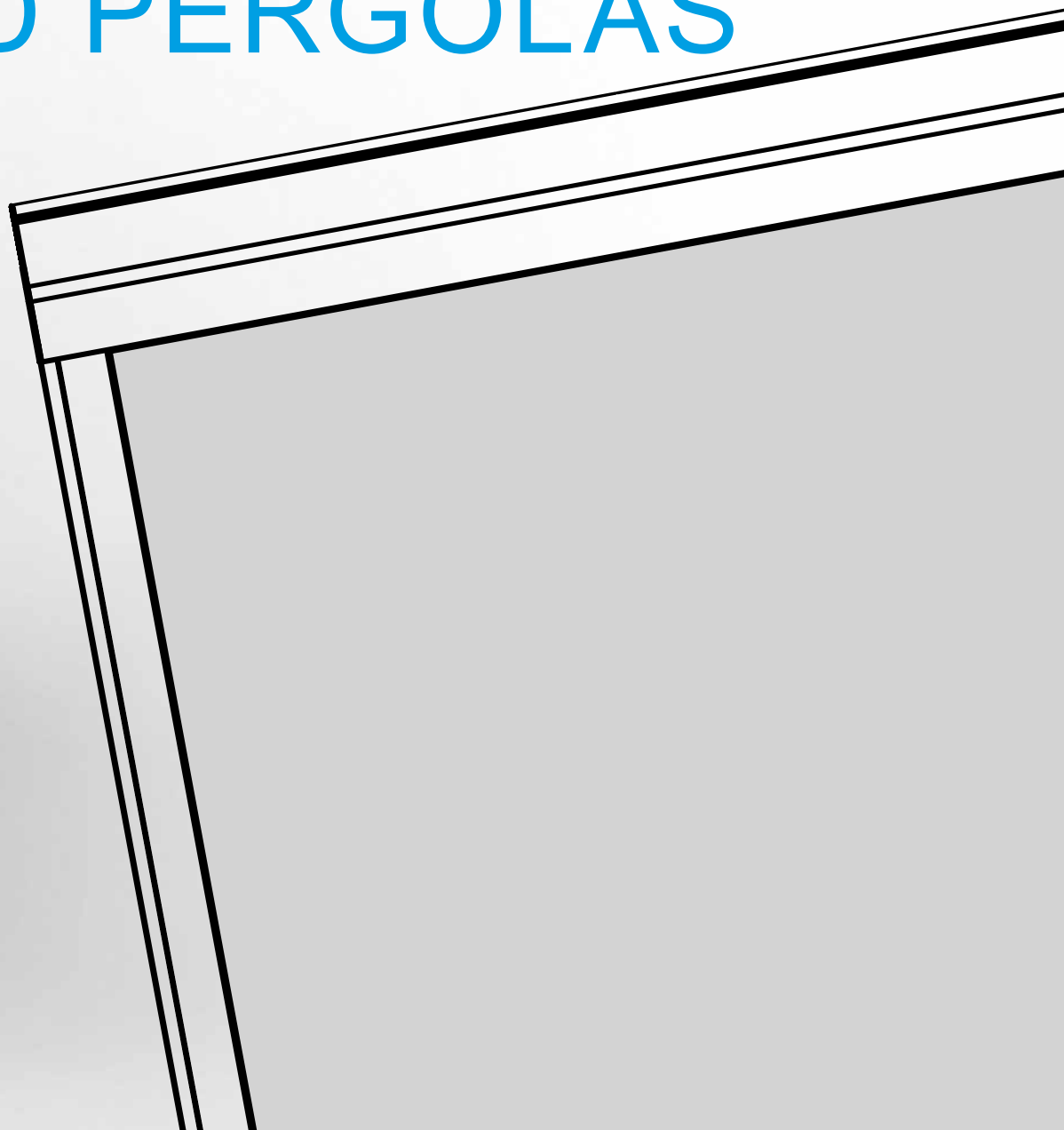

---

## Table of Contents - Shading for Winter Gardens and Pergolas

<b>VERANDA HRV52</b>	<b>3</b>
Basic Product Specification	4-12
Measurment and Assembly	13
<b>VERANDA HRV08-ZIP</b>	<b>33</b>
Basic Product Specification	34-43
Measurment and Assembly	44
<b>VERANDA HRV80-ZIP</b>	<b>55</b>
Basic Product Specification	56-66
Measurment and Assembly	67
<b>VERANDA HRV80-ZIP-2P</b>	<b>82</b>
Basic Product Specification	83-92
Measurment and Assembly	93
Instructions for replacing fabric	117

Products in this assortment group are always measured from the exterior.

---

## **ISOTRA** *Quality*

A mark symbolising long tradition, inestimable investment into development, the use of quality materials, state-of the-art technologies, reliable work from hundreds of employees and numerous other parameters, contrituting one entity - the final product of ISOTRA.

## Veranda HRV52

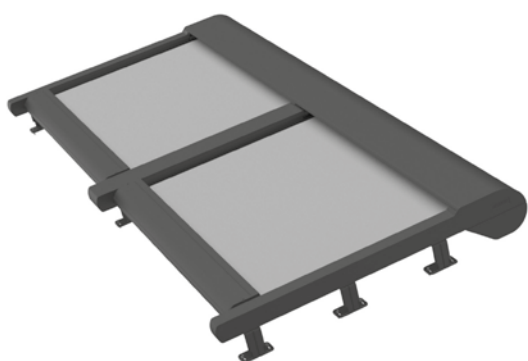

- ▲ Shading of large spaces of winter gardens
- ▲ Thermo regulation and protection effect
- ▲ Possibility to connect up to 4 pcs (do not have common box)
- ▲ Box is produced from extruded aluminum profiles

**ISOTRA** *Quality*

# VERANDA HRV52

## Basic Product Specification

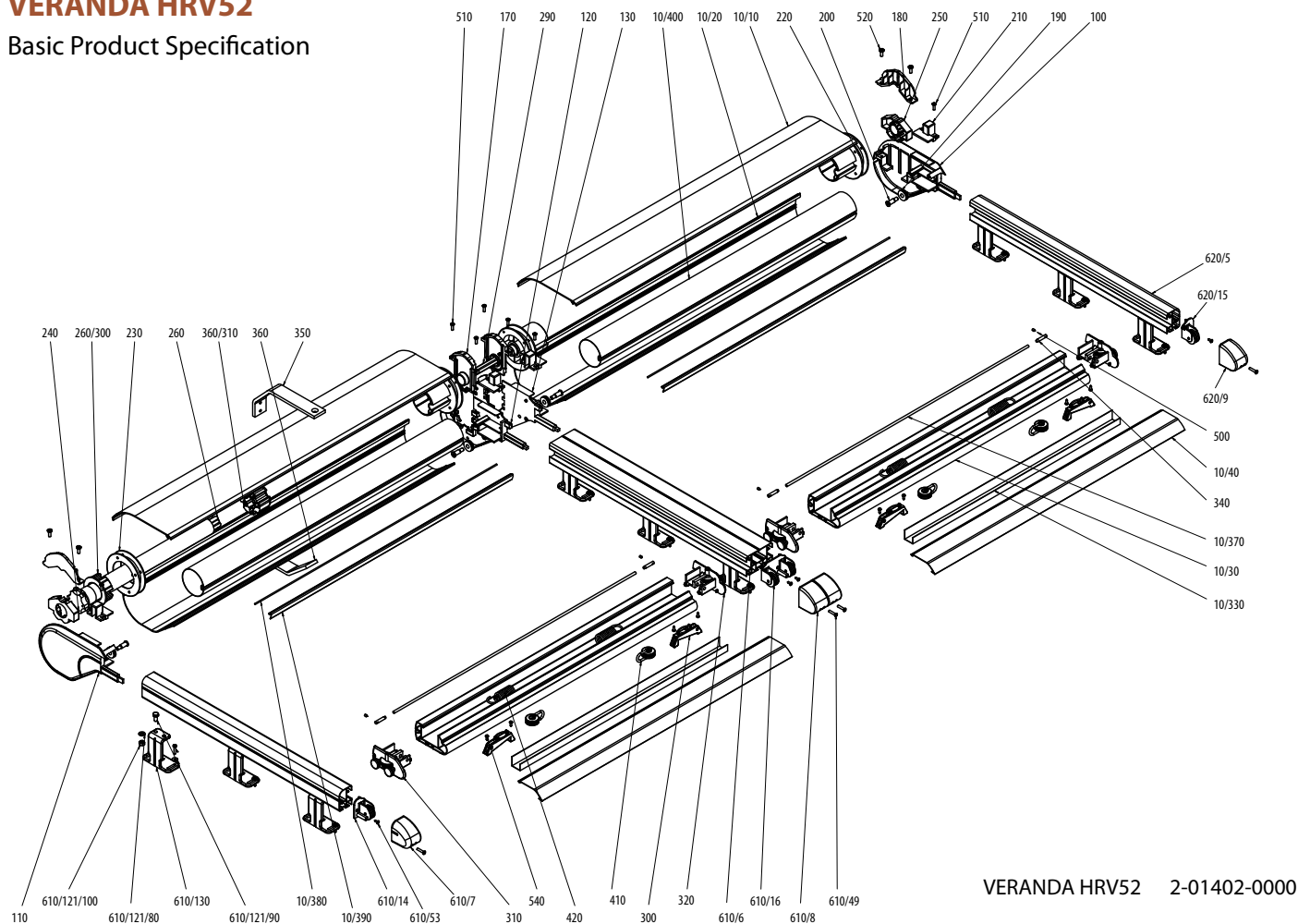

VERANDA HRV52 2-01402-0000

### Control

**Motor** – tubular motor 230V (50 Hz) with automatic post-regulation, this means the motor slows at approx. 10 cm before the bottom bar closes against the roller box so that it stops without forcibly hitting it. As standard there is supplied 3 meters long cable (optionally 5 or 10 m), a single-pole surface-mounted switch and plug.

### Fabrics

The fabrics are welded in vertical rows of about 885mm wide. The side straps have maximum width of 500mm, the side edges have constant width of 40mm.

### Specification

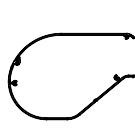
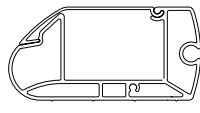
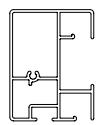
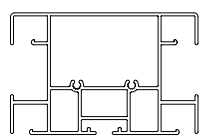
	Upper profile	Bottom profile	Suide guidance		Assembly
			Guide rail		
<b>Dimension (mm)</b>	145 x 215	56x115	61x46	61 x 94	above the winter garden
<b>Material</b>	Al	Al	Al	Al	
					
<b>Colour</b>	RAL 9010, RAL 9006, RAL 9007, RAL 8014, RAL 7016, RAL 7016S, DECORAL only up to 4000 mm width				

### Standard Dimensions

Control	Width (mm)		Height (mm)	Guaranteed area (m <sup>2</sup> )
	min	max	max	max
motor	1500	5500	6000	25

### Weight

The approaching weight = Width X 18 kg per meter (width)

## VERANDA HRV52 (2-01402)

position	item name	trade name - abbreviation 2	order number - abbreviation 1
<b>10</b>	<b>Profiles - VERANDA</b>		<b>see Profiles - VERANDA HRV52</b>
<b>19</b>	<b>Fabric for SCREEN</b>		<b>see screen fabric sampler – Soltis 92</b>
<b>20-25, 30-35</b>	<b>Fabric for VERANDAS</b>		<b>see awning fabric sampler</b>
<b>100</b>	<b>Side cap - RIGHT</b>	VRH 007/1	6-018120-0000
110	Side cap - LEFT	VRH 005/1	6-018119-0000
120	Side cap central - LEFT	VRH 008	6-014590-0000
<b>130</b>	<b>Side cap central - RIGHT</b>	<b>VRH 009</b>	<b>6-014591-0000</b>
170	Bearing - CENTRAL	VRH 051	6-014595-0000
180	Bearing cover for side frame - BLACK	VRH 042	6-014596-9004
190	Reverse wheel for side-cap - 28x8 mm	VRH 094	6-014597-0000
200	Peg for reverse wheel - 10x34 mm	VRH 014	6-014598-0000
210	Entrance part for side-cap - BLACK	VRH 137	6-014599-9004
220	Cylinder cover Ø 78mm	VRH 045	6-014600-0000
230	Cylinder cover for Motor Ø 78mm	VRH 047	6-014603-0000
240	Adaptor		
250	Bearing	VRH 052	6-014605-0000
260	Motors (Somfy) VERANDA		
290	Connection rod zinc coated	VRH 098	6-014606-0000
300	Terminal plate for HI - TEC cord	VRH 099	6-014607-0000
310	Bottom rail end-cap - LEFT BLACK	VRH 033	6-014608-9004
320	Bottom rail end-cap - RIGHT BLACK	VRH 034	6-014609-9004
340	Strengthening prop for box	MRH 144	6-014481-0000
350	Boxholder upperpiece	VRH 015	6-014611-0000
360	Boxholder lowerpart	VRH 016	6-014760-0000
410	Wheel with fork for cord guiding HRV		6-019123-0000
420	Spring 850 mm double spiral	VRH 092	6-014620-0000
500	Screw M5x8 DIN 914 (inbus)		
510	Screw M5x16 stainless A2, DIN 7985	VRH 106	6-014637-0000
520	Screw M6x16 stainless A2, DIN 7985	VRH 110	6-014638-0000
540	Woodscrew 4,2x13 DIN 7981 CH, A2	VRH 132	6-014640-0000
570	Woodscrew 4,8x16 DIN 7982, A2	VRH 135	6-014875-0000
590	Rivet Al 4x8 DIN 7337 A	SC 132 0000	6-003136-0000
591-594	Rivet Al 4x8	VRH 060-063	6-014932-XXXX
<b>610</b>	<b>Guidance - rail - LEFT</b>		<b>see Guidance - rail HRV52 - left/right</b>
<b>620</b>	<b>Guidance - rail - RIGHT</b>		<b>see Guidance - rail HRV52 - left/right</b>

## Profiles - VERANDA HRV52 (3-03076-PU11)

position	item name	trade name - abbreviation 2	order number - abbreviation 1
43383	BOX profile - cover	VRH 069	6-014580-0000
44105	BOX profile - bottom	VRH 071	6-014579-0000
11232	Bottom profile	VRH 073	6-014581-0000
14885	Bottom profile - cover	VRH 075	6-014582-0000
10/330	Profile PVC L=2m	VRH 084	6-014610-0000
10/370	Plastic bar PVC 6,0 mm	ZP0097/0006	6-016911-0006
10/380	Tube PVC dia. 3mm	VRH 113	6-014613-0000
10/390	Fabric clip profile - PVC - 6,0m	MRH 127	6-014566-0000
10/400	Roller Al dia. 78mm - 7m	VRH 123	6-014615-0000

## Guidance - rail HRV52 - left/right (2-01404-PU11L/P)

position	item name	trade name - abbreviation 2	order number - abbreviation 1
610/6	Guiding channel - double	VRH 087/1	6-018122-0000
610/7	Guiding channel end-cap - LEFT	VRH 036/1	6-018123-0000
610/8	Guiding channel end-cap - CENTRAL	VRH 040/1	6-018125-0000
610/14	Pulley LEFT	VRH 026	6-014592-0000
610/16	Pulley CENTRAL	VRH 028	6-014594-0000
610/49	Screw M5x25 DIN 966, A2	VRH 107	6-014635-0000
610/53	Woodscrew 4,2x13 DIN 7982, A2	VRH 133	6-014639-0000
610/121/80	Pad M8, DIN 125 A2	VRH 065	6-014632-0000
610/121/90	Screw M8x16, DIN 933, A2	VRH 112	6-014641-0000
610/121/100	Nut M8 DIN 934, A2	VRH 058	6-014642-0000
610/130	Holder standard	VRH 019	6-014630-0000
620/5	Guiding channel profile	VRH 090/1	6-018121-0000
620/9	Guiding channel end-cap - RIGHT	VRH 038/1	6-018124-0000
620/15	Pulley RIGHT	VRH 027	6-014593-0000

# VERANDA HRV52

## Technical Specification

### Upper profile (box)

Material : press formed from 1,2 mm thick pre-coated aluminium strip, and provided with a protective foil liner

Dimension : 145 mm x 215 mm

Consists of two sections :

- a removable chamfered upper section or cover
- a fix lower section

An extra reinforcement support is fitted in the middle of each section

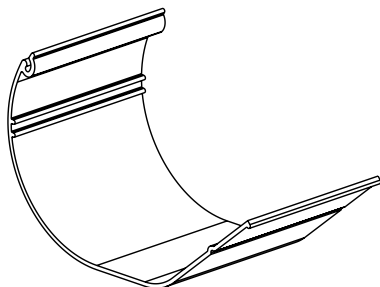
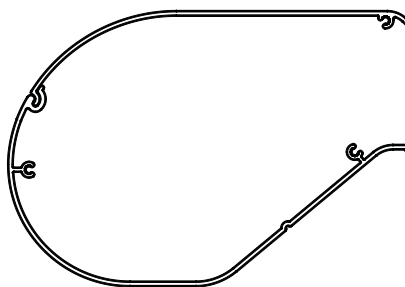

**Box - underside** (6-014579-0000)

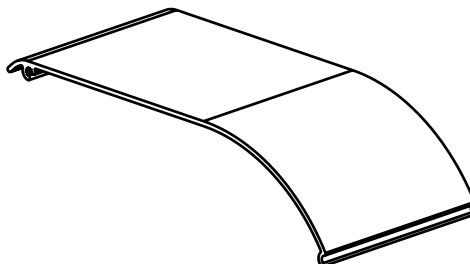

**Box - cover** (6-014580-0000)

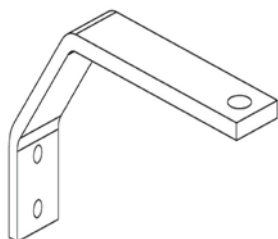

**BOX holder, upper part - VZ520** (6-014611-0000)

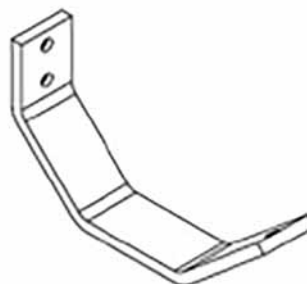

**Bracket BOX lower part VZ 520** (6-014760-0000)

The box holder is a part of the box stiffening bracket set (VRH 224, 2-01562-0000), which is recommended to be used from 4-meter box width of the Veranda HRV52.

### Bottom rail

Material : extruded aluminium, powdercoated

Function :

- The lower section : provided with 1 groove.
- The closing section : is clipped to the lower section

This profile runs along the slots in the side guides

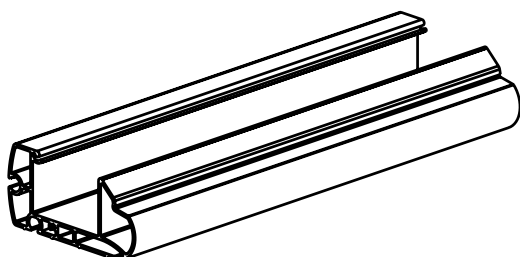
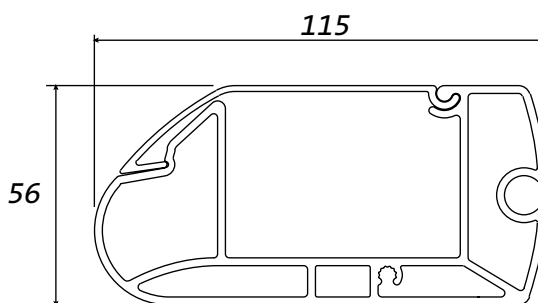

**Endprofil** (6-014581-0000)

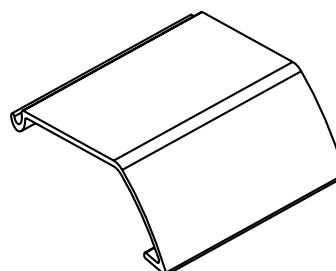

**Covering Endprofil** (6-014582)

**Fabric clip profile**

Material : consists of extruded PVC clips

Function : attaching the fabric in the fabric slot without the use of screws, so that the fabric can be removed from the front instead of sliding off sideways

Diameter of the PVC fabric retainer : 3 mm

Advantage : quick and easy fabric changing

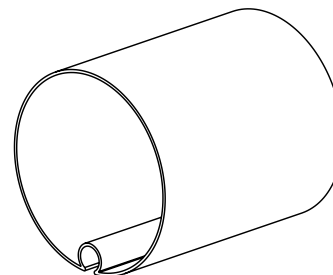
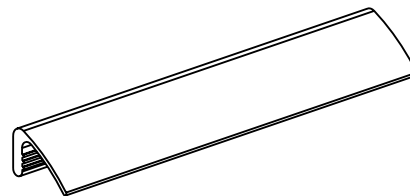

**Roller - aluminium, dia. 85 mm - 7 m**

Material : a welded tube, formed from a steel strip Sendzimir-galvanised, with a groove for attaching the fabric

- Function : rolling the blind fabric up and down.

- Diameters : Ø85x1,2 mm

**Intermediate roll for the inclined surface (2-01431-0000)**

Material : extruded aluminium tube Ø50 mm x 2 mm wall-thickness, powdercoated

Function : Used to support the fabric on longer projections

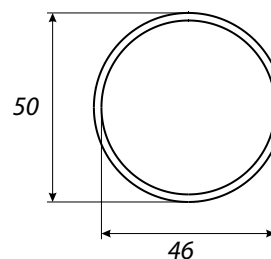
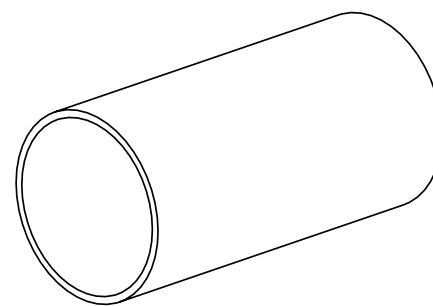

• Over 5001 mm extension :

Included as standard and installed in the middle of the projection

• Projection smaller than 5000 mm :

Intermediate roll in option

H/W	1500	1750	2000	2250	2500	2750	3000	3250	3500	3750	4000	4250	4500	4750	5000	5250	5500
1500																	
1750																	
2000																	
2250																	
2500																	
2750																	
3000																	
3250																	
3500																	
3750																	
4000																	
4250																	
4500																	
4750																	
5000																	
5250																	
5500																	
5750																	
6000																	

The intermediate roll is recommended.

The intermediate roll is included in the price.

## Guide rails

Material : extruded aluminium, powdercoated

Two types :

- End guides : installed on outer sides, with a front rail slot on one side only
- Centre guides : installed centrally, with a front rail slot on either side.

The profiles have a channel into which the bracket support pins fit.

Aluminium extrusions coated to match the frame.

End guides

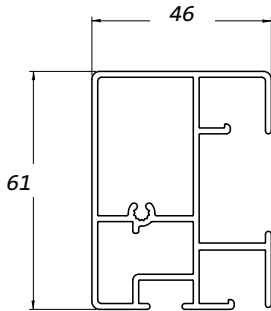

Centre guides

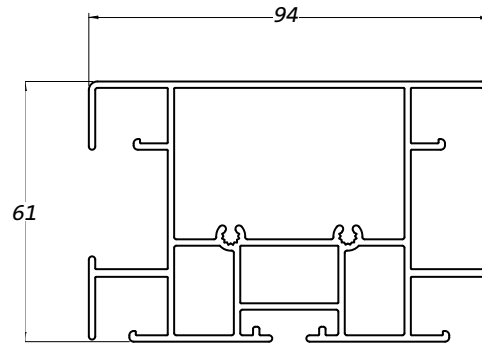

## The Consoles (or End Checks)

Material : hydraulic cast aluminium

- Colour : 9010, RAL 9006, RAL 9007, RAL 8014, RAL 7016, RAL 7016S, DECORAL only up to max. width 4000 mm

- Dimensions : 145x215 mm

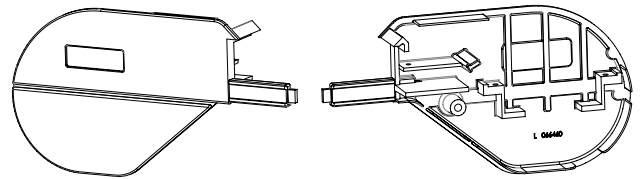

## Carriages

Material : cast PVC (Luran)

Colour : as standard black

Function :

- connection of front rail and side guides, fitted with two carriage wheels
- are mounted at the end of the front rail

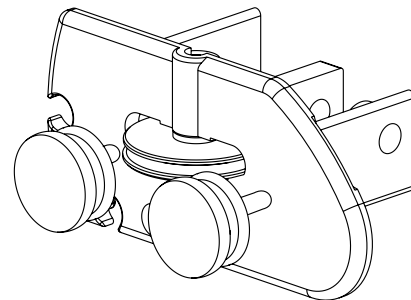

## The Tensioning System

Material : the castors, axles, etc. are made of non-corroding materials

Function : the entire fabric and front rail are kept under constant tension by means of a spring, a rope and a O2,5 mm cable

The constant spring tension ensures that the fabric remains taut in any position, to ensure adequate ventilation between the fabric and the glazing.

## Guide Fixing Brackets

### Standard support (6-014630-0000)

Material : aluminium

Colour : coated to match the frame

Function : used for any type of glass-covered conservatory framework and for all wooden pergolas and veranda systems.

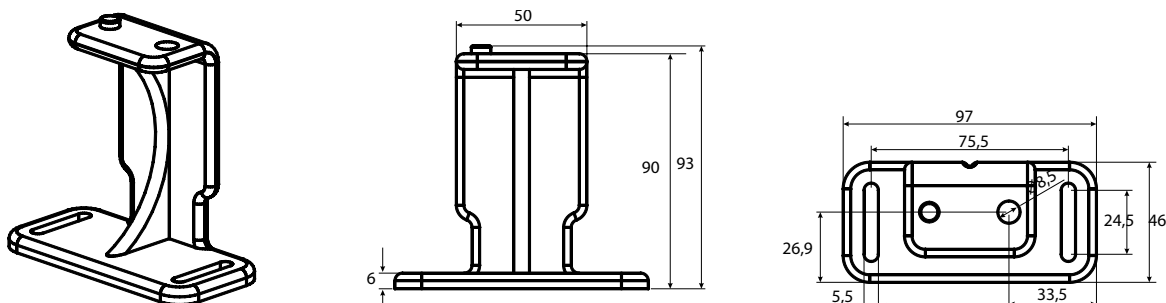

The clearance between the guides and the mullions can be increased by means of extension points (see guide fixing bracket Av, Bv and Cv).

Option: The supports are available in lengths of 120 mm, 200 mm, 300 mm or 400 mm

- Take into account that the verandaprofiles are under a higher load.
- They can only be used when there is no danger of them twisting.

The attachment system is in two parts :

- The upper part : Slides into the groove below the side and central guides
- The lower part, exists in two versions :

*Higher attachment point - low profile Av :*

- For any type of glass-covered aluminium conservatory framework and for all wooden pergolas and veranda systems.
- Is screwed on to the wood or into the groove at the top of the mullions through the capping section into which the rubber seal is fitted. (mounting A)

*Higher attachment point - high profile Bv :*

- For all types of conservatories with the glass beneath where the mullions have an extended leg above the glazing
- Is fixed to the mullion with two bolts. (mounting B)

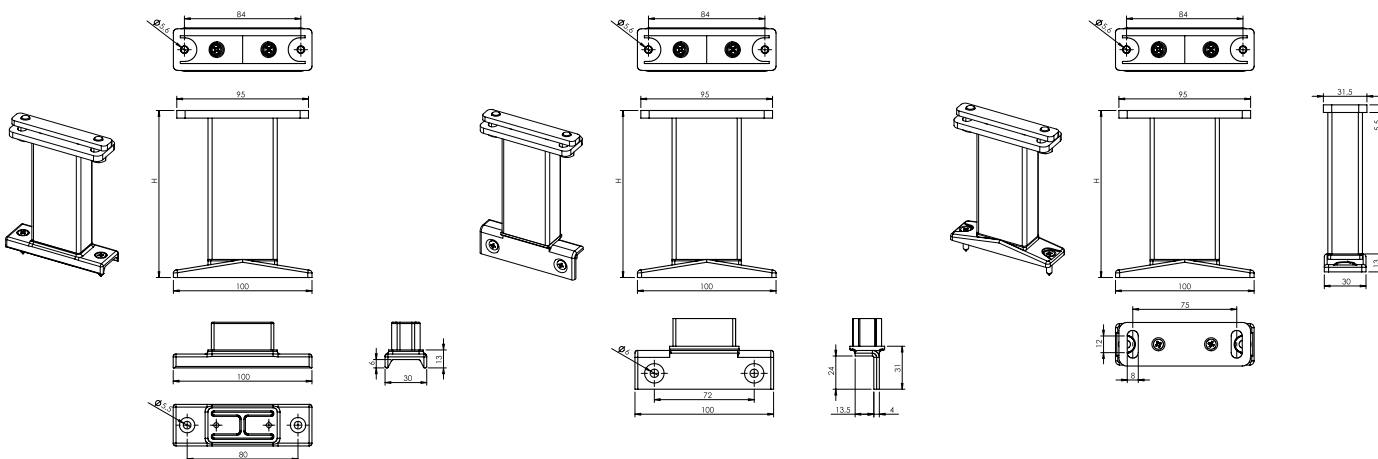

**Bracket VL Av** (2-01410-PU11X)

**Bracket VL Bv** (2-01411-PU11X)

**Bracket VL Cv** (2-01412-PU11X)

Intermediate roll for the inclined surface If a intermediate roll for the inclined surface is used in the HRV52 product (**height above 5m or customer requested by itself**), standard brackets can not be used, but guide fixing brackets **Av, Bv, Cv** can only be used.

## Brackets for intermediate roll

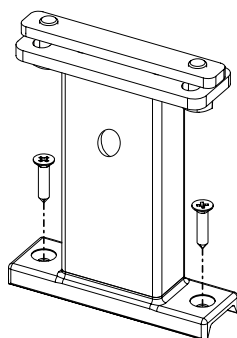

Bracket Av

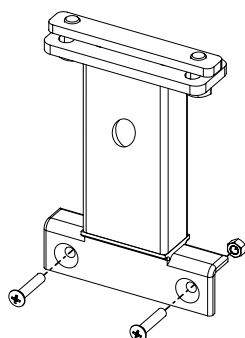

Bracket Bv

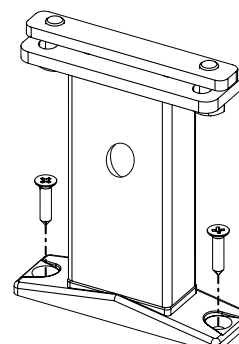

Bracket Cv

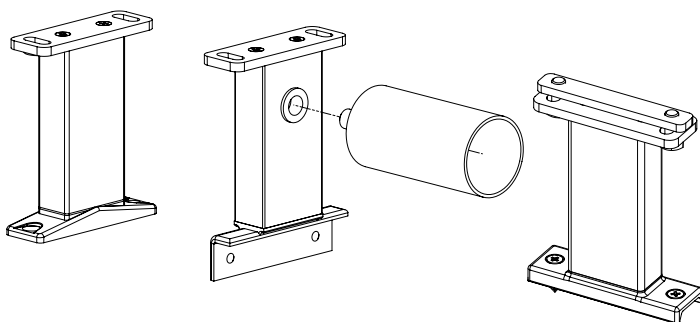

### Additional fixing possibilities :

- If fixing methods A or B are not possible, an option is to fix against a wall. For this, angled profiles can be used in combination with flat attachment points C
- The upper- and lower part fixings are slotted to allow for any minor seating tolerances in the roof sections
- The maximum distance between two fixing points along a guide is max. 1600 mm

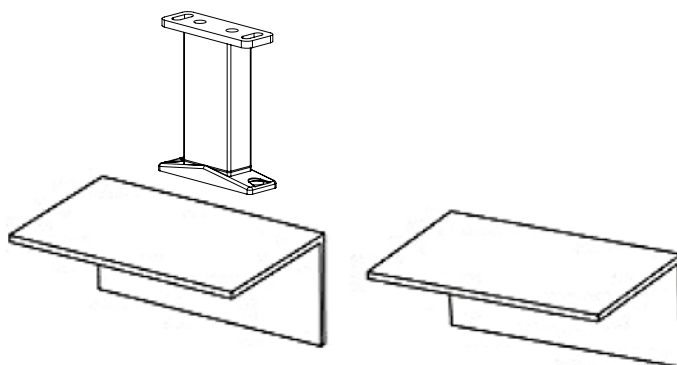

Remark : In case of an intermediate roll, the awning will be mounted on higher aluminium attachment points of 120 mm.

### Standard guide fixing bracket SA

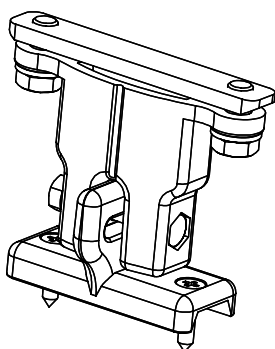

### Standard guide fixing bracket SB

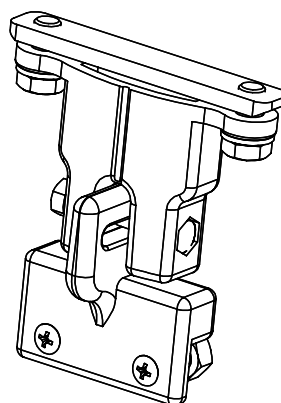

### Fixing on the wall

Additional fitting options:  
If fixing methods A or B are not possible, an option is to fix against a wall. There are 3 standardised L-profiles. (Always to be used with flat supports Cv).

Available in the following sizes:

- Type L1 = 50 x 30 x 3 mm
- Type L2 = 100 x 50 x 3 mm
- Type L3 = 130 x 50 x 5 mm

For extension length up to 3 m, only 1 profile is used. For extension length over 3 m, 2 profile pieces are used.

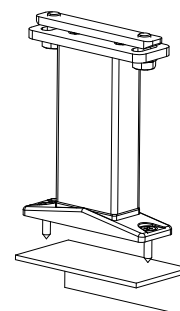

**Technical options – verandas coupling**

Type	Maximum width (m)								Max. area	Number of verandas	Number of motors
	1,5	3	4,5	5,5	6	11	16,5	22			
Type 1	1 veranda								25 m <sup>2</sup>	1	1
Type 2	2 verandas								50 m <sup>2</sup>	2	1*
Type 3	3 verandas								75 m <sup>2</sup>	3	2
Type 4	4 verandas								100 m <sup>2</sup>	4	2

(\* )also optional with 2 motors

**Coupling Two Side Guides**

To connect 2 veranda sunblinds, coupling parts are available.

Coupling set

It consists of coupling plate, angle coupling and the attachment.

Function:

- When the standard attachment point is placed in the middle, the upper part should be replaced by the angle coupling
- When the standard attachment point is placed left or right on the guide, the coupling will be done independently of the attachment point, by mounting the coupling plate behind the attachment points
- When the extended attachment point is placed in the middle, the upper part should be replaced by the coupling plate

Coupling set

- we always deliver as a complete set (coupling plate + angle coupling), automatically painted in the construction colour.

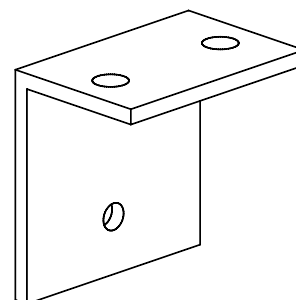
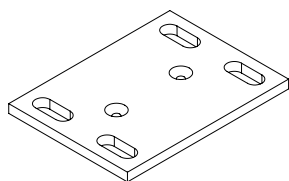
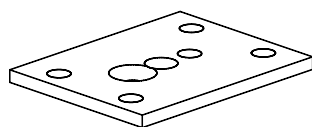

Coupling plate

Angle coupling 6-014820-0000

If the Verandas are coupled, the guide is always double. If there are two simple Verandas next to each other, the connection of simple guide rails is possible only through the connection system.

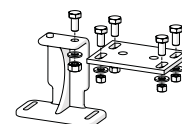
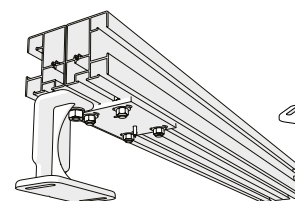
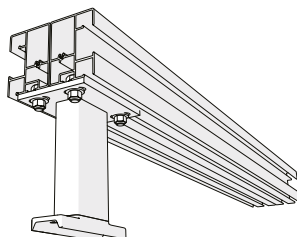
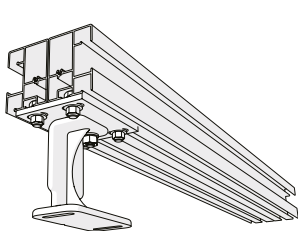

## Control

Drive via tubular motors 230 Volt (50Hz)

- Fitted with automatic post-regulation, this means the motor slows at approx. 10 cm before the bottom bar closes against the roller box so that it stops without forcibly hitting it
- Fitted far left and/or far right as required
- Control location when viewed from the outside.

Cable :

- As standard 3 m
- Optionally 5 or 10 m
- The distance can be increased by fitting a junction box

A single-pole surface-mounted switch and plug are supplied as standard.

## Motor control

Types of motors

### VERANDA HRV52

item name	trade name - abbreviation 2	order number - abbreviation 1
Motor OREA 50 WT 40/17	MR 096/40	6-001550-0040
Motor OREA 60 WT 55/17	MR 096/55	6-001550-0055
Motor OREA 60 WT 70/17	MR 096/70	6-001550-0070
Motor OREA 60 WT 85/17	MR 096/85	6-001550-0085
Motor OREA 50 RTS 40/17	MR 092/40	6-011171-0040
Motor OREA 60 RTS 55/17	MR 092/55	6-011171-0055
Motor OREA 60 RTS 70/17	MR 092/70	6-011171-0070
Motor OREA 60 RTS 85/17	MR 092/85	6-011171-0085
Motor Sunea 50 io 40/17	MR 134/40	6-012559-4017
Motor Sunea 60 io 55/17	MR 134/55	6-012559-5517
Motor Sunea 60 io 70/17	MR 134/70	6-012559-7017
Motor Sunea 60 io 85/17	MR 134/85	6-012559-8517
Brush 6,7x1500 EC (height 15 mm)	SC 250/15	6-001314-1500
Brush 6,7x1800 EC (height 18 mm)	SC 250/18	6-001314-1800

### Types of motors (BECKER) for Veranda HRV52

item name	trade name - abbreviation 2	order number - abbreviation 1
Motor BECKER 50 E 40/17	17BE	6-017852-0040
Motor BECKER 50 E 40/17	BE40	6-017852-0040
Motor BECKER 60 E 60/17	BE60	6-017852-0060
Motor BECKER 60 E 70/17	BE70	6-017852-0070
Motor BECKER 60 E 120/11	BE120	6-017852-0120
Motor BECKER 60 C 60/17	16BC	6-017853-0040
Motor BECKER 60 C 60/17	BC40	6-017853-0040
Motor BECKER 60 C 60/17	BC60	6-017853-0060
Motor BECKER 60 C 70/17	BC70	6-017853-0070
Motor BECKER 60 C 120/11 PLUS	BC120	6-018886-0120

Note: E=electronic motor, C=radio motor

## VERANDA HRV52

### Measurement and Assembly

#### Measurement

The total width = centre of side guide to centre of side guide. The outside of the box is always 40mm (2x20mm) larger than the middle of the guide rail or the middle of the attachment points.

The projection : measured from the back of the roller box at the top against the wall to the front of the guide, included the cover.

Attention : the extension pole always stops before the covering cap, this means at minimum 63mm of the end of the guide rail.

Note : the width of the roller box is always 40 mm more than the over-all width of the blind.

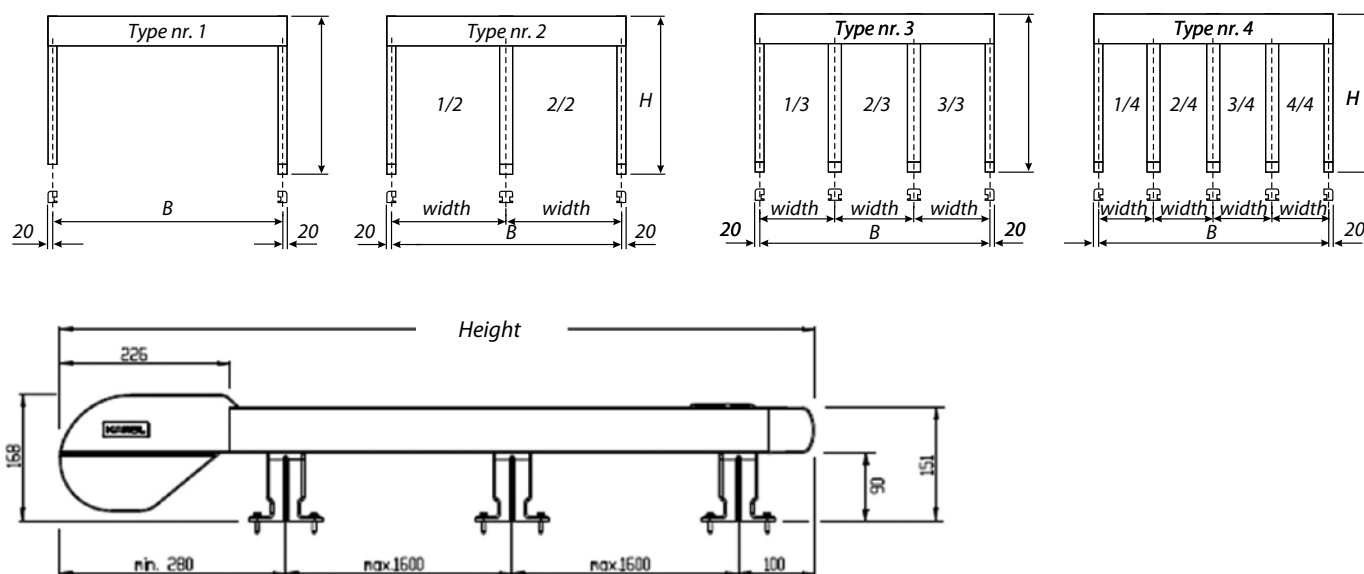

#### Assembly

##### 1. Open the packaging

Take the bag of accessories, and divide the attachment points by the number of guide rails supplied. Make sure each guide rail has the same number of supports. Assemble the support on the guide rails.

##### 2. Setting up the ladders and footplanks on the Veranda

##### 3. Unpack the boxes

Take the boxes out of the packaging and lay them out in the right order on the roof of the Veranda.

##### 4. Checking the measurements

Check the dimensions of the awning against the Veranda profiles. Small deviations in measurements will be caught up by the movable supports.

##### 5. Outlining the different positions

Using a completely prepared guide rail, mark on the roof where the supports are to be mounted. Take care: the distance between the top support and the top end should be ca. 280 mm. Drill holes, for the base pieces of the supports, and screw the supports tightly onto the Veranda frame.

##### 6. Positioning the wooden blocks

Take a few blocks (60x60x300 mm) and slide them under the mounting brackets between the boxes and the Veranda profile.

##### 7. Removing the protective plastic foil from the boxes

##### 8. Connecting the boxes

Take care that the spindles are matched to each other correctly. The slots for the fabrics must be in line with each other. (avoid getting dirty spots on the fabric). Insert the square connecting shaft one side halfway into the side-hole. Check that the blind slot matches, then insert the other half in the other hole. Now press the two halves of the mounting bracket together and fix them by using the screws supplied. Now screw the yellow slides against each other using the small bolt and nut supplied. Each slide has a hole at the top for this purpose. Only connect up in the right place.

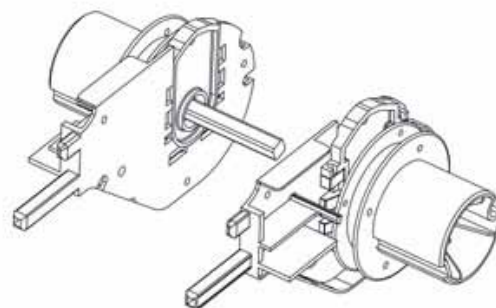

**Attention:** Only couple the spindles as allowed. Given that the power of the motor is selected according to the number of blinds to be operated, the number of blinds connected up must match the number allowed for the motor.

For this reason, end brackets not supplied with a connector are covered by a self-adhesive patch.

### 9. Positioning the awning:

Slide the entire sun blind assembly over the wooden blocks upto the right position. (Which may be hard against the wall). Take care that the Veranda profiles are at right angles regarding to the wall. We are working with a squared-off system.

### 10. Unwinding the cables

Unwind the cable so that there are no loops or kinks. Check that at least 2 or 3 turns of cable are left on the cable pulley. Mind that the cable unrolls along the bottom side.

Connect the motor cable up provisionally using a test cable and let the endprofile run out for +/- 15cm.

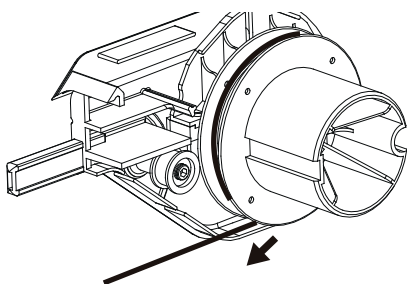

### 11. Positioning the cables into the guide rails

Take a guide rail, and insert the cable across the entry pulley. Hold the rail pointing diagonally downwards and push the cable through the rail. Make sure that the cable comes out again through the right hole. At the far end, feed the cable back round the pulley.

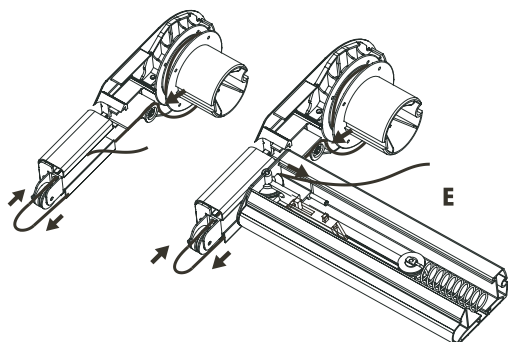

### 12. Positioning the box and the guide rails

Now lay the guide rails onto the glass roof, just in front of the pins of the mounting brackets. Make sure that the pins of the mounting brackets on the box are in line with the guide rails.

### 13. Positioning the cables into the endprofile

Insert the cable into the endprofile, aside via the small hole behind the pulley on the slider block.

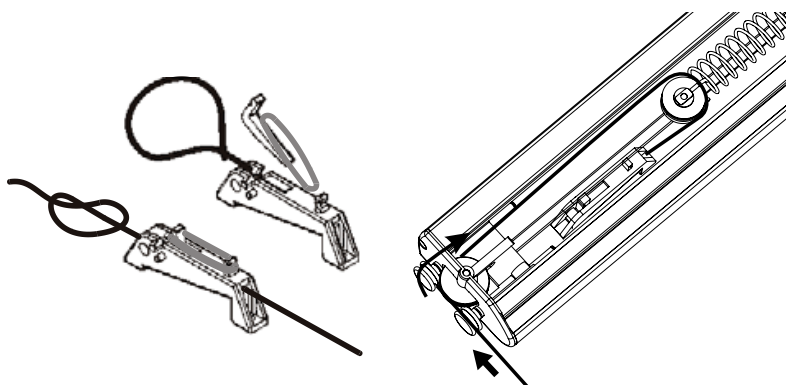

#### **14. Positioning the cables**

Lift the box and the end profile to the same height as the guide rails, and insert the endprofile a short way into the rail.

Insert the pin of the mounting bracket into the aperture of the guide rail.

Make sure that the cord and the carriage fit snugly

Then pull the cable at point E and the pin will automatically slide into the guide rail.

Do the same for all the guide rails.

#### **15. Fixing the Veranda in the supports**

Position the Veranda in the supports, and screw the supports hand-tight by using the screws supplied. Remove the wooden blocks.

#### **16. Placement of the intermediate rolls**

In case of using intermediate rolls, by extremely large extension, the brackets are placed just underneath the guides. The intermediate rolls must be placed in line to each other and rather in the middle of the lateral guide.

#### **17. Tensioning the spring**

Position the endprofile in the highest position and make 2 marks in the endprofile the distance apart R shown in the separate table.

The maximum distance depends on the spring supplied, the used fabric, the diameter of the roll for fabric and the extension of the blind.

Make sure the marks are always at the same distance from the centre of the endprofile.

Feed the cable round the pulley (through the fork) and insert the cable through the hole in the rightangled bracket on the end of the endprofile. Feed the cable back through the second hole and tighten the cable clamps on the cable behind the right-angled bracket so that the axle of the pulley is against the marks in the endprofile. (See fig.)

Check carefully the feed of the cable over all the pulleys both on the front of the guide rail, as well as at the endprofile slider block and the cable feed pulley.

Pay attention to the symmetry of the spring.

#### **18. Inserting the spring**

The Veranda is still in its highest position. Check that the cable doesn't cross over at the cable pulley, but running cleanly side by side. Thread the spring into the forks of the pulleys and insert the cable into the cable unit. Make a knot in each cable, behind the clamp unit. The Veranda is now under tension.

If the motor is an Orea or an Altus RTS, please consult the enclosure of the concerned motor

#### **19. Running the motor to its stopping point**

Let the motor run until it switches off.

Check that the motor stops where it should, not touching the end pulley on the guide rail. The motor is not adjusted.

Set the end positions according to the instructions and motor type.

## 20. Controle of the right angles

Set the veranda to bottom position. Screw down the base supports permanently. The guide rails and the box should stand at right angles to each other. You can check this by using a large try square or the 60-80-100 rule as shown in figure. A better, and much more precise, way is to measure the diagonals of the separate sections and of the entire construction. The difference between these diagonals must not be more than 2 mm. Also make sure that the guide rails run perfectly parallel along their entire length, so that the tension between the extension profile and the guide rails remains constant.

## 21. Adjusting the highest position

Roll up the sun blind, and stop it by using the fixed switch at ca 10 à 15 cm. before the blind closes. Check up that the endprofile runs straight. Then push the blue button so that also this one lifts up. Let the motor run a little downwards ( 10 à 15 cm). Then let the sun blind close completely. The motor will hum for another few seconds and finally it will stop. (To catch up possible future elasticity of the fabric). The final switches for the motors are adjusted that way.

Should it be necessary to readjust the motor, then you can push down again both the buttons. The settings are then erased and you can recommence the adjustments beginning at point 18.

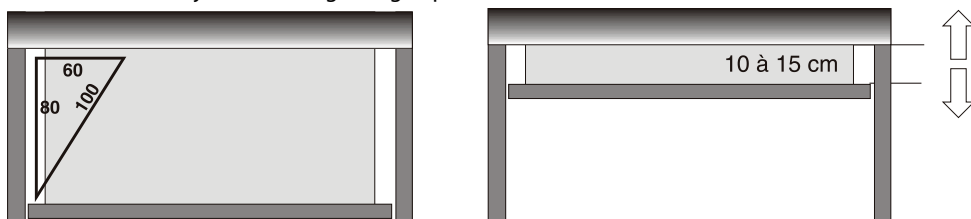

## 22. Secure the Veranda

Screw the socket-head screws on the square clamps for the lowest supports tightly. The entire system is now prevented from sliding downwards.

## 23. Positioning the plastic U-profile

Position the plastic U-section underneath the spring inside the endprofile, so that the spring can move silently in the endprofile. Close the box, and the endprofile. Mount the aluminum covers on to the end of the guide rails.

## 24. Connection and installation of the motor

Take the electric cable from the motor inside and connect the single-pole switch. If necessary, reverse the brown and black leads following the signs on the switch.

For the installation of type 3 and 4 we proceed the same way, except in this case we have to use a relay box if we will be running more than one motor from a single switch. For the connections, see flow chart R12. The installation of the Veranda has to be done according to the rules.

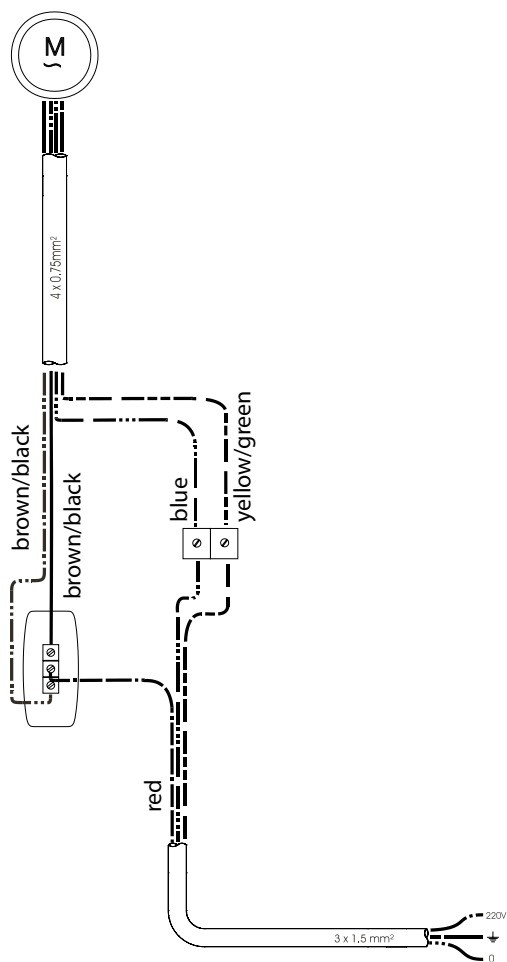

## 25. Electrical connections

There are 4 wires from the motor. Yellow-green (earth), blue (neutral), brown and black (raise and lower)

From the fuse box, there are 3 wires. Yellow-green (earth), blue (neutral), and phase. Connect the wires as shown in the diagram. The phase wire from the fuse box should be connected to terminal L. If necessary, reverse the brown and black leads from the motor in the switch so that the arrows on the switch correspond to rolling up and unrolling the Veranda.

The 2 earth wires are connected using separate clamps. Do the same for the 2 neutral wires.

### Method for coupling 2 guide rails

In some cases we have to couple 2 guide rails (when 2 or more systems are mounted beside one another. This can be done in different ways.

#### Mounting the base attachment point in the middle

The coupling plate is fixed directly underneath both guide rails. The standard attachment point is fixed on the coupling plate.

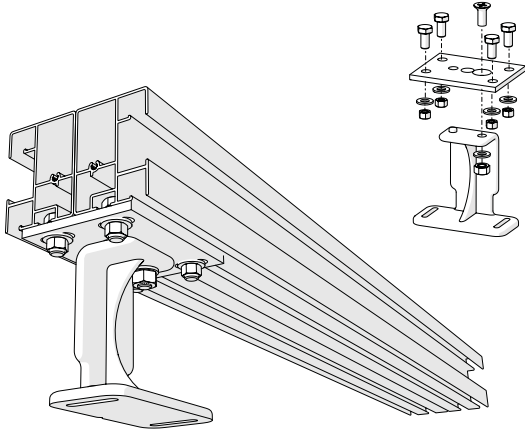

#### Mounting the attachment point high profile in the middle

The upper part of the high profile attachment point is replaced by the coupling plate. The coupling plate is fixed underneath both guide rails.

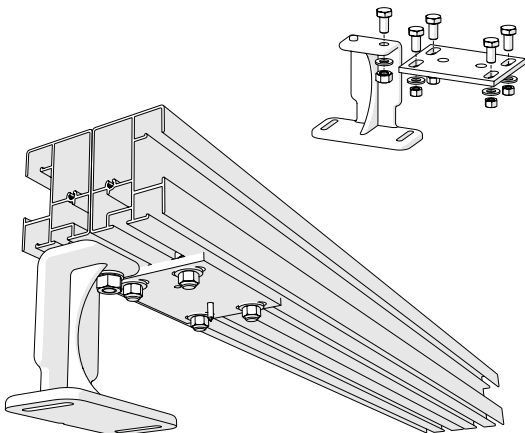

#### Mounting the attachment point underneath the left or the right guide rail

The coupling plate is fixed in front of or behind the used attachment point.

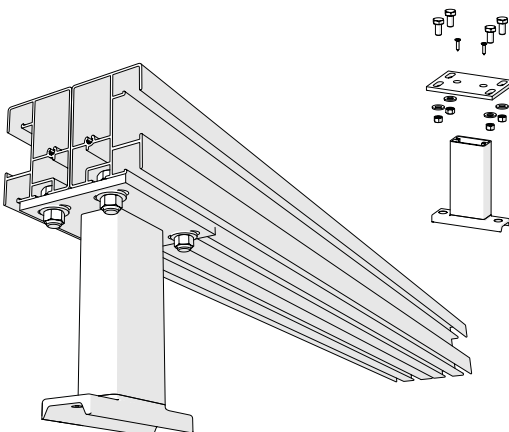

1

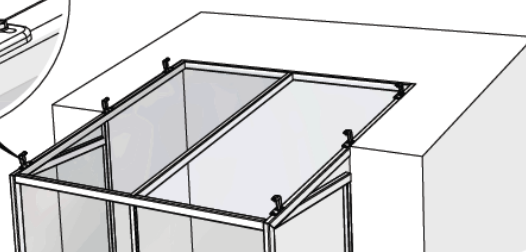
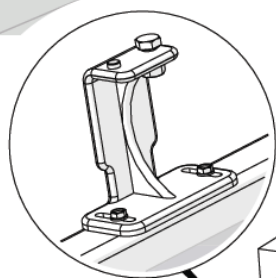
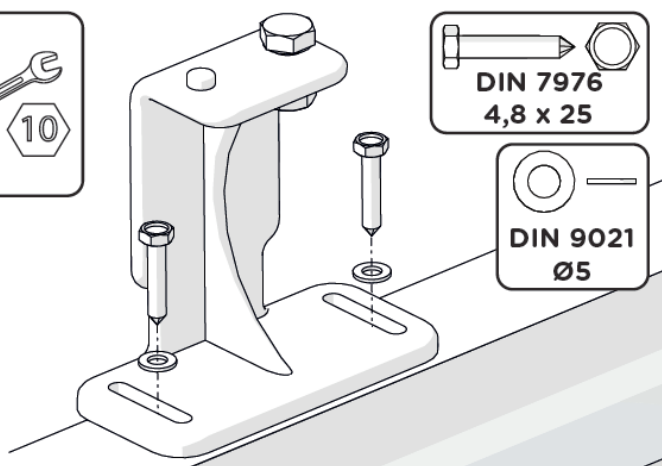
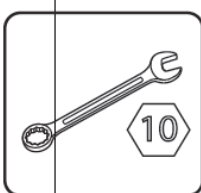
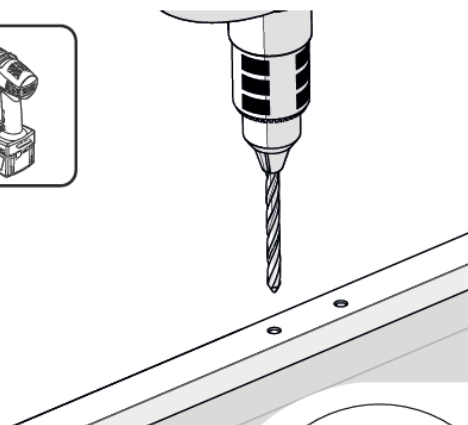
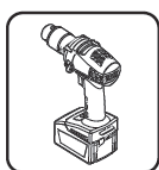
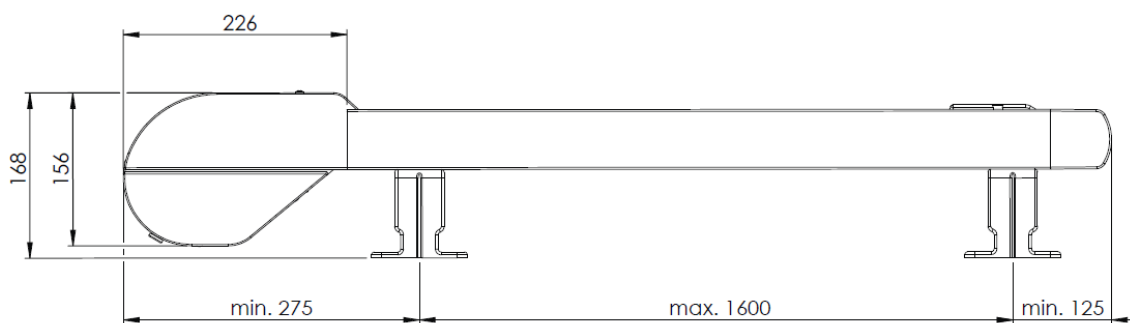
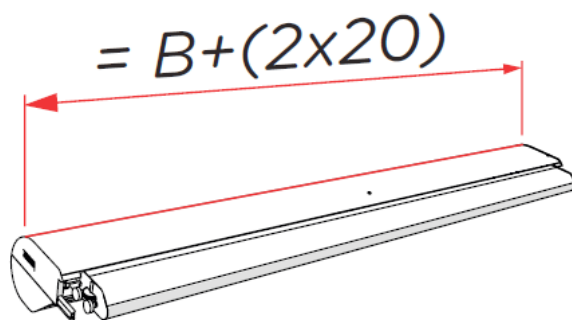
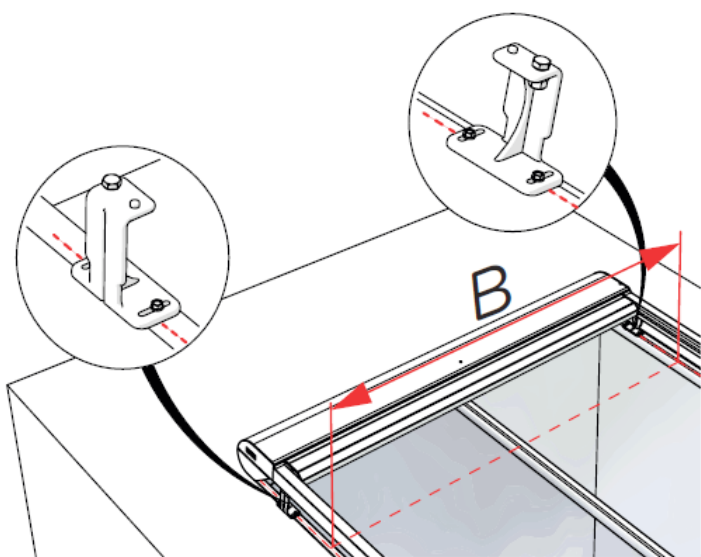
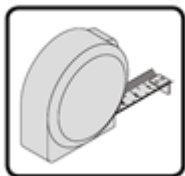

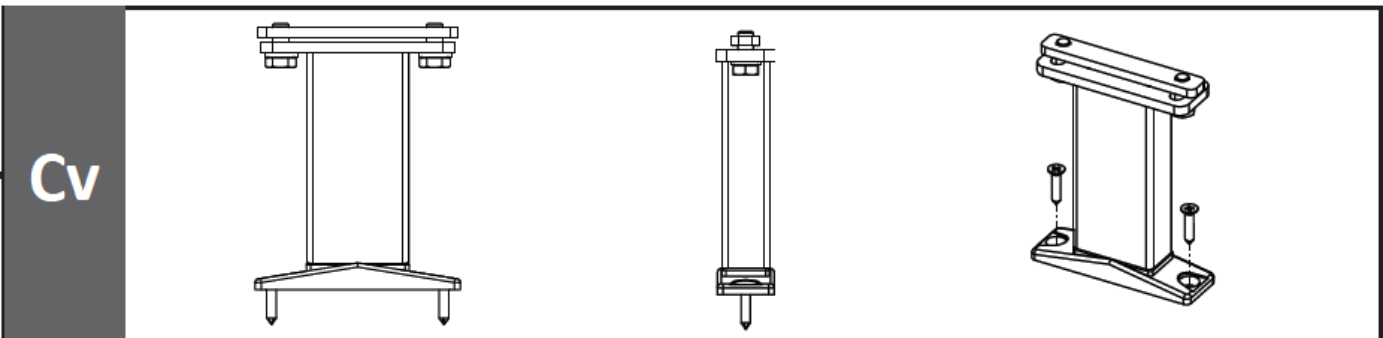
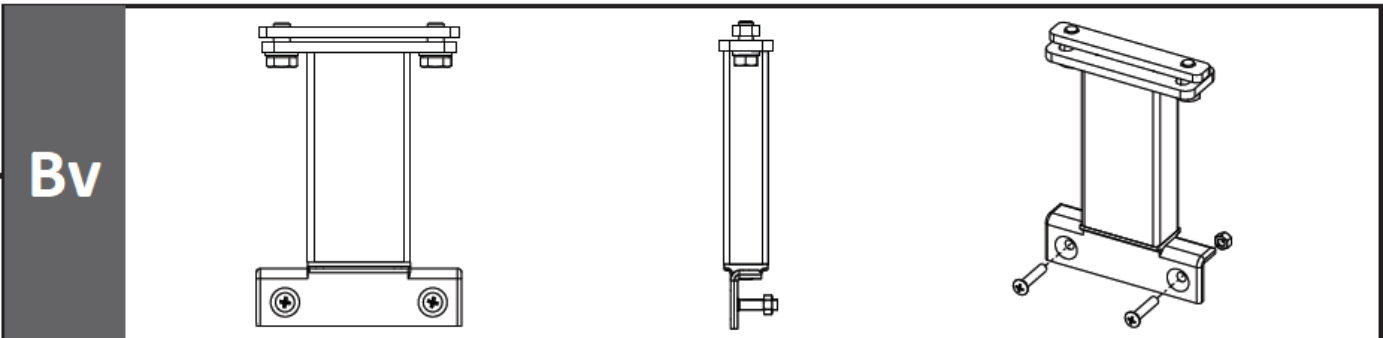
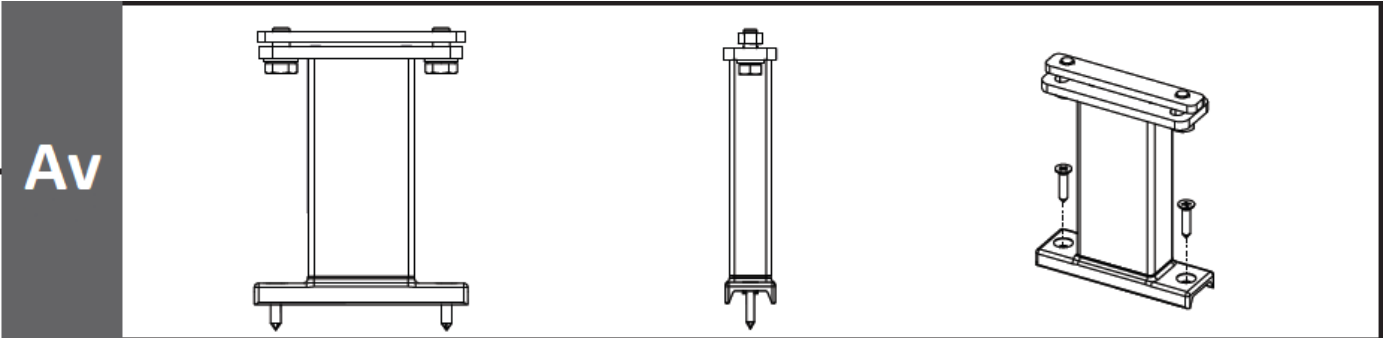
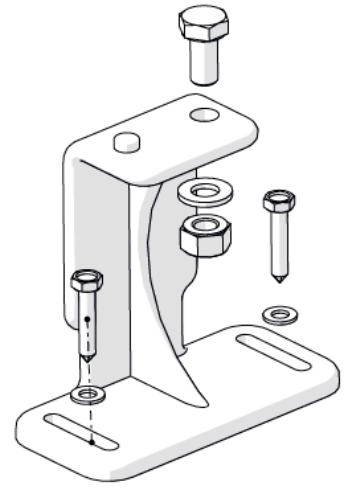
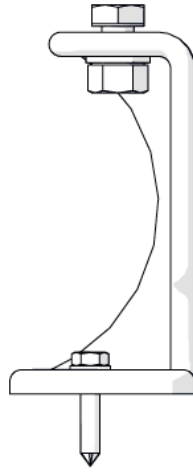
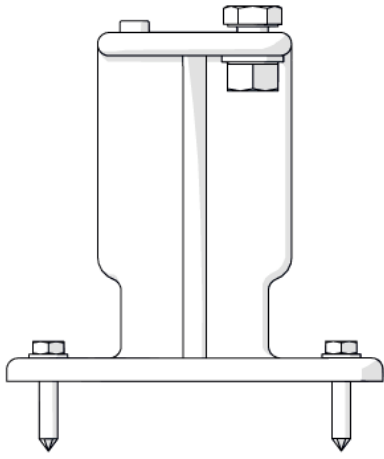

2

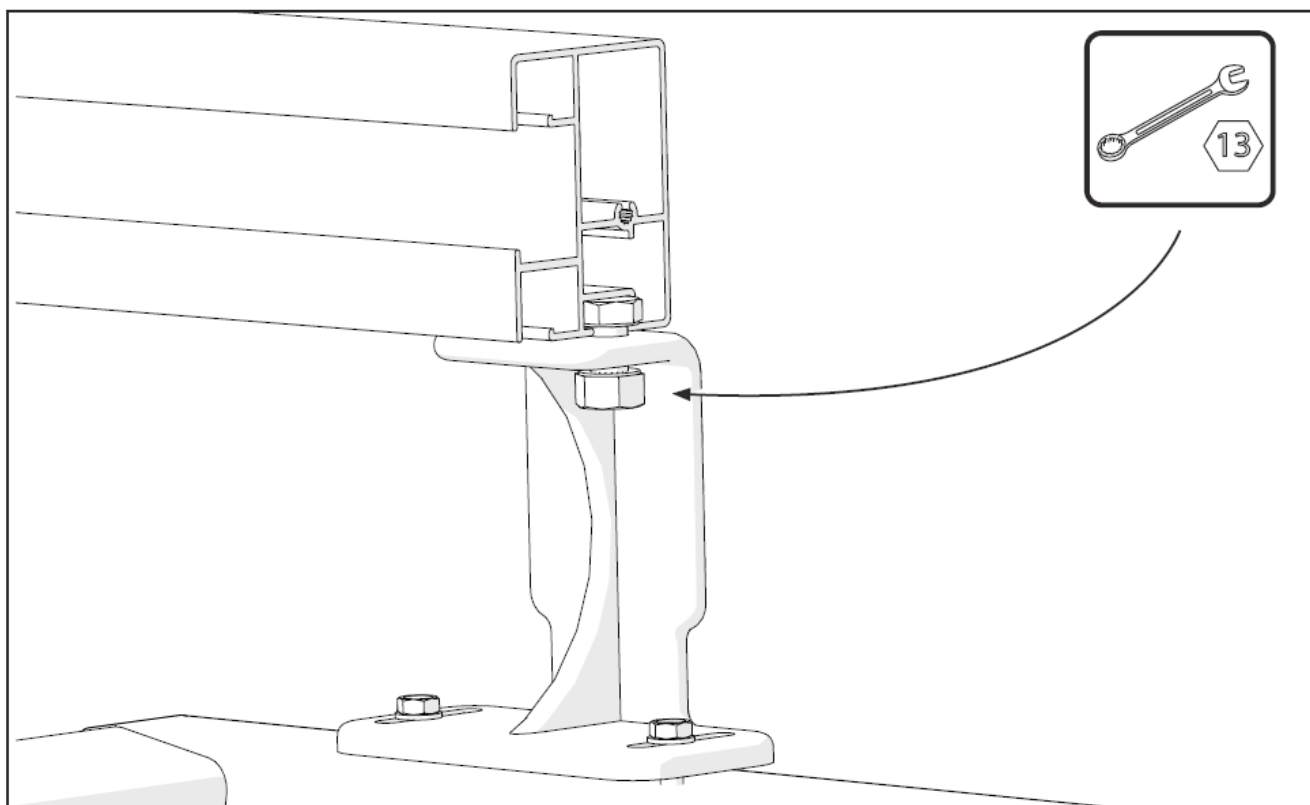
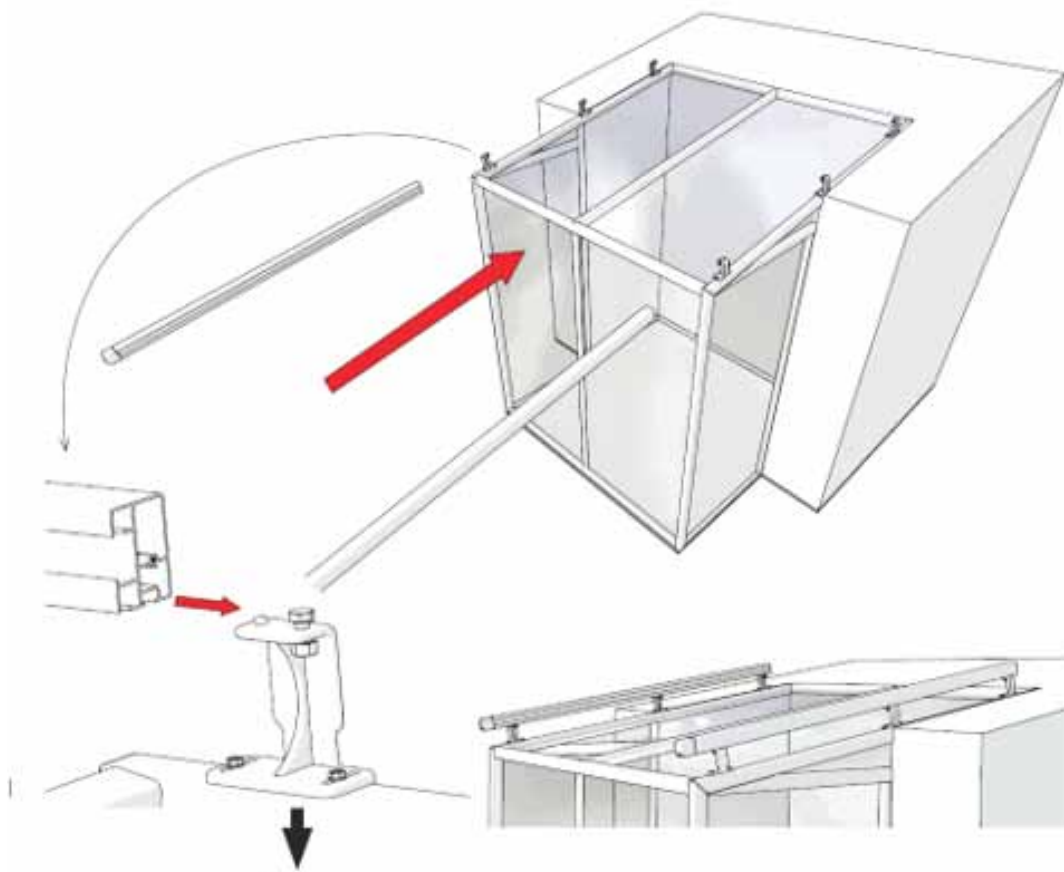

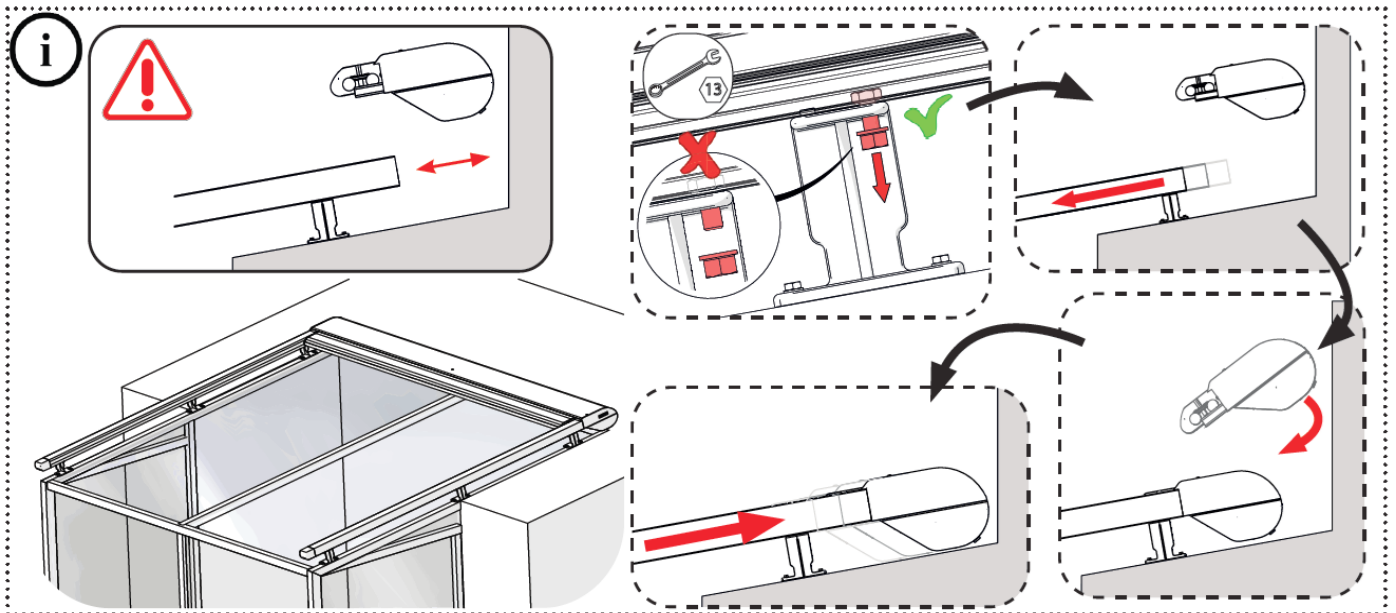
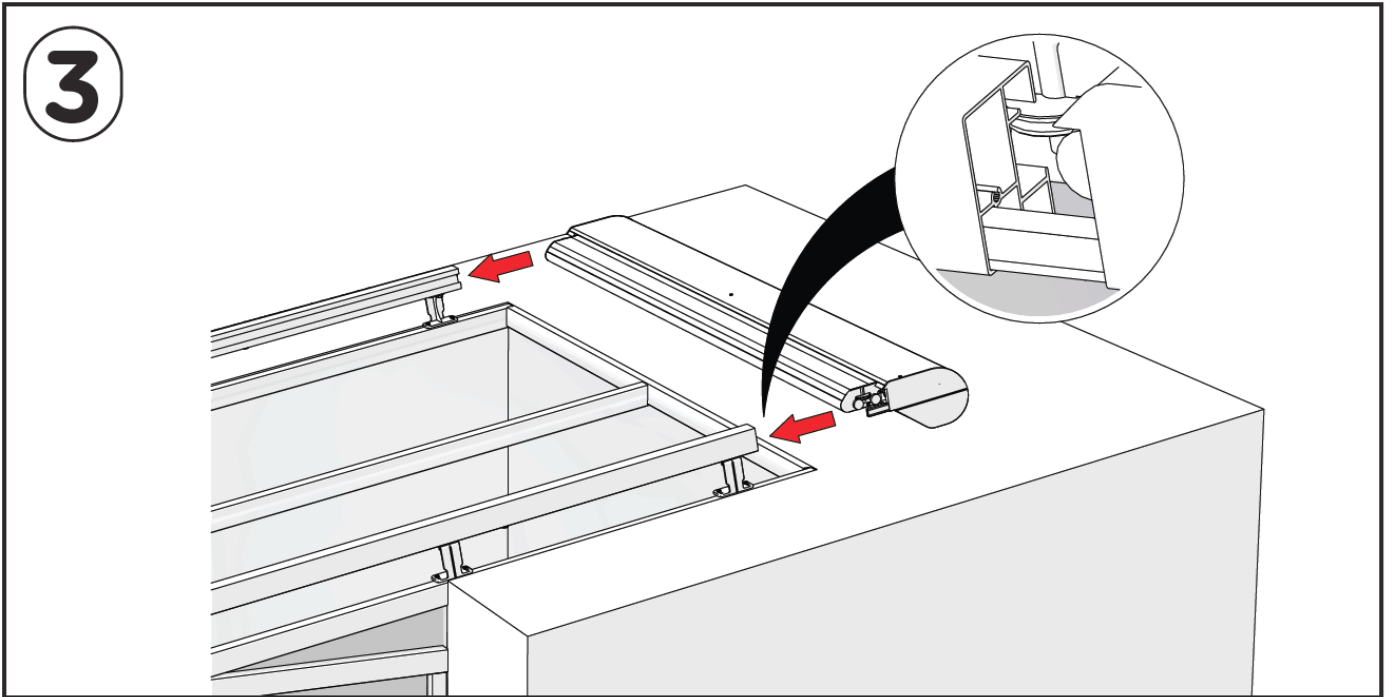

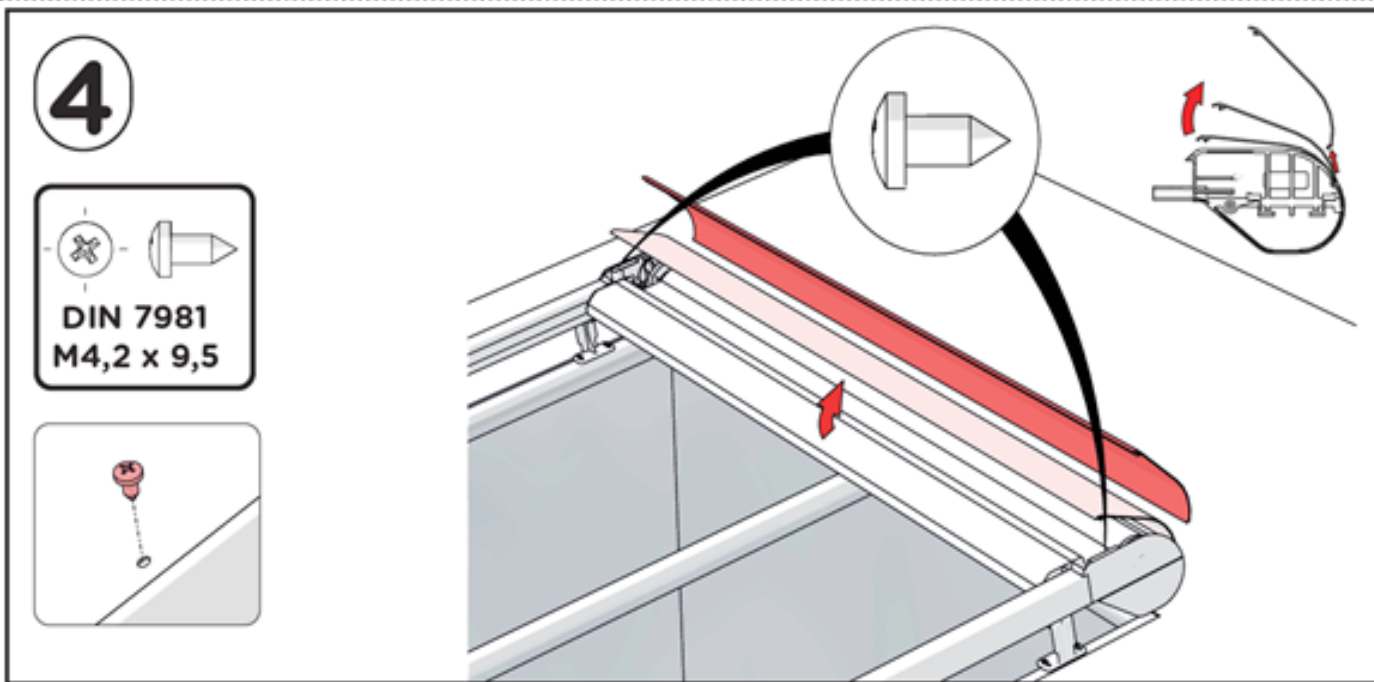

**5**

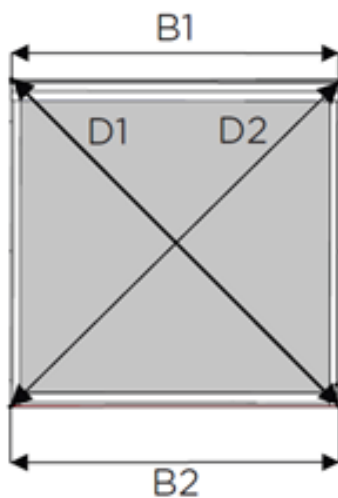
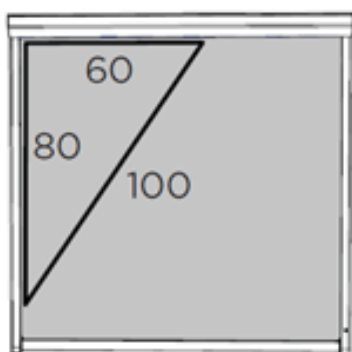

**B1 = B2 & D1 = D2**  
(+/- 2mm) (+/- 2mm)

6

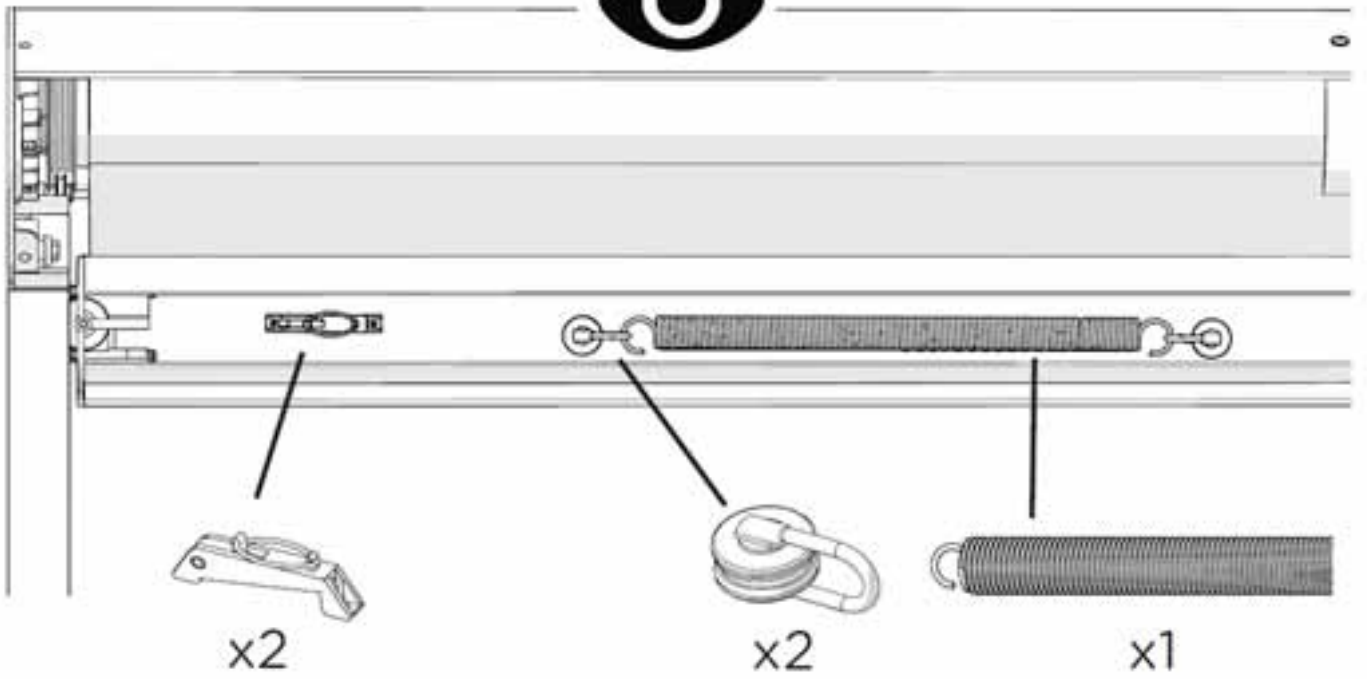
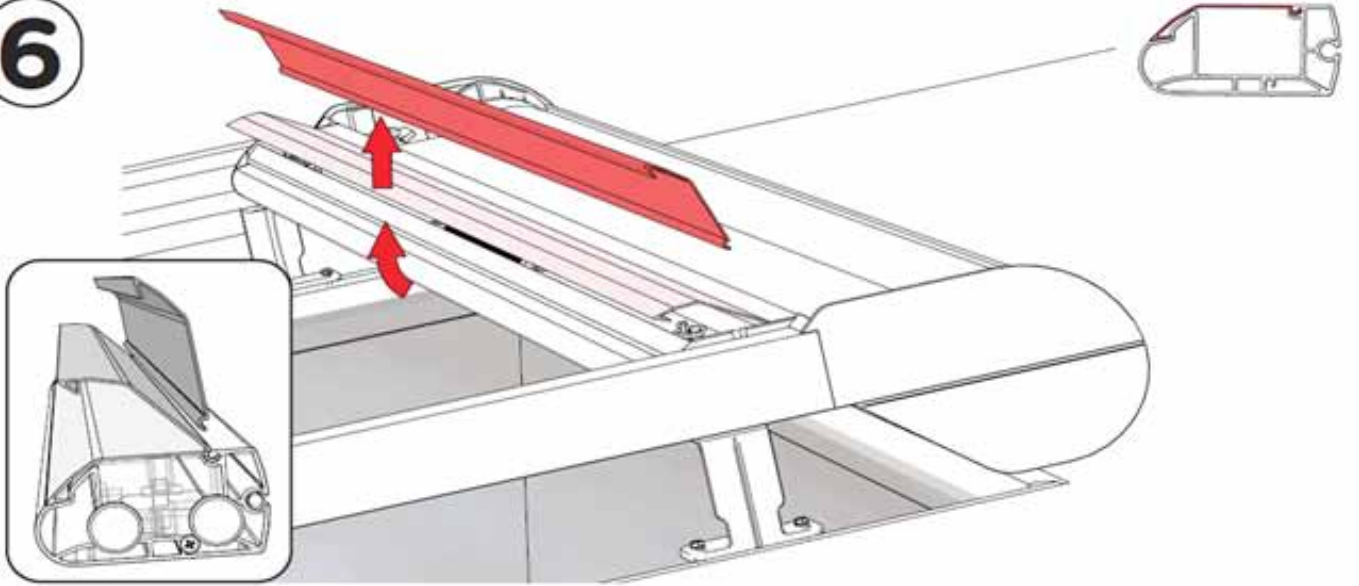

7



CHECK THAT AT LEAST 2 OR 3 TURNS OF CABLE ARE LEFT ON THE CABLE PULLEY.

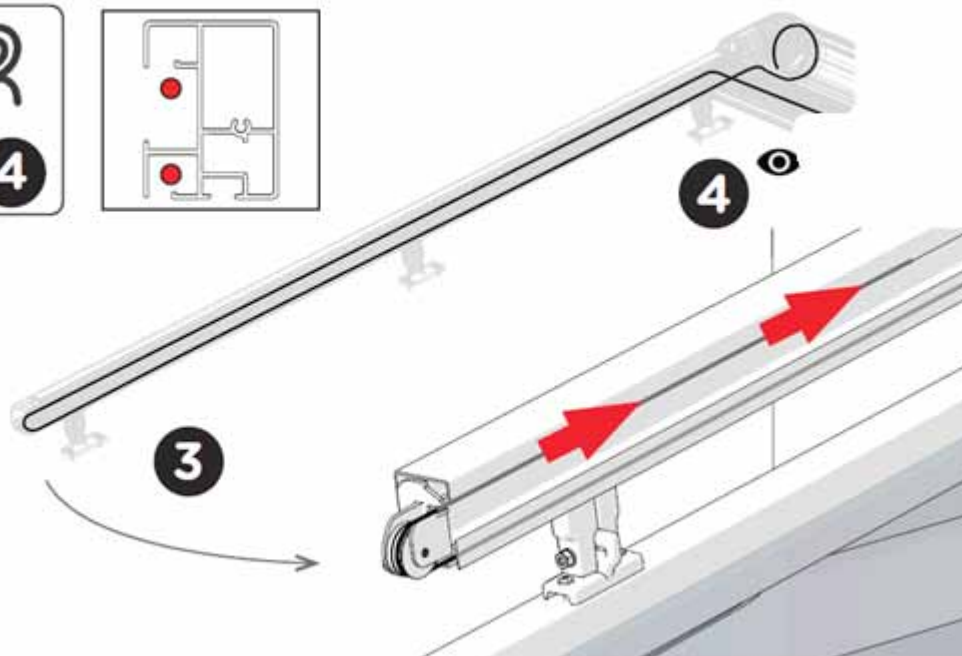
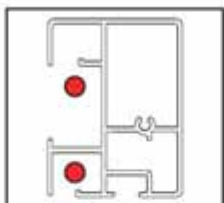
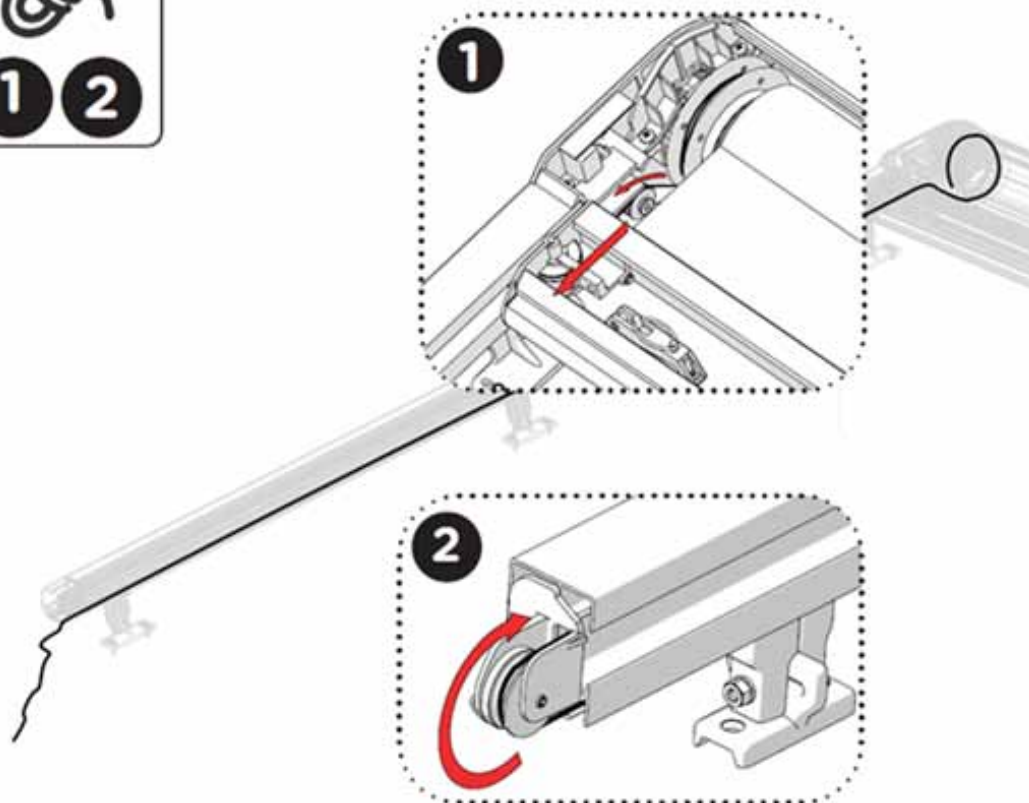

4

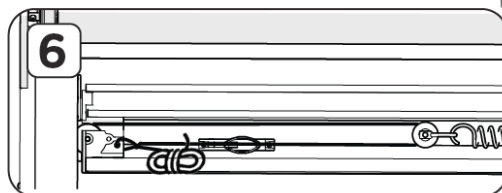
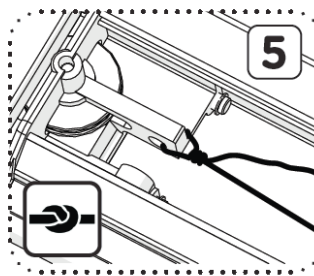
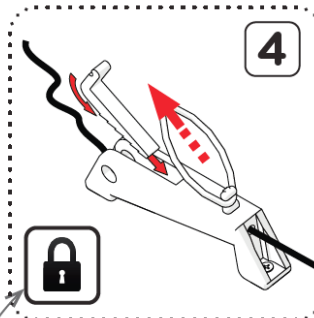
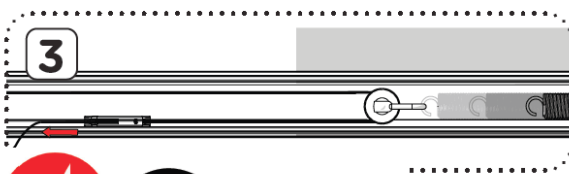
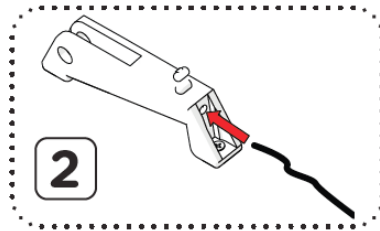
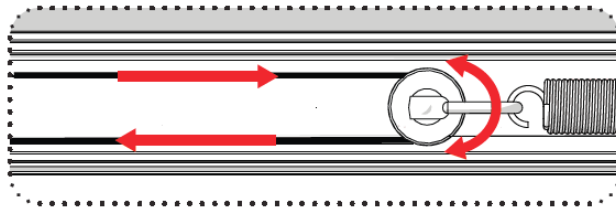
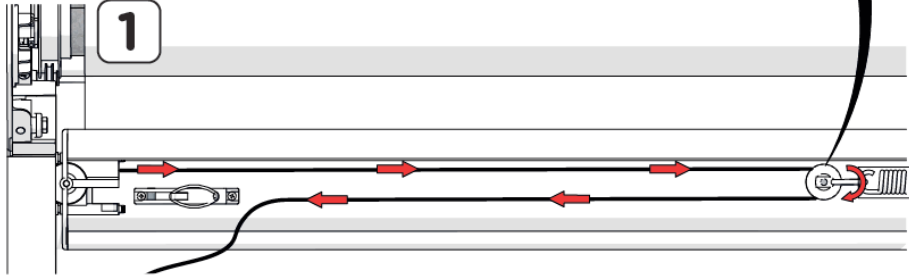
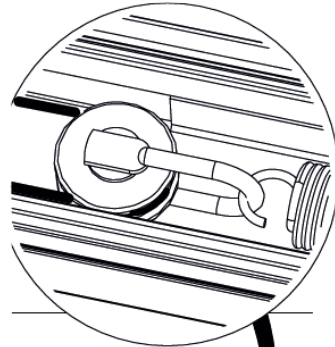
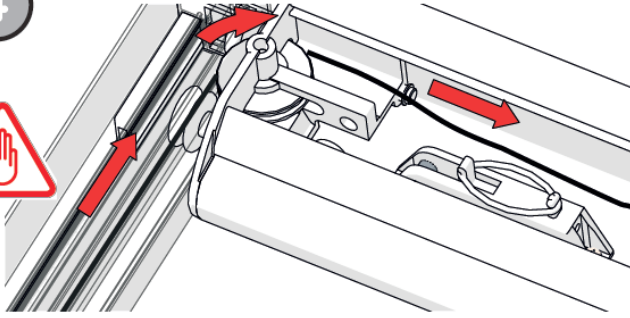
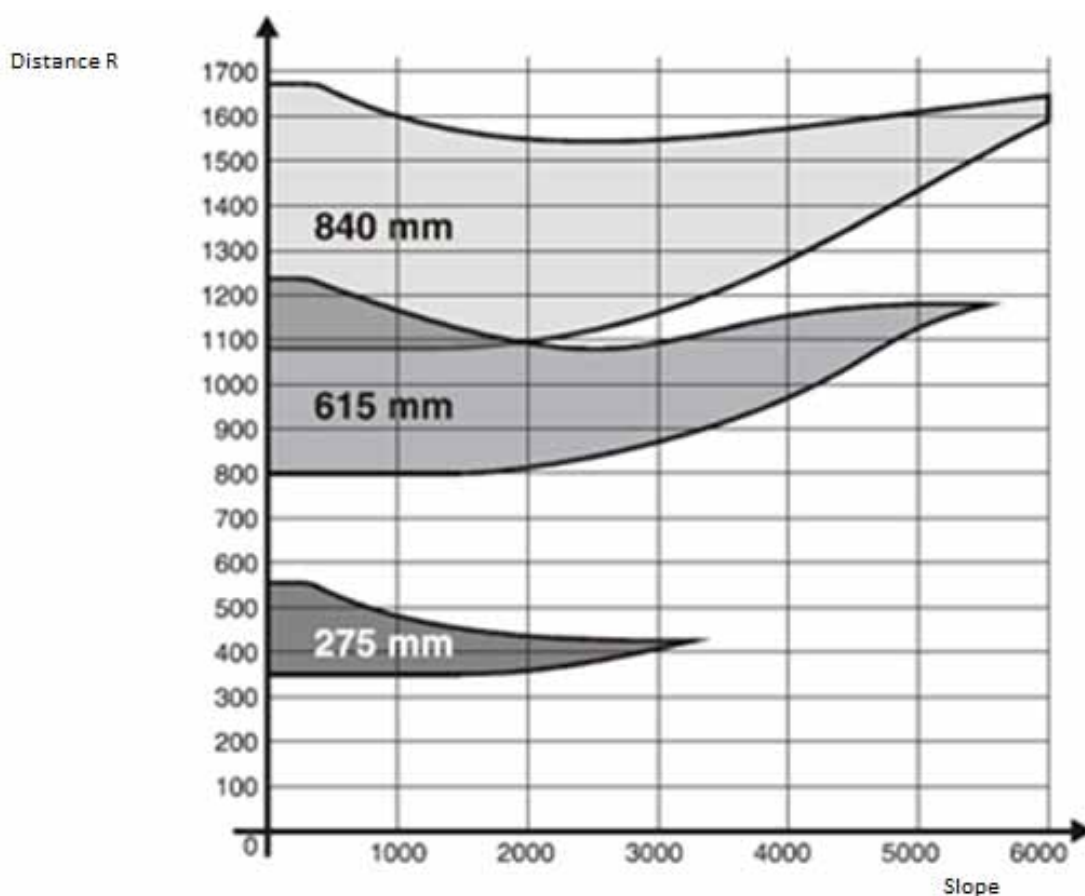
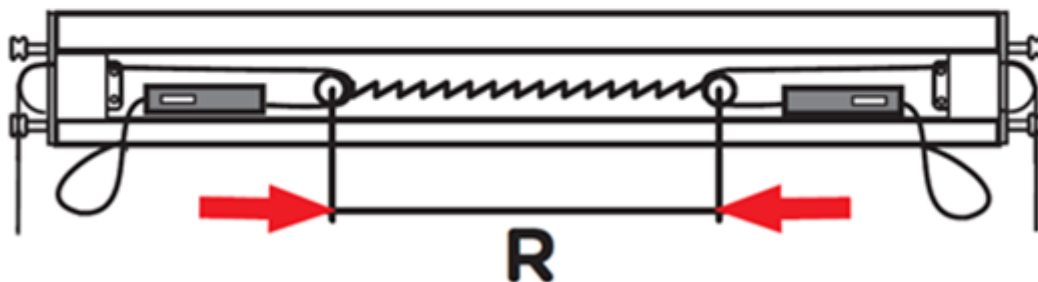
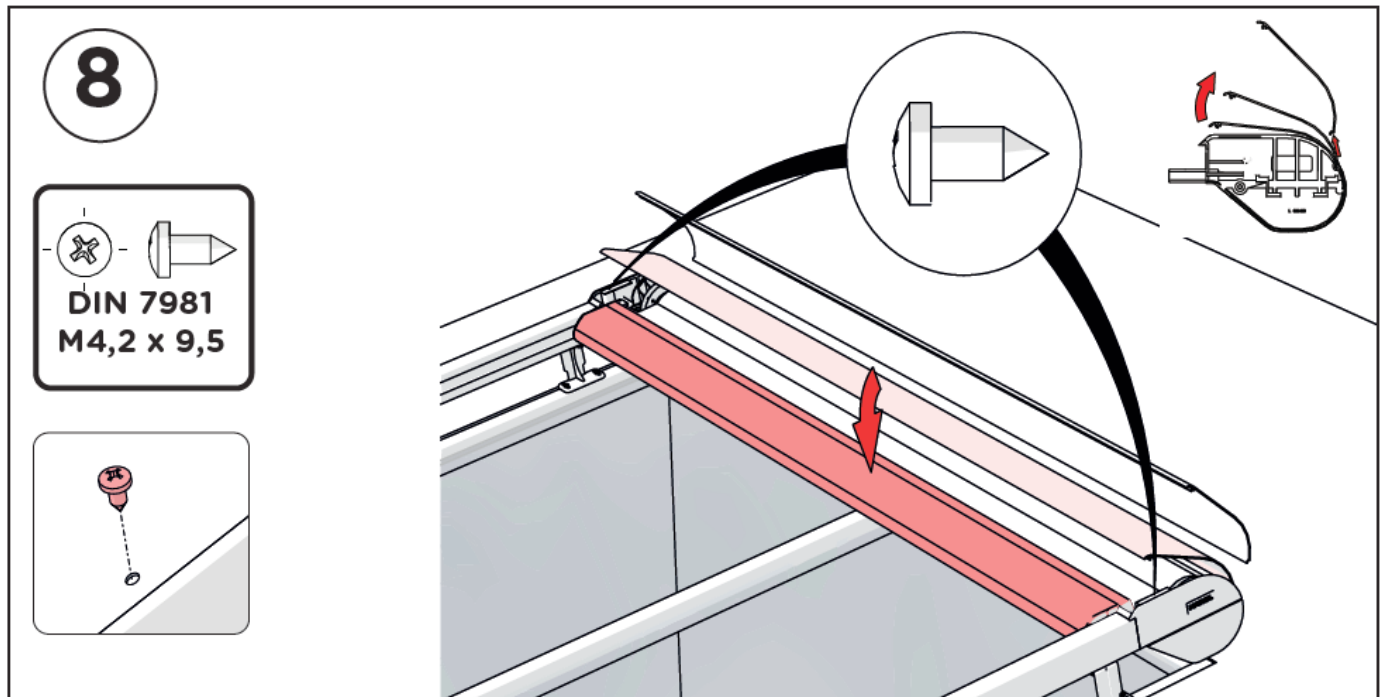
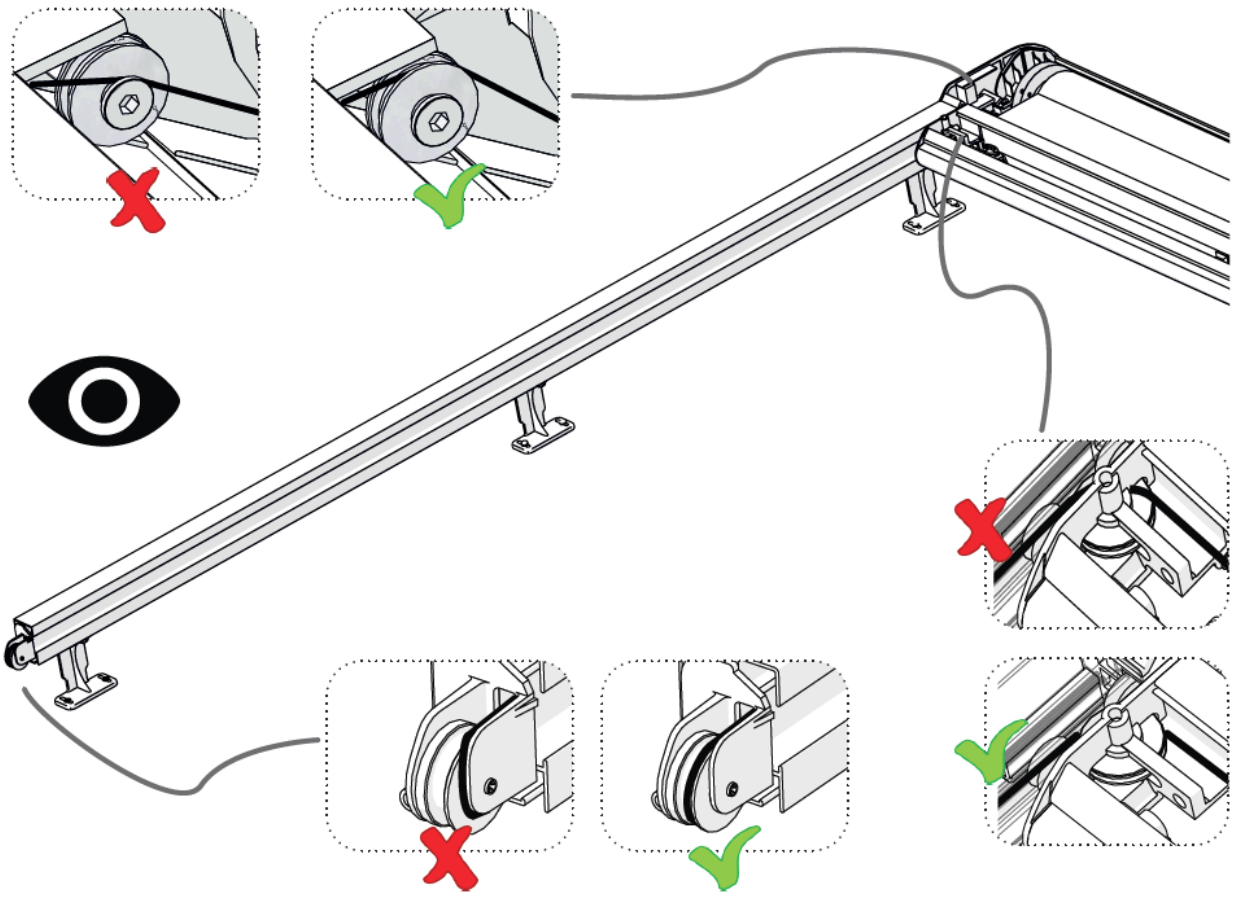

Table spring distance R (in mm)



DEPENDENT ON THE TYPE OF SPRING (650 MM / 850 MM), READ DISTANCE R IN COLORED ZONE.



9

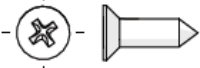

DIN 7982  
M4,2 x 13

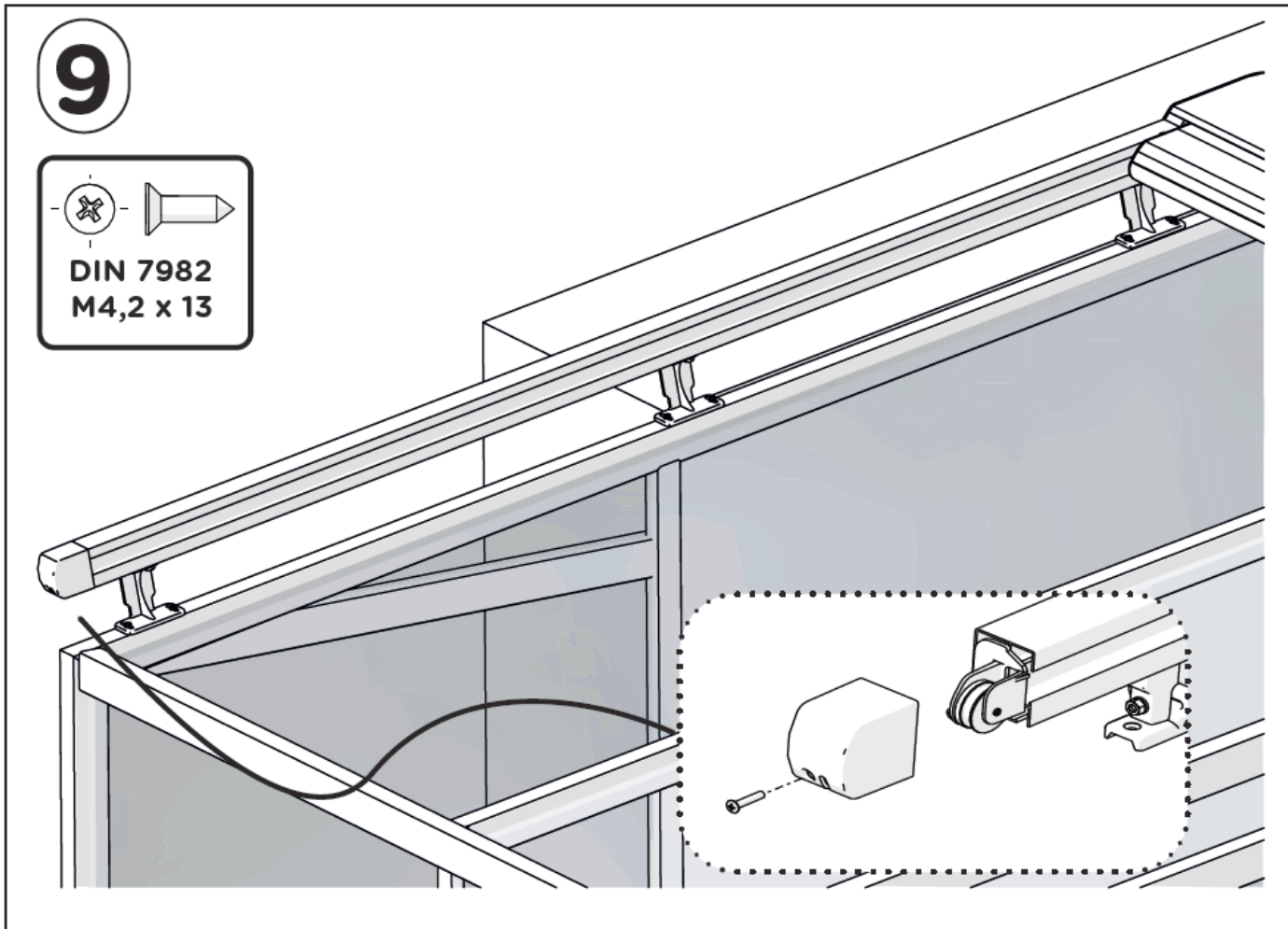

see instruction manual Somfy

10



x1

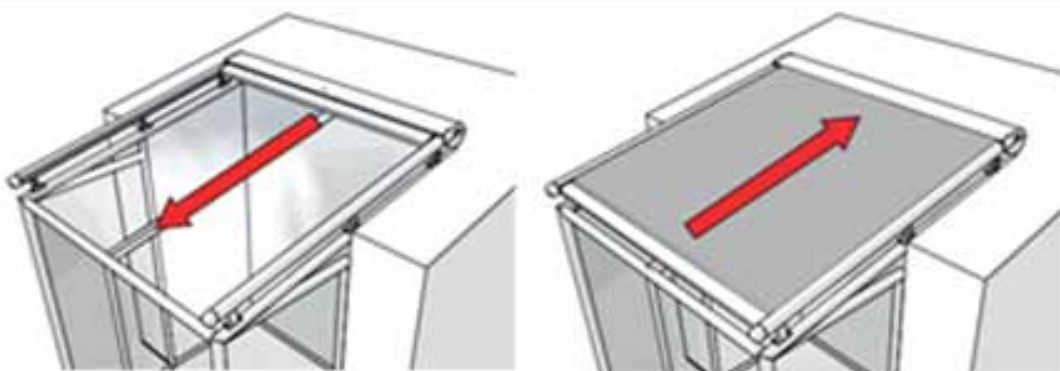

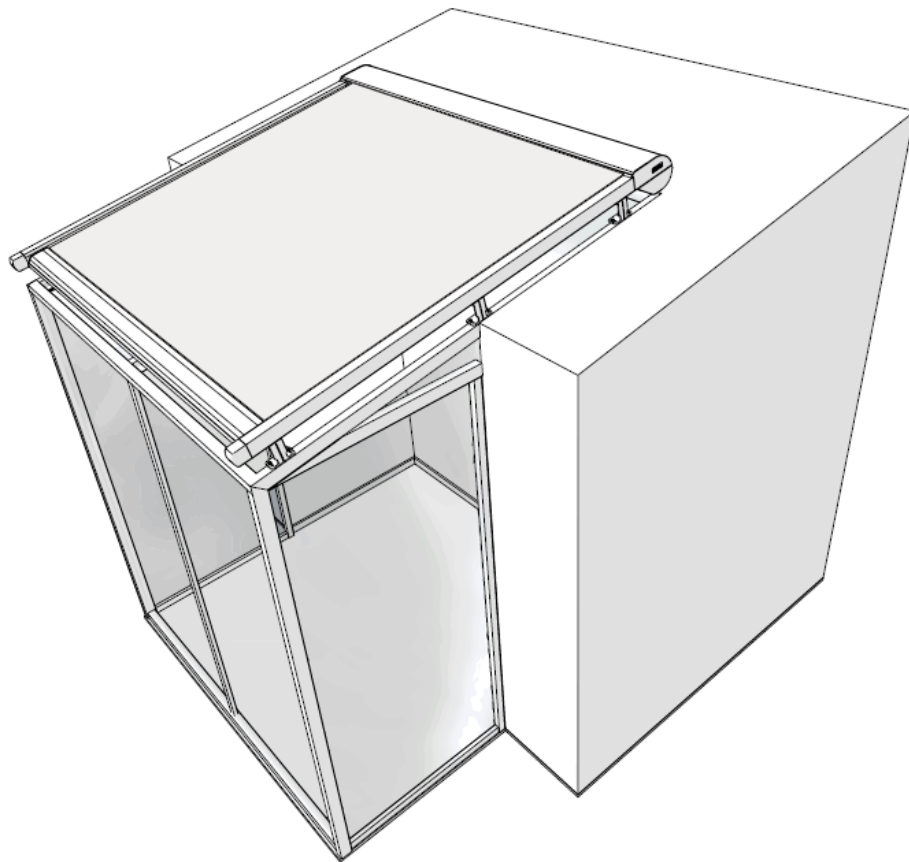
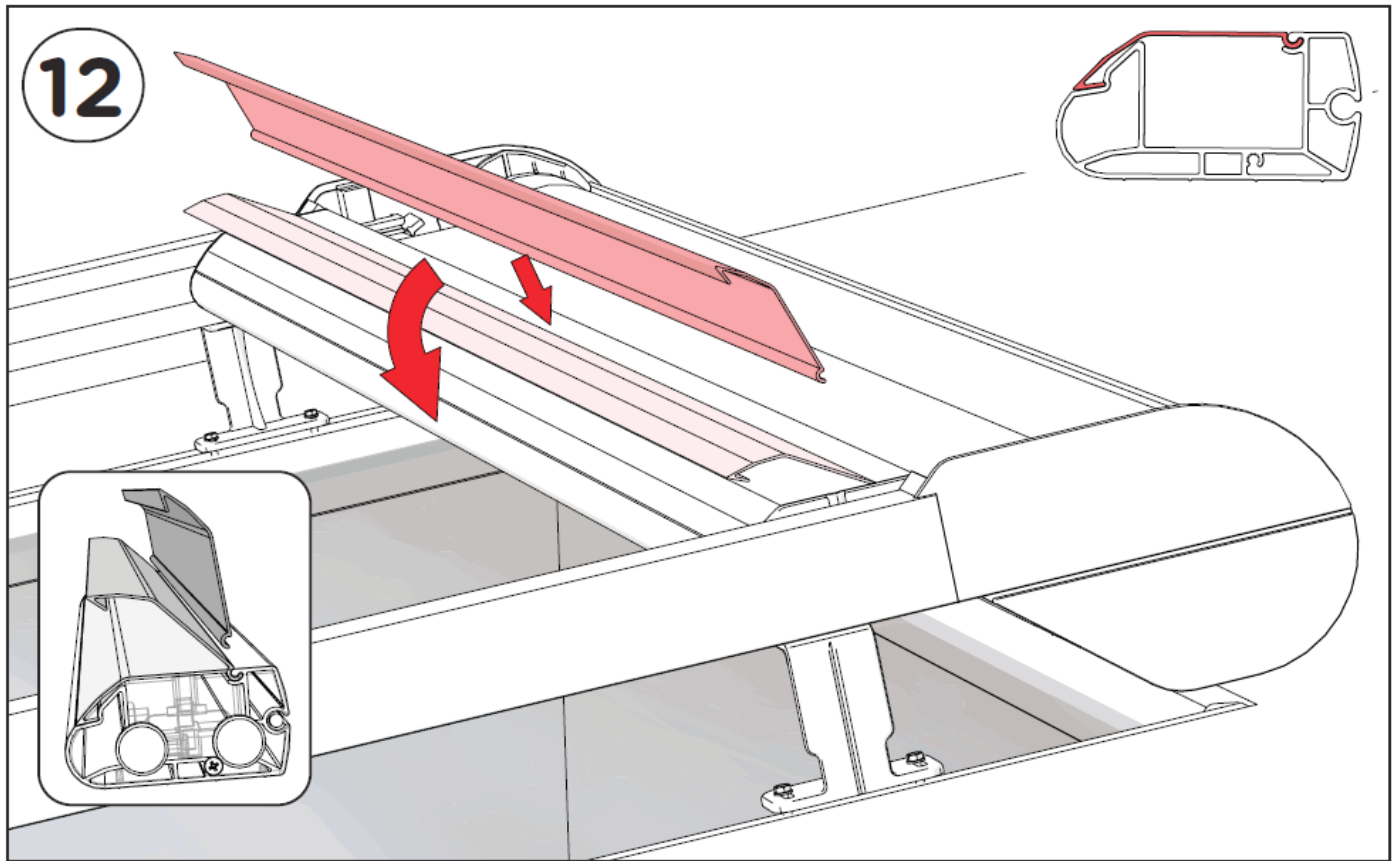

### Coupled

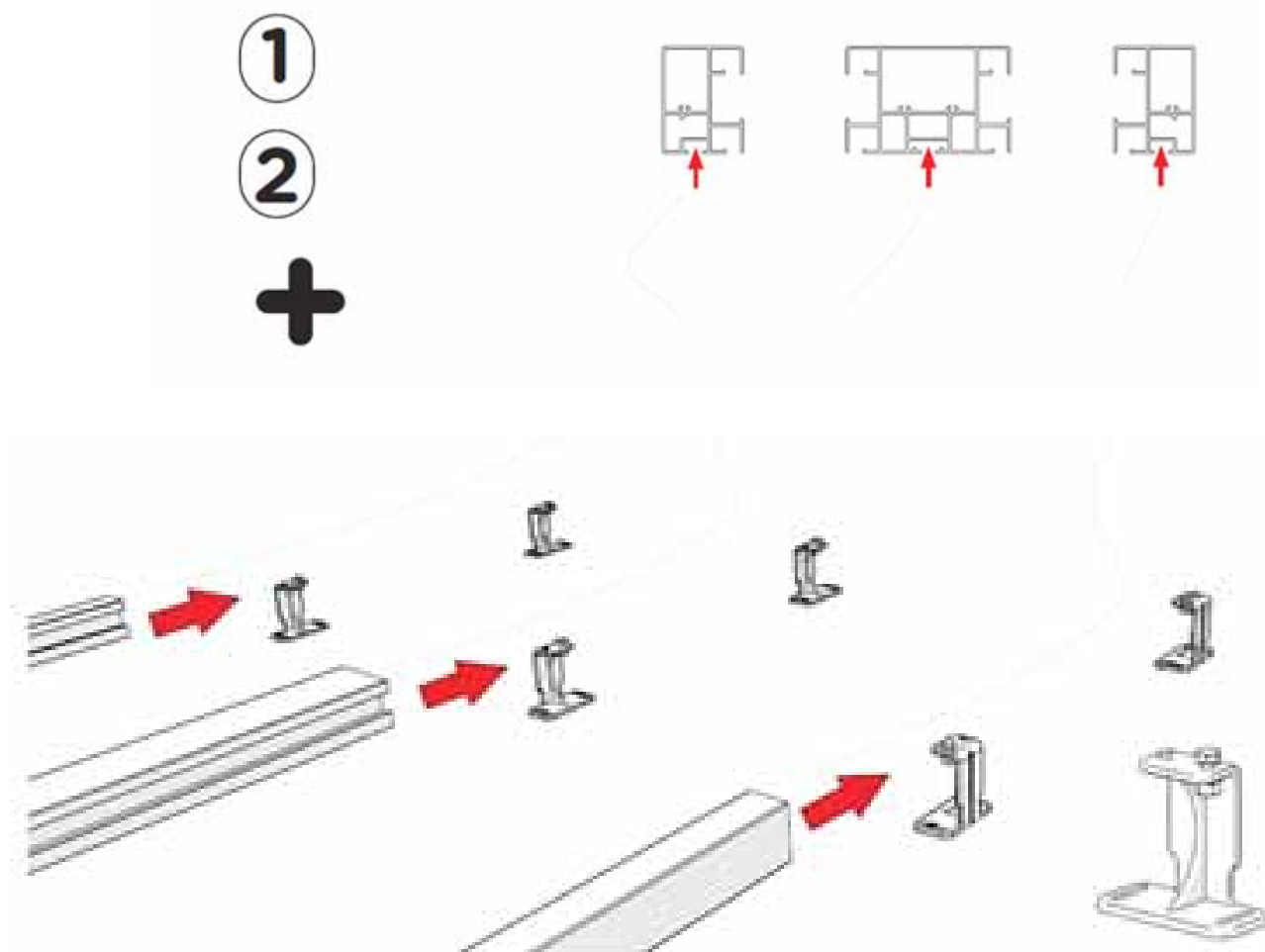
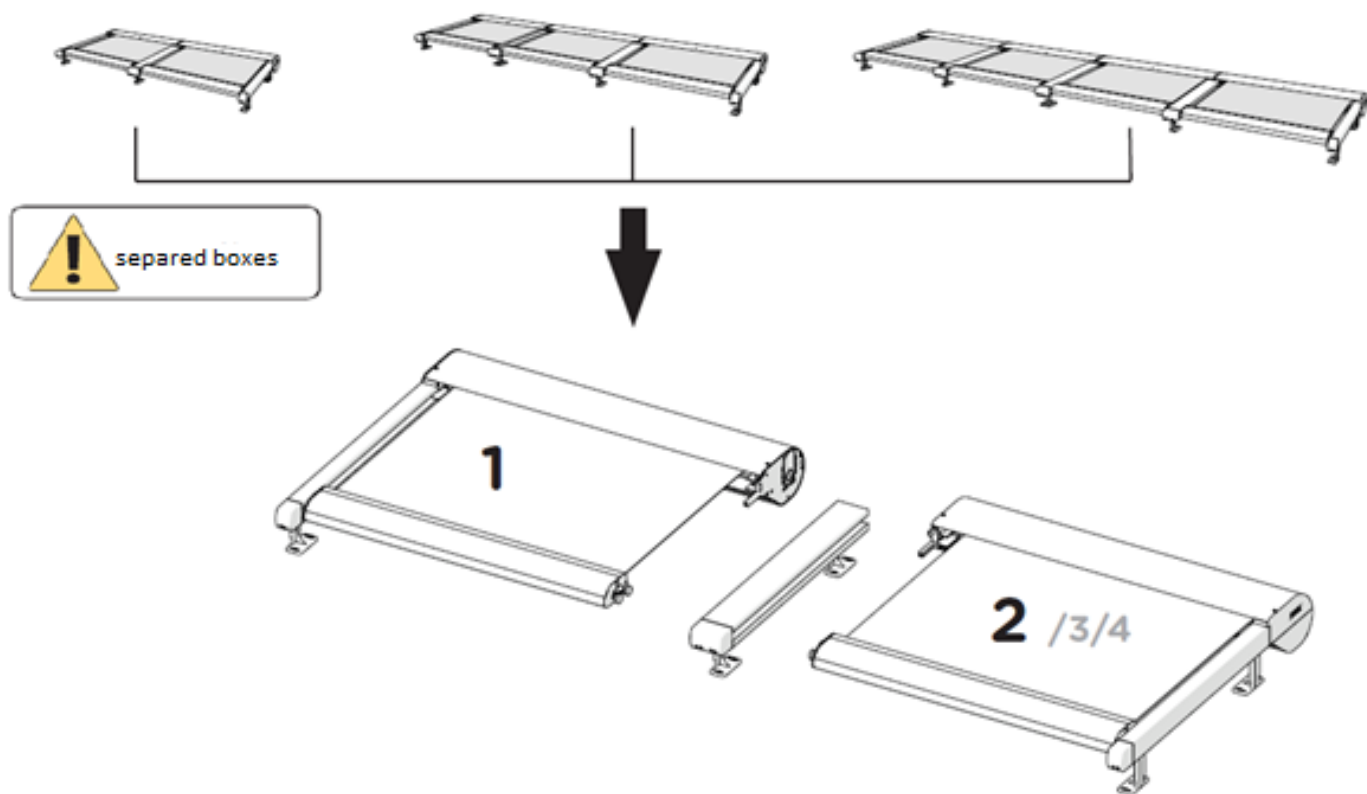

3

+

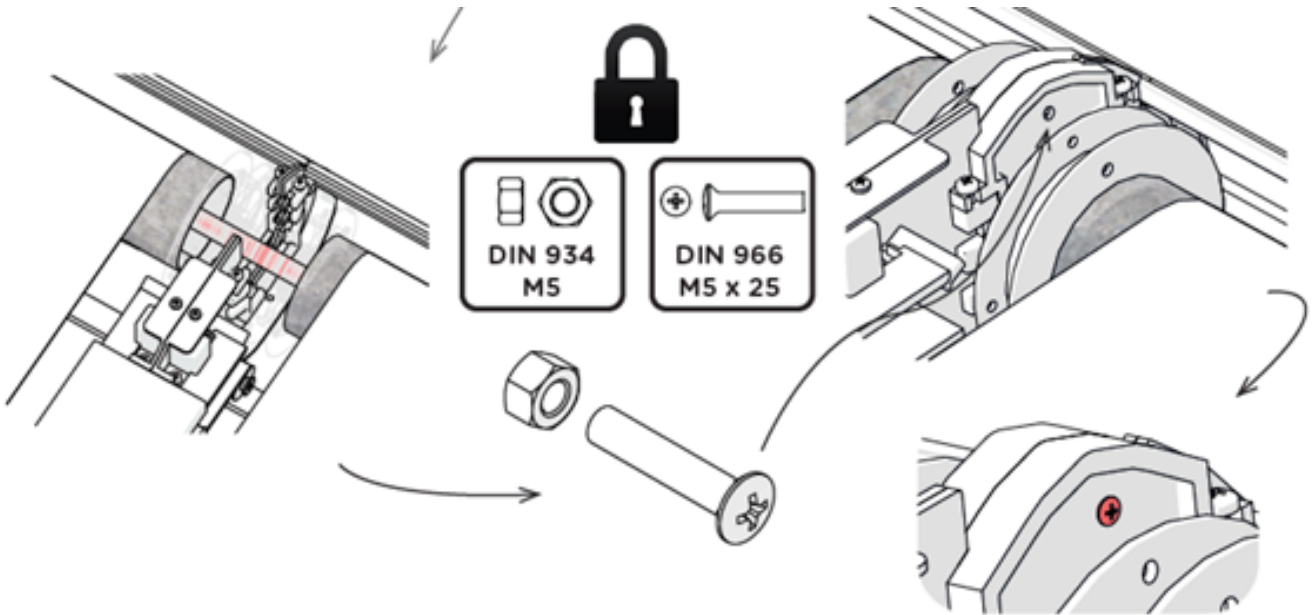
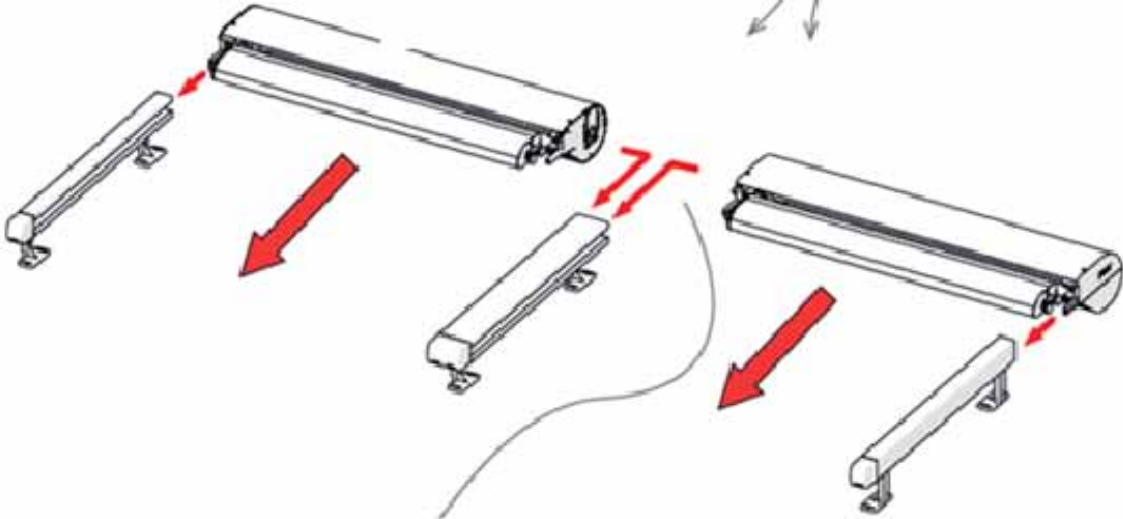
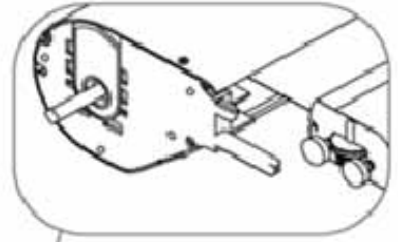
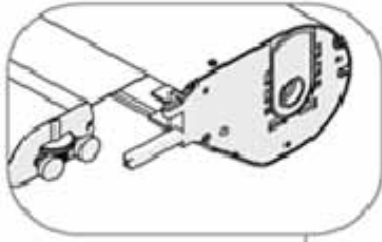

## Veranda HRV08-ZIP



- ▲ Fabric stays stretched longer due to innovative ZIP system with metal spring
- ▲ Compact box helps to create timeless design of Veranda
- ▲ Possibility to connect up to 4 pcs together (common box up to 6 m width of the blind)
- ▲ System variability (fabric can be rolled sideways, bottom-top and top-bottom)
- ▲ It can be mounted from exterior or interior
- ▲ High wind resistance (up to 49 km/h)

**ISOTRA** *Quality*

# VERANDA HRV08-ZIP

## Basic Product Specification

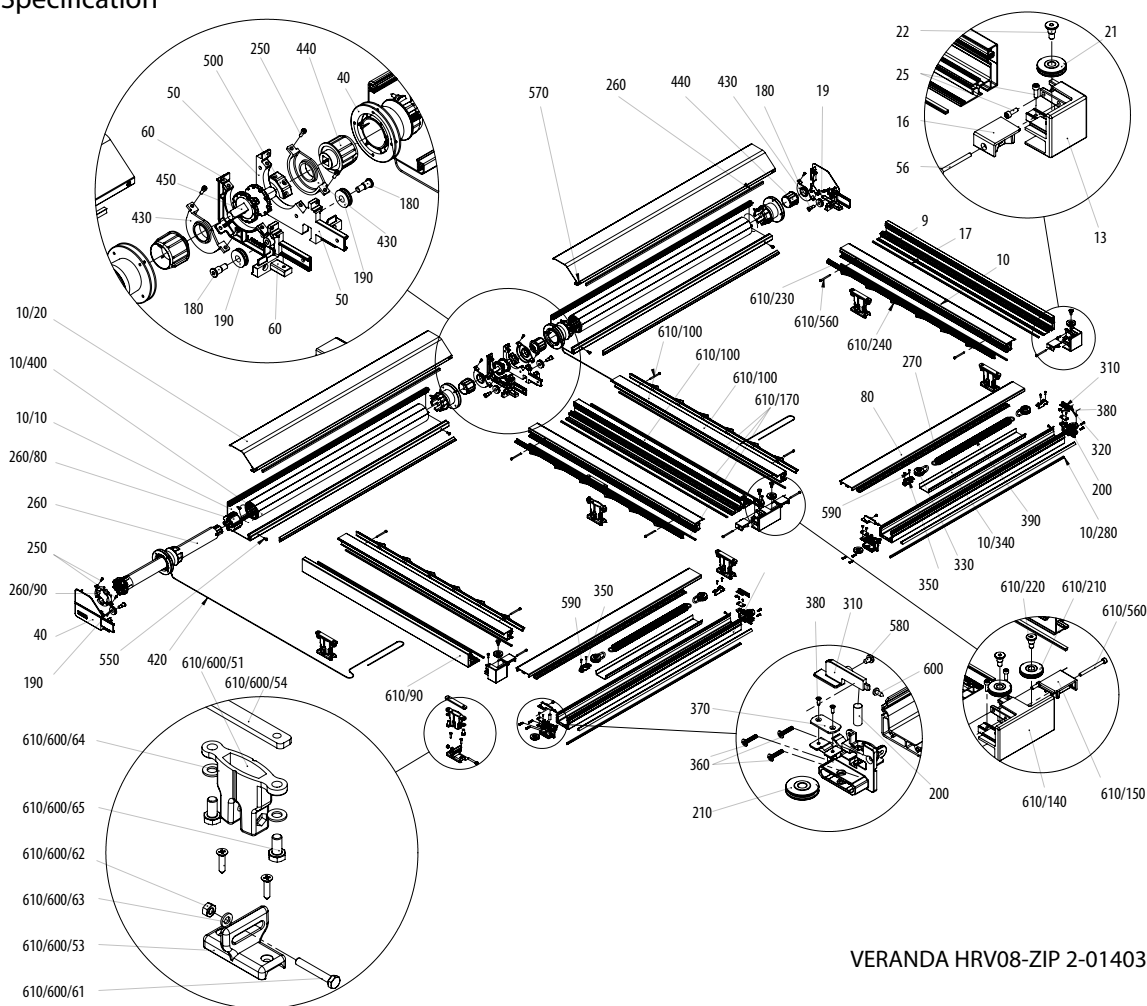

VERANDA HRV08-ZIP 2-01403-0000

### Control

**Motor** – tubular motor 230V (50 Hz) fitted far left and/or far right as required. As standard there is supplied 3 meters long cable (optionally 5 or 10 m), a single-pole surface-mounted switch and plug. Optionally motor with automatic readjustment Orea WT, motor with built-in RTS receiver Orea RTS or motor with built-in IO receiver Sunea IO.

### Fabrics

The fabrics are welded horizontally.

#### Fabrics of the Blackout type:

The opaque layer is located on the side of the window for each type of installation. In the case of outdoor installation, strong winds can cause a slight lifting of the base slat and fabric and therefore 100% blackout cannot always be guaranteed. In the case of Blackout fabrics, the zippers are fastened on the face side and not on the opaque layer, so it is possible that under strong wind or oblique view of the guide rail a piece of cloth from the zipper tape can be seen, but this is of little importance compared to tightness of the fabric (reducing the waves).

### Specification

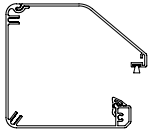
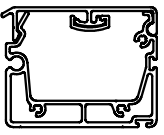
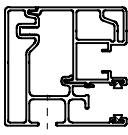
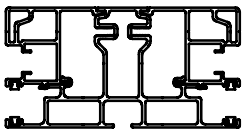
	Upper profile	Bottom profile	Suide guidance		Assembly
			Guide rail		
<b>Dimension (mm)</b>	134 x 118	65 x 50	57,5 x 56	109 x 56	both from the interior and the exterior
<b>Material</b>	Al	Al	Al	Al	
					
<b>Colour</b>	RAL 9010, RAL 9006, RAL 9007, RAL 8014, RAL 7016, RAL 7016S, DECORAL only up to 4000 mm width				

### Standard Dimensions

Control	Width (mm)		Height (mm)	Guaranteed area (m <sup>2</sup> )
	min	max	max	max
motor	850	3000	3500	10,5
motor, Assembly MT1,MT2	850	4000	3500	14

**VERANDA HRV08-ZIP(2-01403-0000)**

position	item name	trade name - abbreviation 2	order number - abbreviation 1
<b>10</b>	<b>Profiles – VERANDA HRV08-ZIP</b>		<b>see Profiles - VERANDA HRV08-ZIP</b>
<b>19</b>	<b>Screen fabric</b>		<b>see Soltis 92 screen fabric sampler</b>
<b>20</b>	<b>Fabric for Verandas</b>		<b>see awnings fabric sampler</b>
40	Side cap - LEFT	VRH 004	6-014684-0000
50	Side cap - central RIGHT	VRH 011	6-014688-0000
60	Side cap - central LEFT	VRH 010	6-014687-0000
180	Side cap peg Ø 10	VRH 012	6-014700-0000
190	Reverse wheel for side-cap - 28x8mm	VRH 094	6-014597-0000
200	Pin smooth cylindrical 8x20,A2 DIN 7	VRH 032	6-014702-0000
210	Wheel for rope Ø2 mm - VZ080	VRH 029	6-014703-0000
250	Screw inbus M4x12, DIN 912, A2	VRH 101	6-014705-0000
<b>260</b>	<b>Motors (SOMFY)</b>		<b>viz strana 30</b>
300	Bearing RIGHT - black	VRH 055	6-014710-9004
310	Bearing cover - LEFT - BLACK - SET	VRH 127	6-014711-9004
320	Bearing cover - RIGHT - BLACK - SET	VRH 128	6-014712-9004
330	Wheel with fork for cord guiding HRV		6-019123-0000
350	Fastening block - cl227	VRH 121	6-014715-0000
360	Woodscrew 3,5x16 DIN 7982 C-H A2	VRH 130	6-014674-0000
370	Fastening board - 16x28x1,25, A2	VRH 122	6-014716-0000
380	Screw - WN 1413 - K25 x 8, A2	VRH 100	6-014717-0000
390	Spring - L=400 mm	VRH 091	6-014718-0000
410	Cylinder cover Ø 67mm - long - VZ080 - BLACK	VRH 046	6-014721-9004
420	HI - TEC cord 2 mm	VRH 022	6-014722-0000
430,432	Holder adjustable - BLACK	VRH 067	6-014723-9004
440,442	Cylinder cover 4square - BLACK	VRH 044	6-014724-9004
450,452	Rod connector	VRH 023	6-014725-0000
500	Connector cover- BLACK	VRH 043	6-014729-0000
550	Woodscrew 4,8x13 DIN 7982 C-H A2	VRH 134	6-014734-0000
570	Screw inbus M4x16, DIN 912, A2	VRH 102	6-014736-0000
580	Screw M4x6 stainless A2, DIN 7985-H	VRH 105	6-014737-0000
590	Woodscrew 2,9x13 DIN 7982 C-H A2	VRH 129	6-014738-0000
600	Woodscrew 3,5x9,5 DIN 7981 CH, A2	VRH 131	6-014739-0000
<b>610</b>	<b>Guiding - rail - LEFT</b>		<b>see Guiding - rail - left</b>
<b>620</b>	<b>Guiding - rail - RIGHT</b>		<b>see Guiding - rail - right</b>

**Profiles - VERANDA HRV08-ZIP (3-03077-PU11)**

position	item name	trade name - abbreviation 2	order number - abbreviation 1
43383	BOX profile - cover	VRH 070	6-014682-0000
44105	BOX profile - bottom	VRH 068	6-014683-0000
25842	Bottom profile	VRH 072	6-014689-0000
29495	Bottom profile - cover	VRH 074	6-014690-0000
10/280	Sealing rofile - ad 33/ad 42 - black	VRH 085	6-014708-9004
10/270	Holder adjustable - BLACK	VRH 066	6-014707-9004
10/340	Rubber pad 1x40mm - black	VRH 020	6-014714-0000
10/400	Winding roller Ø 67x1,25mm - 6m	VRH 125	6-014720-0000

**Guiding - rail HRV08-ZIP - left (2-01405-PU11L)**

position	item name	trade name - abbreviation 2	order number - abbreviation 1
610/90	Guiding channel profile	VRH 088	6-014691-0000
610/100	Guiding channel profile - cap	VRH 089	6-014692-0000
610/110	Guiding channel profile - double	VRH 086	6-014693-0000
610/140	Guiding channel end - cap - central	VRH 039	6-014696-0000
610/150	Guiding channel cover - left	VRH 049	6-014697-0000
610/170	Brush for guiding channel 8mm - black	VRH 025	6-014699-9004
610/210	Wheel for rope Ø 2 mm	VRH 029	6-014703-0000
610/220	Peg for guiding channel Ø 8	VRH 013	6-014704-0000
610/230	Guiding profile for zip	ZPH 145	6-014155-0000
610/240	Spring of guiding channel ZIP	ZPH 147	6-013992-0000
610/560	Screw inbus M4x45, DIN 912, A2	VRH 103	6-014735-0000
610/600/51	Holder low	VRH 018	6-014730-0000
610/600/53	Holder anchorage	VRH 117	6-014732-0000
610/600/54	Assembly board 15x75x5 mm	VRH 059	6-014733-0000
610/600/61	Screw M6x40, Zn DIN 933, A2	VRH 111	6-014740-0000
610/600/62	Nut M6 DIN 934, A2	VRH 057	6-014741-0000
610/600/63	Pad M6, DIN 125-1A, A2	VRH 064	6-014742-0000
610/600/64	Pad M8, DIN 125 A2	VRH 065	6-014632-0000
610/600/65	Screw M8x16, DIN 933, A2	VRH 112	6-014641-0000

**Guiding - rail HRV08-ZIP - right (2-01405-PU11P)**

position	item name	trade name - abbreviation 2	order number - abbreviation 1
620/130	Guiding channel end - cap - right	VRH 037	6-014694-0000
620/160	Guiding channel cover - right	VRH 050	6-014698-0000
620/210	Wheel for rope Ø 2 mm	VRH 029	6-014703-0000
620/220	Peg for GCH End-cap Ø 8	VRH 013	6-014704-0000
620/250	Screw inbus M4x12, DIN 912, A2	VRH 101	6-014705-0000
620/560	Screw inbus M4x45, DIN 912, A2	VRH 103	6-014735-0000

**Weight**

box		2 lateral guides		coupling guide	
length	weight	length	weight	length	weight
1,0m	approximately 13 kg	0,5 m	approximately 2 kg	0,5m	2 kg
1,5 m	approximately 17 kg	1,0m	approximately 4 kg	1,0m	3,5 kg
2,0m	approximately 21 kg	1,5 m	approximately 6 kg	1,5 m	5,5 kg
2,5 m	approximately 24 kg	2,0m	approximately 8,5 kg	2,0m	7,5 kg
3,0m	approximately 28 kg	2,5 m	approximately 10,5 kg	2,5 m	9 kg
		3,0m	approximately 12,5 kg	3,0m	11 kg
		3,5 m	approximately 14,5 kg	3,5 m	13 kg

For a HRV08-ZIP with a width of 1.5 metres and a height of 1 metre, the total weight is approx. 20.5 kg.

## VERANDA HRV08-ZIP

### Basic Product Specification

#### The box

Material: extruded aluminium with powder coating

Wall thickness: 2 mm

Dimensions: 134 mm x 118 mm

Consists of two sections:

- a removable chamfered upper section or cover;
- a fixed lower section.

A fabric guide profile is attached to the fixed section, which guides the fabric out of the box. A brush is secreted in the cover.

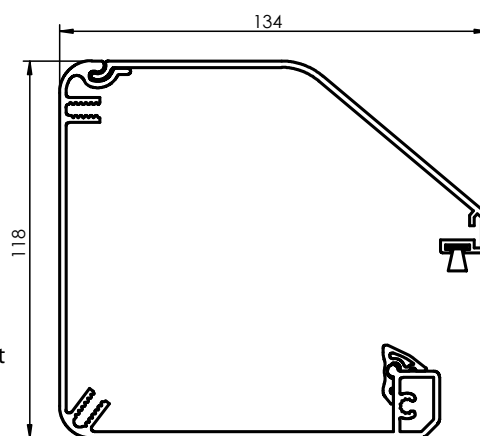

Box

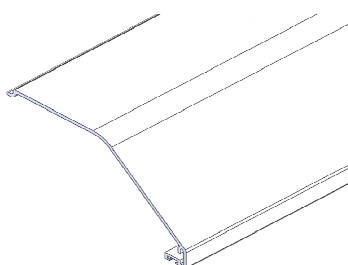
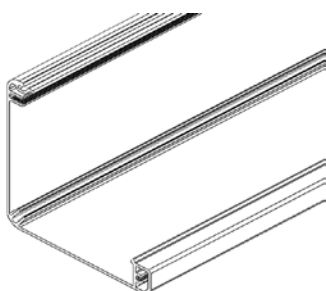

**Box - underside** (6-014682-0000)

**Box - cover** (6-014683-0000)

#### Bottom profile

Material: extruded aluminium with powder coating

Wall thickness: basic section 2 mm

Locking profile 1.5 mm

Function:

- The basic section is provided with a groove to which the fabric can be attached.
- A locking profile: is clipped on to the basic section.
- Runs along the grooves in the lateral guides via specially designed sliding blocks.

Optionally, a rubber or brush can be fitted to the front of the extension pole. In certain fitting situations these can also be fitted to the underside of the extension pole, during installation.

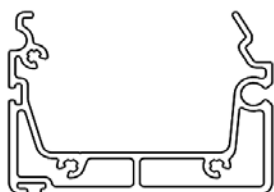
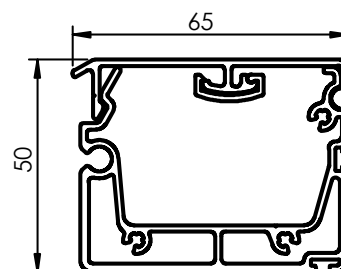

**Bottom profile** (6-014689-0000)

**Bottom profile - cover** (6-014690)

#### Clip-On/Clip-Off profile

Material: extruded PVC clips.

Function: Fixing the fabric in the groove without use of screws, so that the fabric can be taken out in a forward direction, rather than being pushed out sideways.

Handle diameter 3 mm.

Advantage: quick and easy change of fabric

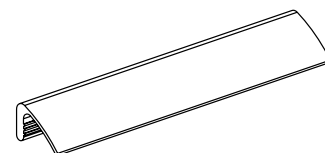

### The fabric roll dia. 67x1,25 mm - 6 m (6-014720-0000)

Material: circular extruded tube made of aluminium, with a groove for attaching the fabric.

Function: rolling the fabric up and down

Diameter: Ø67 x 1.8 mm.

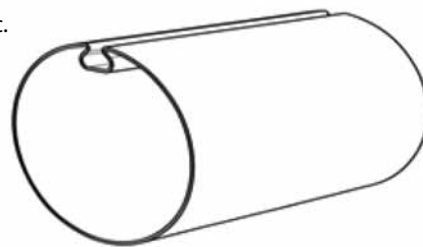

### The separable guide rails

Material: extruded aluminium with powder coating

Wall thickness: 1.5 mm

Two types:

- Lateral guides: installed on outer sides, with a rail slot on one side only.
- Coupling guides: installed in the middle, with a rail slot on either side.

The profiles have a hollow chamber into which the support pins of the side caps fit.

Aluminium end caps coated to match the frame.

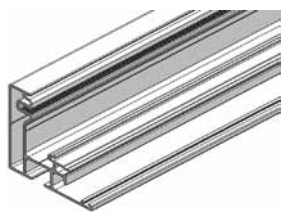
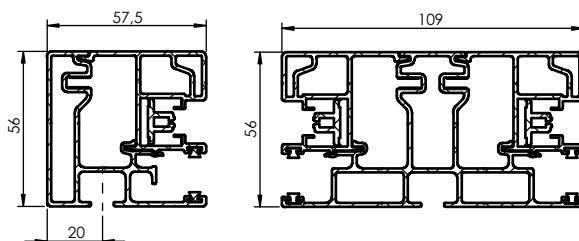

**Guide rail profile** (6-014691-0000)

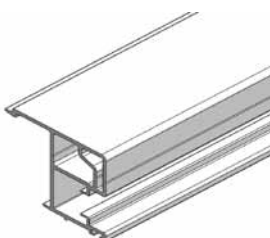

**Guide rail profile - cover** (6-014692-0000)

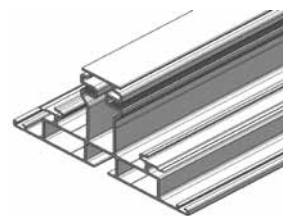

**Guide rail profile - double** (6-014693-0000)

### Zipper guide profile

Material: extruded PVC clip profile

Function: Absorption of the zipper profile on the fabric to keep the fabric tensioned with the aid of stainless steel springs.

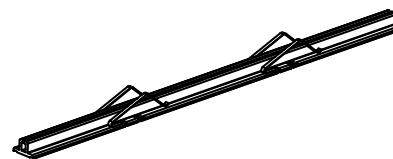

### The consoles

Material: high-pressure-cast aluminium with powder coating.

Colour: colour of frame.

Dimensions: 134 x 118 mm.

There are 2 types of consoles: side consoles and coupling consoles.

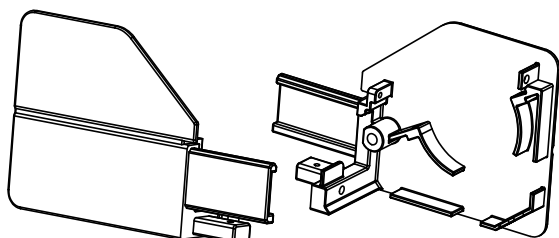

**Console left/right** (6-014684 / 6-014685)

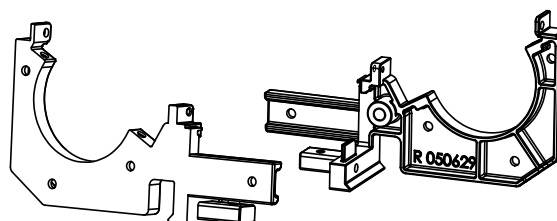

**Console middle - left/right** (6-014687 / 6-014688)

### The sliding blocks

Material: black plastic injection moulding

Function:

- Connection of extension pole and guide rails, fitted with a sliding surface that meshes into the running surface of the guide rail.
- These are screwed into the left and right of the end of the extension pole.

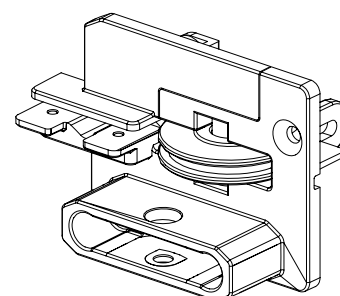

### Guide rail covers

Material: high-pressure-cast aluminium with powder coating.

Colour: colour of frame

Function:

- To cover the guide rail
- Turn-over wheel cord

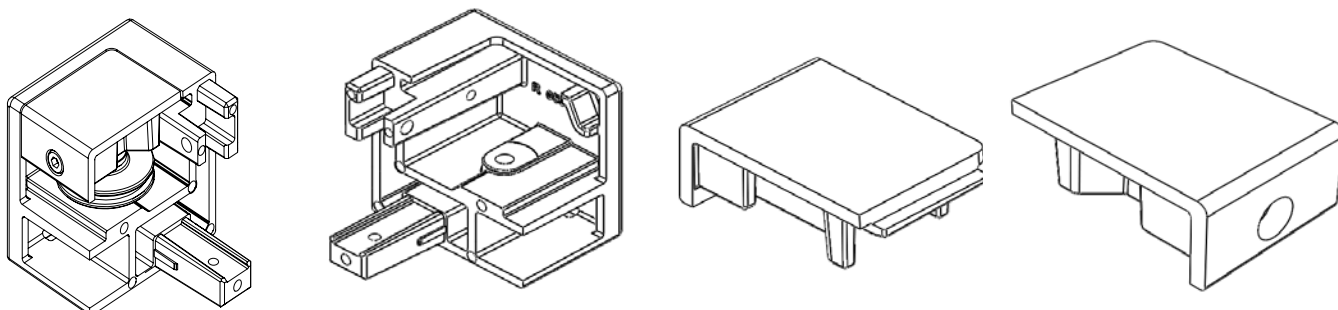

### The tension system

Material: the castors, axles, etc. are made of non-corroding materials.

Function: fabric and extension pole can be constantly kept under tension via a spring, castors and a cord of Ø2 mm.

This keeps the fabric at a certain distance from the glass roof when unrolled, so that there is a ventilation space between the sunblind and the glass roof (elimination of accumulated heat).

### Connector

Material: Corrosion resistant

Function: pairing of two parts of fabric

Adjustable in 8 steps

Warning: Bottom profiles may not fully extend and retract at the same time, as free play may appear in the connection. For coupled awnings, drive with a motor located on the widest part is therefore recommended.

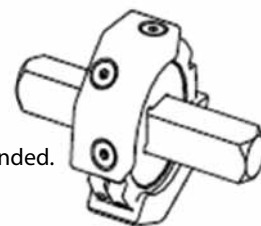

### Mounting of the guide rails

#### S: Standard aluminium bracket

Material: aluminium version, with powder coating adapted to the colour of the frame.

The attachment system is in two parts:

- The upper part: attached to the bottom of the lateral and central guides.
- The lower part, comes in two versions:

#### A: Low bracket standard SA

- for Veranda roof profiles with glass above and wooden pergola and veranda systems,
- is screwed into the wood or into the groove at the top of the profiles into which the rubber seal is fixed. (fitting A)

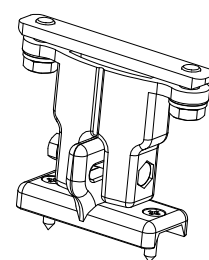

**Low bracket standard SA**  
(2-01408-PU11X)

#### B: High bracket SB

- for Veranda profiles with the glass beneath and screwed into the veranda roof profile with two bolts. (fitting B)
- The upper and lower parts can be adjusted laterally to one another. This allows small positioning deviations between guide profile and Veranda profile to be absorbed.

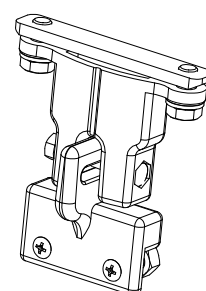

**Hight bracket SB**  
(2-01409-PU11X)

#### Z: without brackets

- Attention: the fabric will always droop a little but must never touch the glass.

## Raised brackets

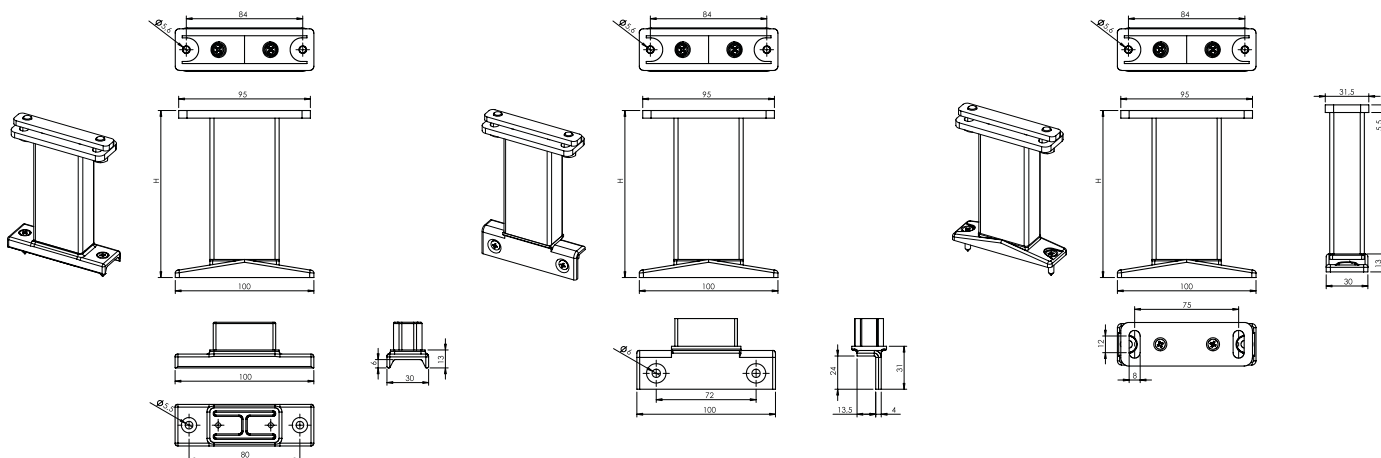

**Bracket VL Av** (2-01410-PU11X)

**Bracket VL Bv** (2-01411-PU11X)

**Bracket VL Cv** (2-01412-PU11X)

The clearance between the guide rail and the glass profiles can be increased by means of elevated supports. When doing this, take into account the fact that the veranda profiles, when using elevated supports, will be subject to heavier loads. For this reason, they can only be used when there is no danger of them twisting. If required, each guide rail must be supported. The elevated supports are available in lengths of 120 mm, 200 mm, 300 mm or 400 mm. The maximum permitted distance between two attachment points of a guide rail is 1600 mm.

### Pre-drilled guide rails along the bottom

### Pre-drilled guide rails in the side

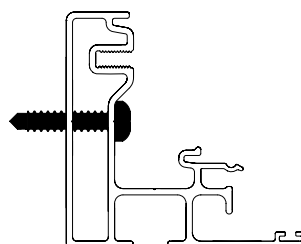
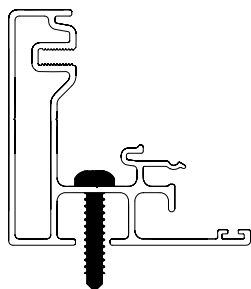

- If you choose to pre-drill the guide rails no supports will be provided.
- Holes of  $\varnothing 5$  mm will be provided, at max. 500 mm distance apart.

### Fixing on the wall

Additional fitting options:

If fixing methods A or B are not possible, an option is to fix against a wall. There are 3 standardised L-profiles. (Always to be used with flat supports Cv)

Available in the following sizes:

- Type L1 = 50 x 30 x 3 mm
- Type L2 = 100 x 50 x 3 mm
- Type L3 = 130 x 50 x 5 mm

For extension length up to 3 m, only 1 profile is used.  
For extension length over 3 m, 2 profile pieces are used.

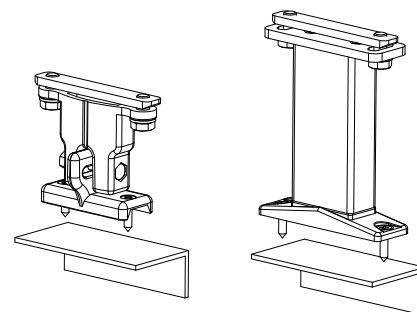

Fixing on the wall

### Coupling of 2 lateral guides

Coupling duo set:

- Consists of: The coupling plate and coupling angle with the requisite screws, nuts and washers.

- Function:

- When using an elevated support in the middle, the profile of the elevated support is directly fixed to the coupling plate. In that case, the upper part of the elevated support will not be used.
- If the standard support is placed in the middle, the upper part of the support should be replaced by the coupling angle.
- If the support is placed left or right on the guide rail, the coupling will be done independently of the support, by mounting the coupling plate behind the support.

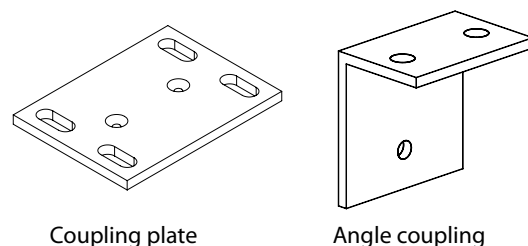

Coupling plate

Angle coupling

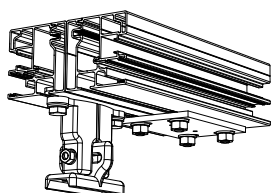

Positioning support under left or right guide rail.

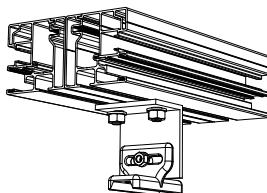

Positioning standard support in the middle.

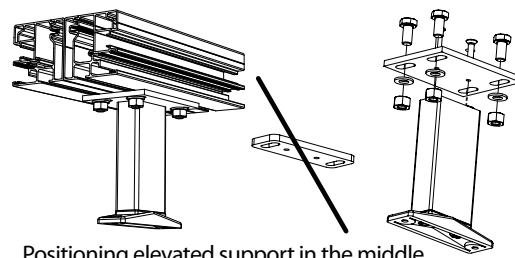

Positioning elevated support in the middle

Height (mm)	Quantity (pcs)
1600	2
3200	3
3500	4

With the Porch HRV08-ZIP, it is possible to combine maximum of 4 porches. If the total ordered width of the coupled porches is less than 6 m, they are delivered in a common box. It is necessary to enter dimension „B“. Provided the total width exceeds 6 m, they will be delivered in two separate parts to be joined at the assembly site.

### Technical options – verandas coupling

Typ	Maximum width (m)									Max. area	Number of verandas	Number of motors
	0,85	1,7	2,55	3	3,4	5	6	8	10			
Type 1		1 veranda								10,5 m <sup>2</sup>	1	1
Type 2		2 verandas								17,5 m <sup>2</sup>	2	1
Type 2		2 verandas								21 m <sup>2</sup>	2	2
Type 3		3 verandas								28 m <sup>2</sup>	3	2
Type 4		4 verandas								35 m <sup>2</sup>	4	2

Note: Two porches in one box and with one engine can be up to maximum width of 5 m. More than 5 m, 2 motors are required.

## Control

Drive via tubular motor 230 Volt (50Hz) fitted far left or far right as required. Control location when viewed from the outside. As standard there is delivered 3 m long cable and a single-pole surface-mounted switch.

Optionally:

- Cable 5 or 10 m
  - The distance can be increased by fitting a junction box
  - without switch
  - **Motor with automatic readjustment; blind will always be completely closed (Orea WT):**
    - without control buttons; end points to be adjusted via cable, via an adjustment set.
    - connectible in parallel (number determined by type of switch).
    - 3 m electric cable.
    - single pole surface-mounted switch.
  - **Motor with built-in RTS receiver (Orea RTS):**
    - 5 m electric cable - optional 10 m electric cable.
    - with RTS wall transmitter - optionally without RTS wall transmitter.
  - **Motor with built-in IO receiver (Sunea IO):**
    - 5 m electric cable - optional 10 m electric cable
    - with IO wall transmitter - optionally without IO wall transmitter
- RTS and IO motors are supplied with the options "back release" and "reduced closing force" activated

Exits (cabling)

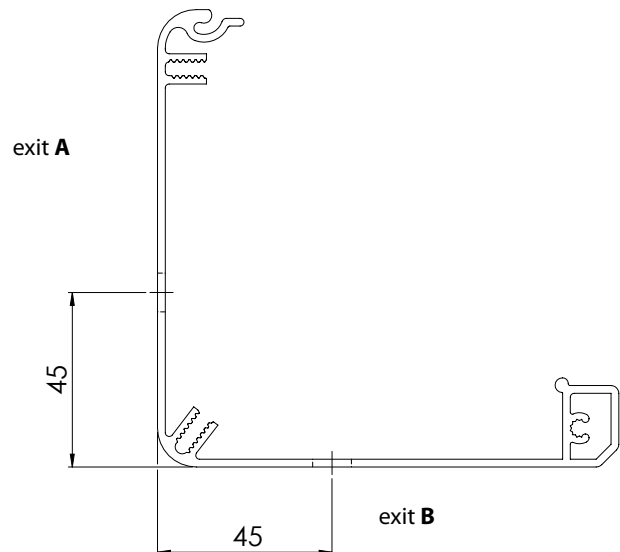
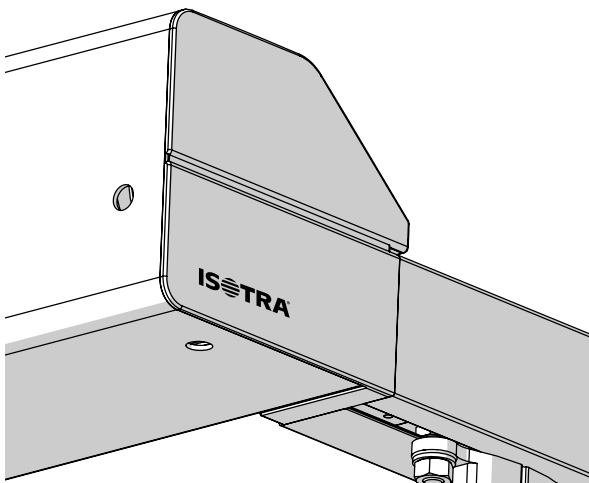

## Accessories:

- Relay boxes ,
- Wind-and-solar control,
- Time switches,
- Remote control,
- etc.

## Motor control

Types of motors

### VERANDA HRV08-ZIP

item name	trade name - abbreviation 2	order number - abbreviation 1
Motor OREA 50 WT 40/17	MR 096/40	6-001550-0040
Motor OREA 60 WT 55/17	MR 096/55	6-001550-0055
Motor OREA 60 WT 70/17	MR 096/70	6-001550-0070
Motor OREA 60 WT 85/17	MR 096/85	6-001550-0085
Motor OREA 50 RTS 30/17	MR092/30	6-011171-0030
Motor OREA 50 RTS 40/17	MR 092/40	6-011171-0040
Motor OREA 60 RTS 55/17	MR 092/55	6-011171-0055
Motor OREA 60 RTS 70/17	MR 092/70	6-011171-0070
Motor OREA 60 RTS 85/17	MR 092/85	6-011171-0085
Motor Sunea 50 io 40/17	MR 134/40	6-012559-4017
Motor Sunea 60 io 55/17	MR 134/55	6-012559-5517
Motor Sunea 60 io 70/17	MR 134/70	6-012559-7017
Motor Sunea 60 io 85/17	MR 134/85	6-012559-8517

### Types of motors (BECKER) for Veranda HRV08-ZIP

item name	trade name - abbreviation 2	order number - abbreviation 1
Motor BECKER 50 E 40/17	17BE	6-017852-0040
Motor BECKER 60 E 60/17	17BE	6-017852-0060
Motor BECKER 50 E 40/17	BC40	6-017852-0040
Motor BECKER 60 E 60/17	BE60	6-017852-0060
Motor BECKER 60 E 70/17	BE70	6-017852-0070
Motor BECKER 60 E 120/11	BE120	6-017852-0120
Motor BECKER 50 C 40/17	16BC	6-017853-0040
Motor BECKER 60 C 60/17	16BC	6-017853-0060
Motor BECKER 50 C 40/17	BC40	6-017853-0040
Motor BECKER 60 C 60/17	BC60	6-017853-0060
Motor BECKER 60 C 70/17	BC70	6-017853-0070
Motor BECKER 60 C 120/11 PLUS	BC120	6-018886-0120

Note: E=electronic motor, C=radio motor

# VERANDA HRV08-ZIP

## Measurement and assembly

### 1. Measurement

The total width = centre of veranda profile to centre of veranda profile. The outside of the box is always 40 mm (2 x 20 mm) wider than the centre of the guide rails or the centre of the attachment supports.

The drop: measured from the back of the box at the top against the wall to the front of the guide rail, including the cover.

The final position of the extension pole can be set flush with the end of the cover of the guide rail.

Please note: the width of the box is always 40 mm more than the order width.

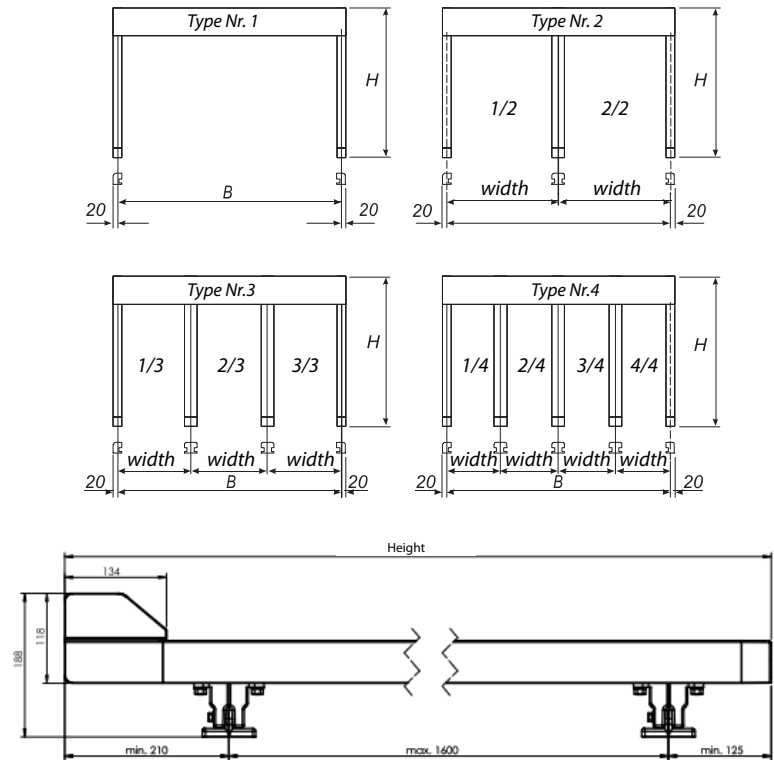
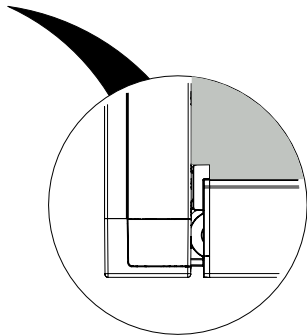
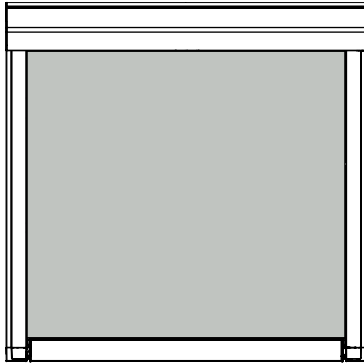

## Assembly

The HRV08-ZIP can be fitted in various ways. Here we will describe the various types of fitting. The choice of these types of fitting has an effect on such things as the technical possibilities, drainage holes and so on.

### Assembly MT1 – MT4

- Outdoor fitting
- Sunblind viewed along outside
- Fabric hangs outside
- Zipper at window side
- Drainage holes in extension pole and possibly in box
- Alu side of the fabric points to the sun for Soltis 86 and 92
- Grey film is on the window side for blackout fabric

#### ATTENTION:

In the case of fitting types 2 and 4, dirt can easily get into the box with the fabric. Additional periodic cleaning is required here.

Additional drainage holes are also provided in the box.

### Assembly MT5 – MT6

- Indoor fitting
- Sunblind viewed along inside
- Fabric hangs inside
- Zipper at window side
- No drainage holes in extension pole and box.
- Alu side of the fabric points to the floor for Soltis 86 and 92.
- Grey film is on the window side for blackout fabric.

### Assembly MT7 – MT8

- Outdoor fitting
- Viewed along outside
- Fabric hangs outside
- Zipper at window side
- Alu side of the fabric points to the sun for Soltis 86 or 92
- Grey film is on the window side for B-92 Blackout fabric

### Assembly MT9 – MT10

- Indoor fitting
- Viewed along inside
- Fabric hangs inside
- Zipper at window side
- Alu side of the fabric points to the floor for Soltis 86 and 92.
- Grey film is on the window side for B-92 Blackout fabric

#### Attention!

In the case of assembly type 7, 8, 9 and 10 dirt can get in the guide rail.

The motor is always at the top of the box.

To prevent damage to the lower side guide, We consider a placement for a sliding window unsuitable.

#### MT1

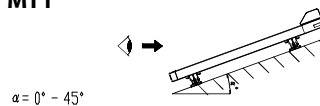

$\alpha = 0^\circ - 45^\circ$

#### MT2

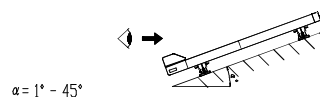

$\alpha = 1^\circ - 45^\circ$

#### MT3

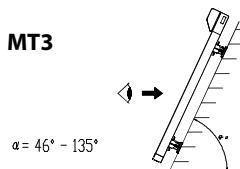

$\alpha = 46^\circ - 135^\circ$

#### MT4

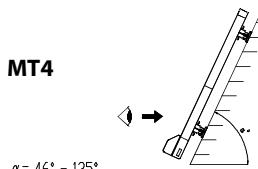

$\alpha = 46^\circ - 135^\circ$

#### MT5

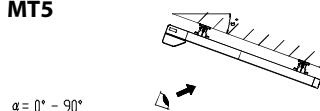

$\alpha = 0^\circ - 90^\circ$

#### MT6

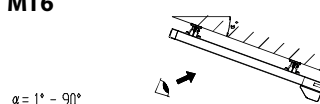

$\alpha = 1^\circ - 90^\circ$

#### MT7

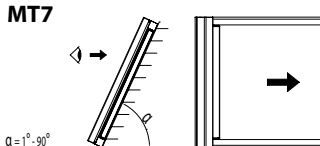

$\alpha = 1^\circ - 90^\circ$

#### MT8

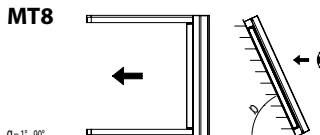

$\alpha = 1^\circ - 90^\circ$

#### MT9

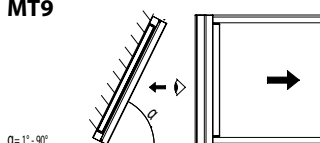

$\alpha = 1^\circ - 90^\circ$

#### MT10

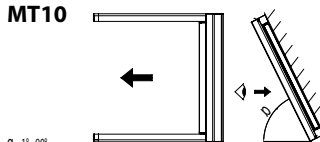

$\alpha = 1^\circ - 90^\circ$

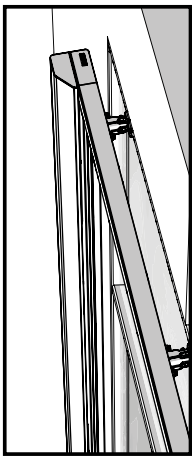

1

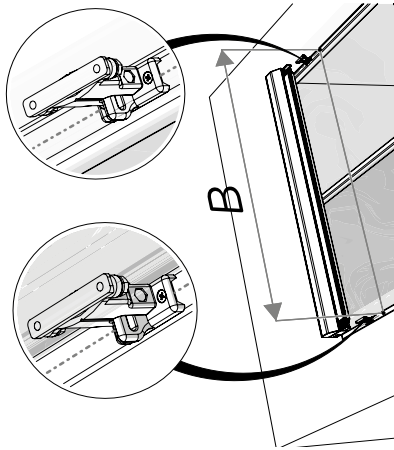
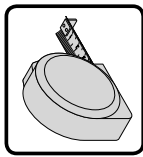

$$= B + (2 \times 20)$$

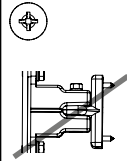
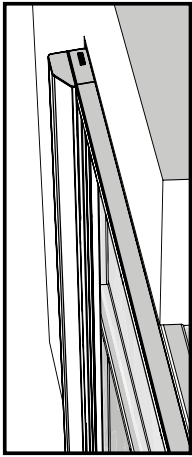

A 168



A 167



DIN 7981  
4,8 x 22 mm

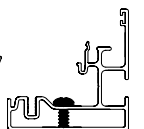
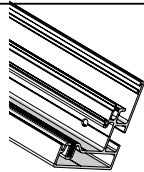
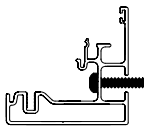
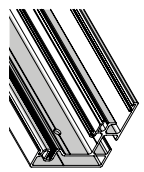

4

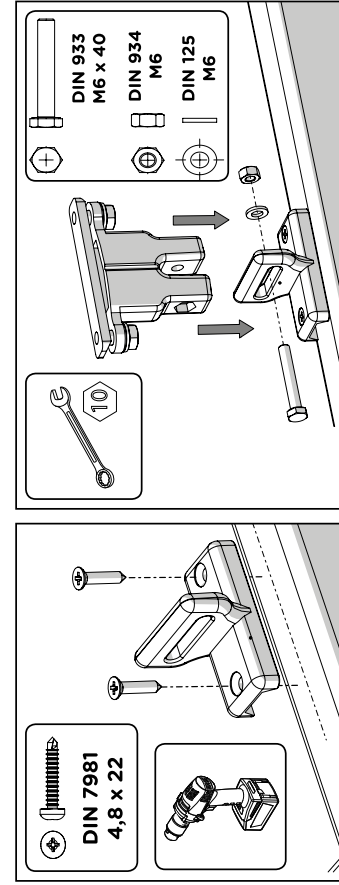
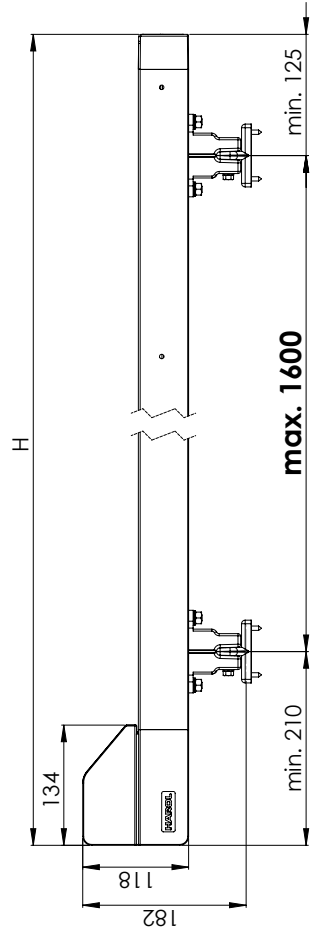

DIN 7981  
4,8 x 22



DIN 933  
M6 x 40  
DIN 934  
M6  
DIN 125  
M6

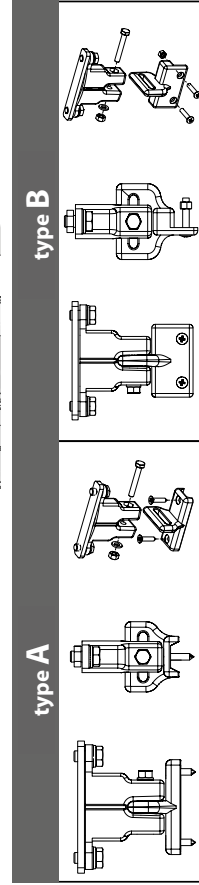
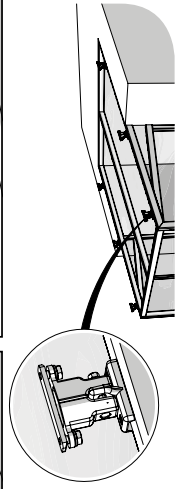

type A

type B

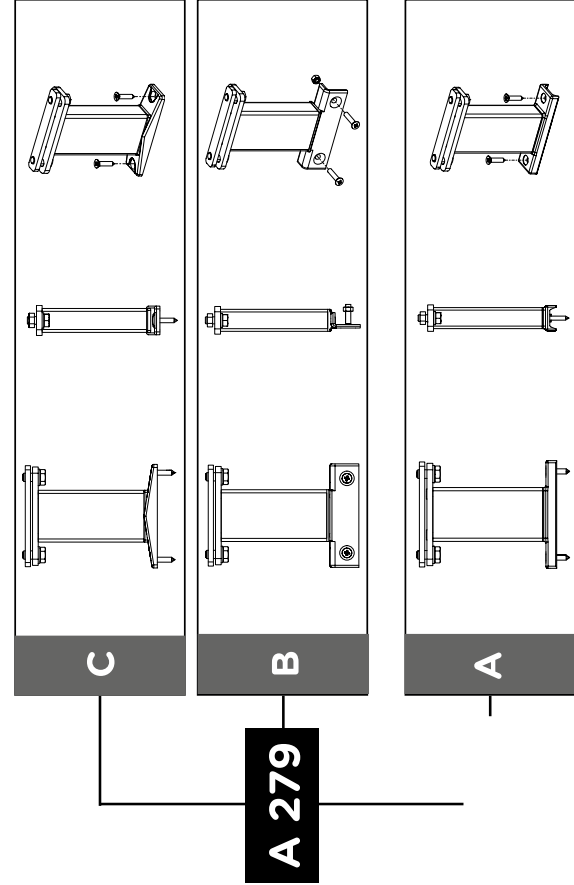

C

B

A

A 279

2

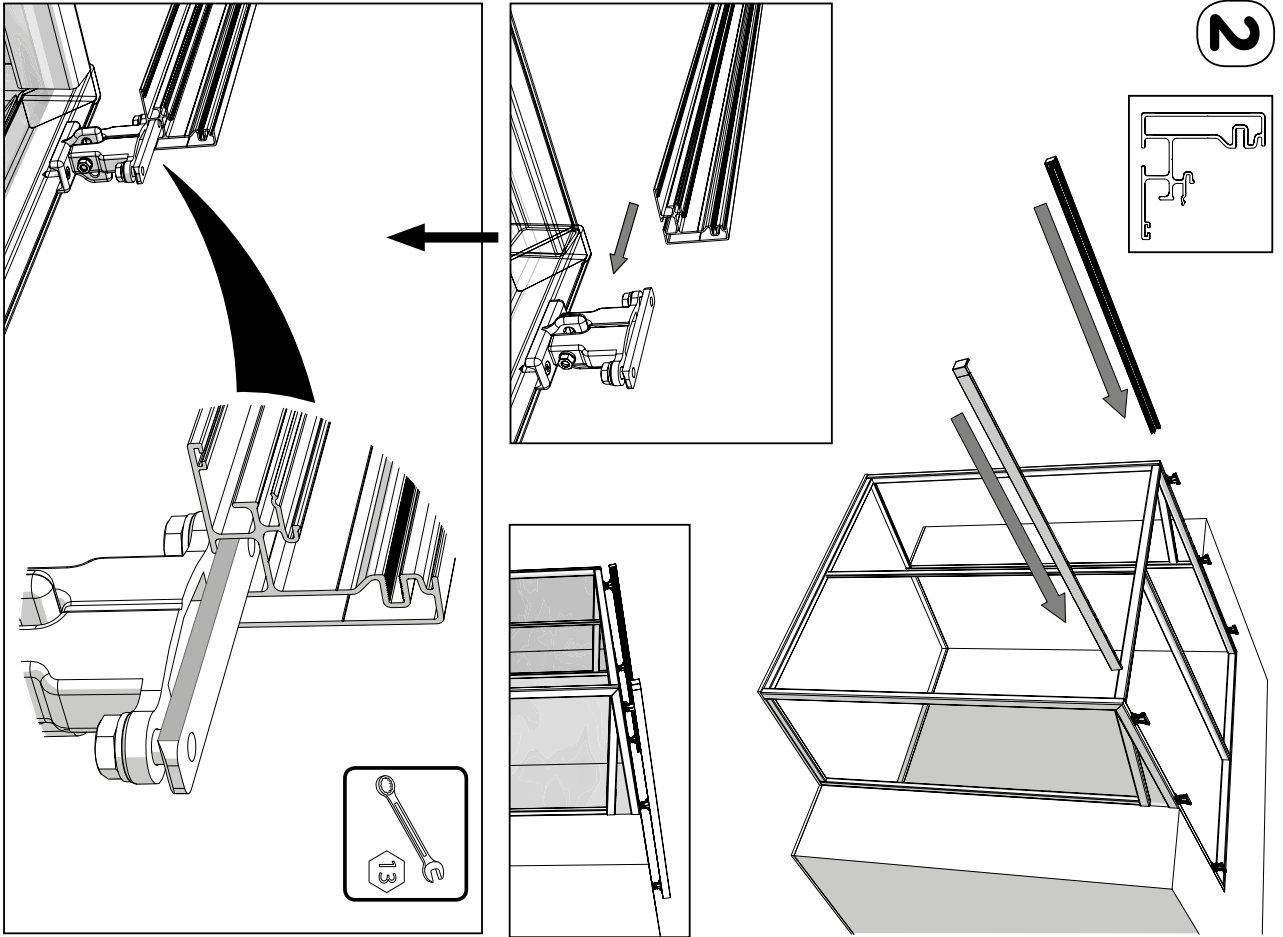

3

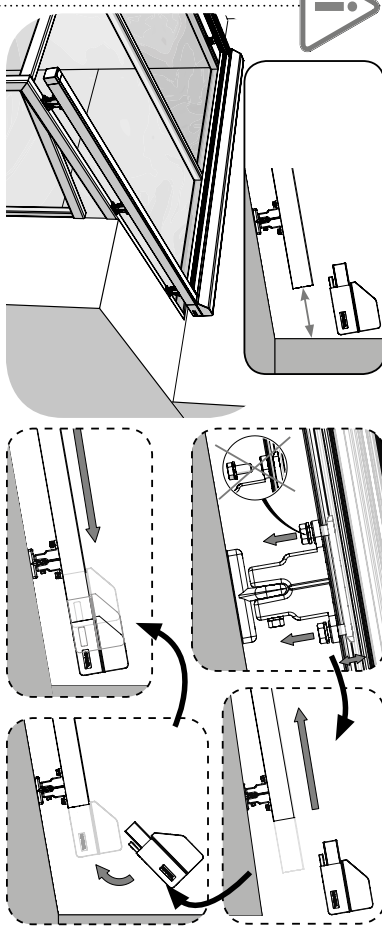
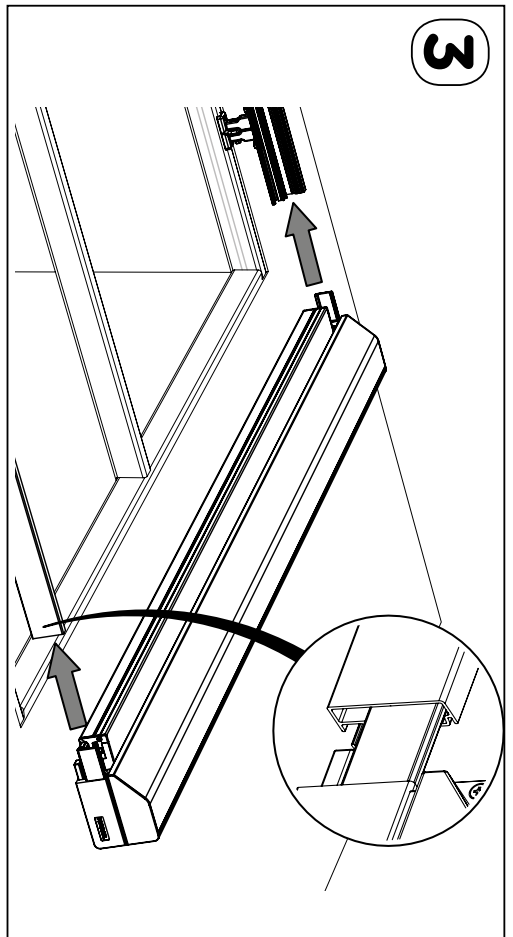

4

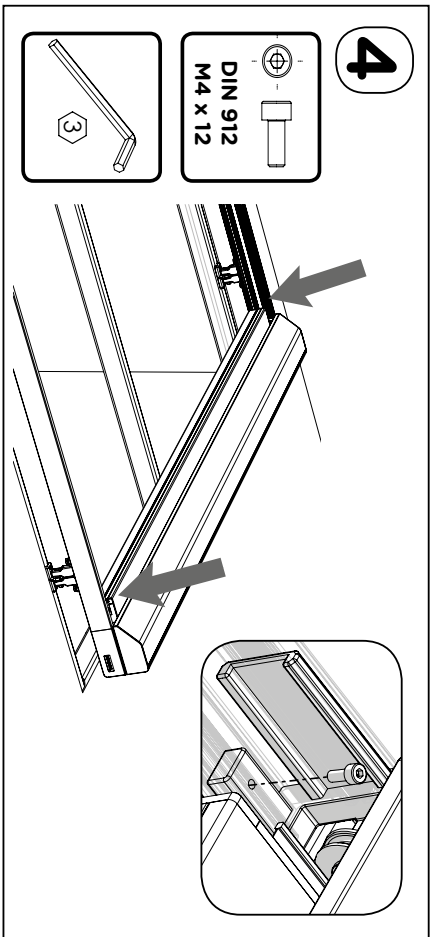

**5** CONTROL

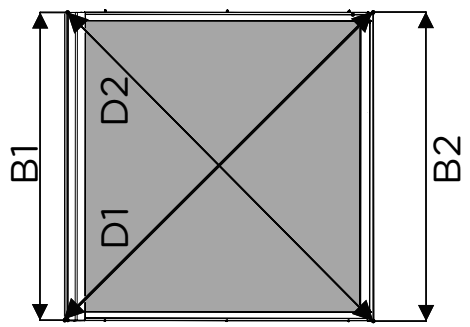
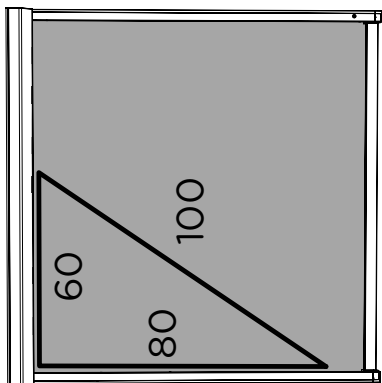

**B1 = B2 & D1 = D2**  
(+/- 2mm)

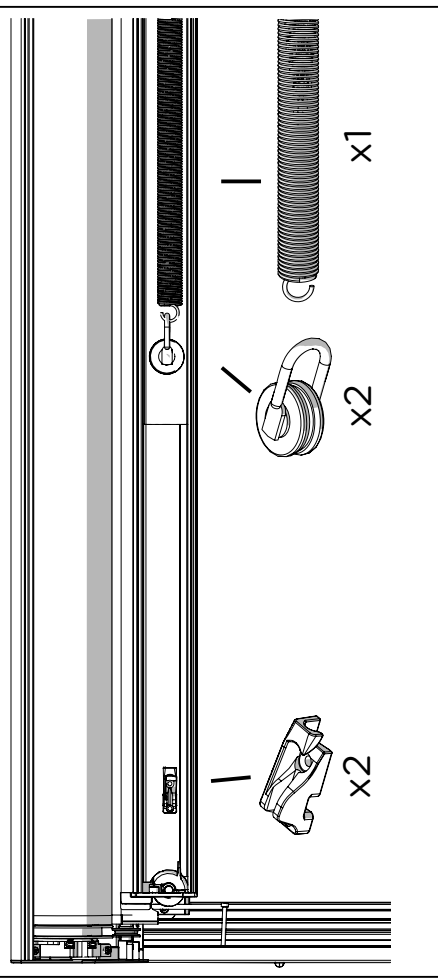
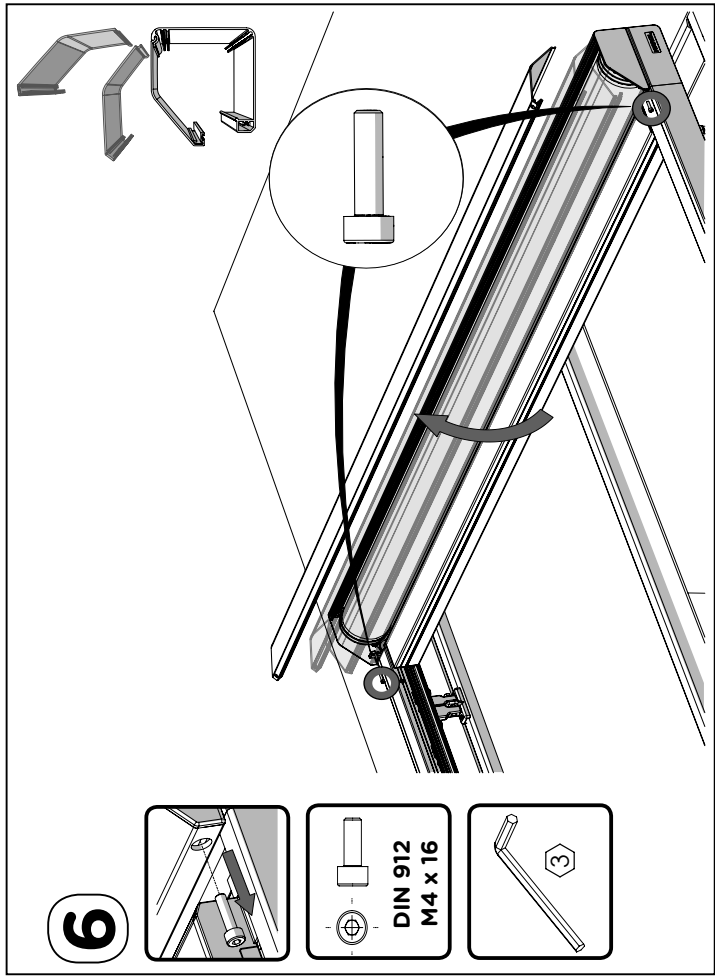
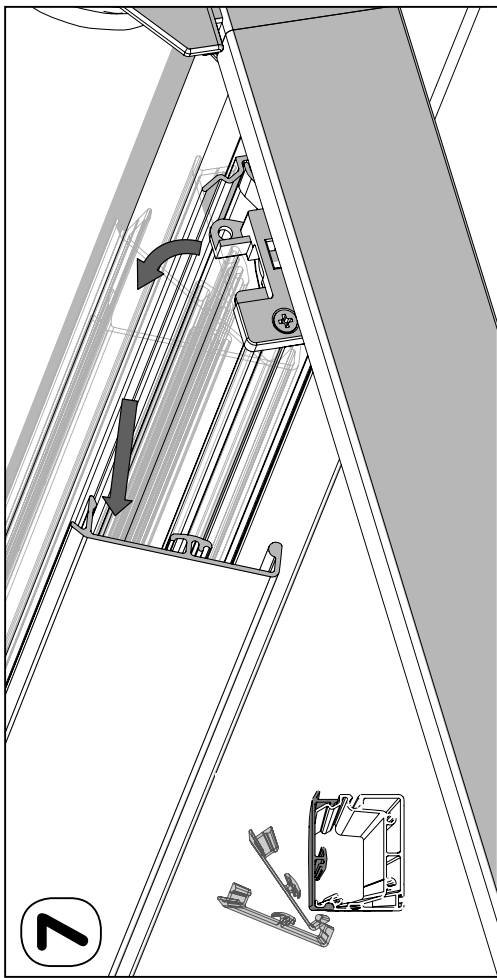

8

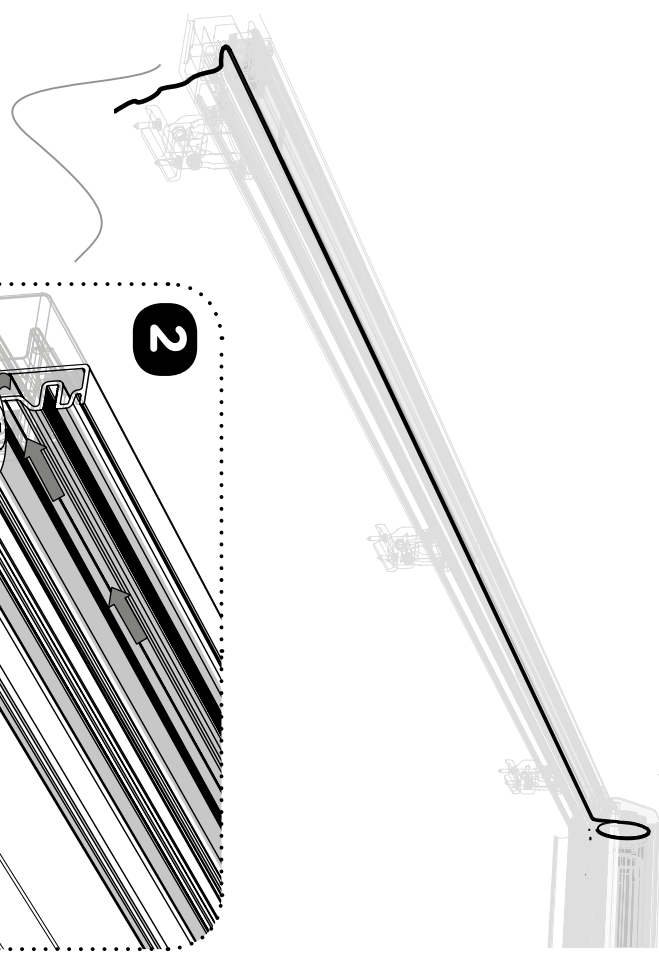
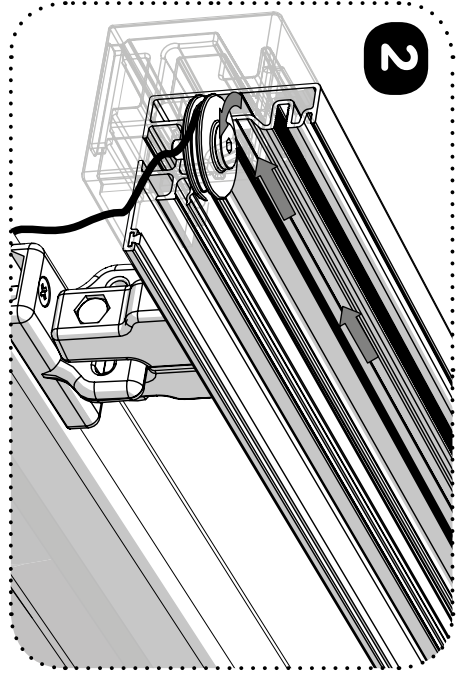
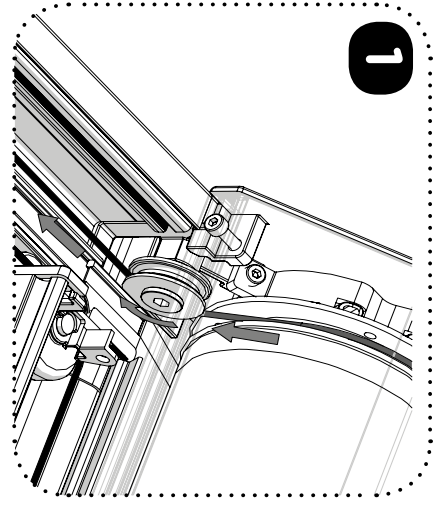
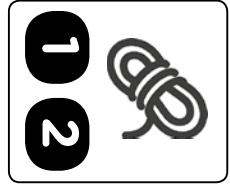

9

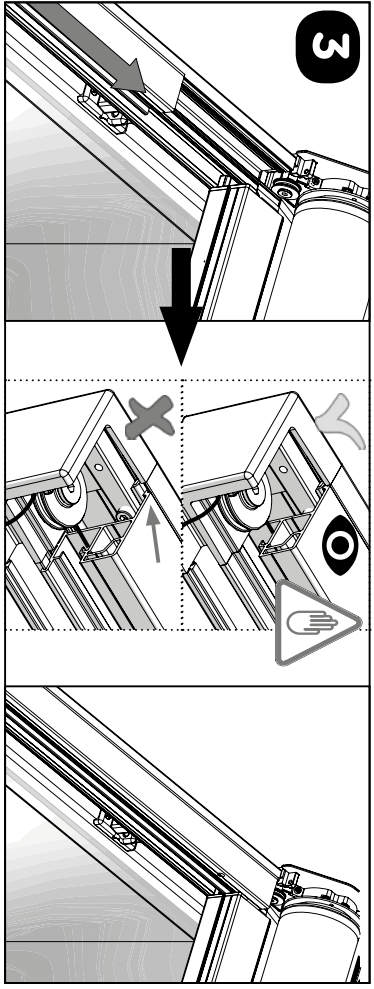
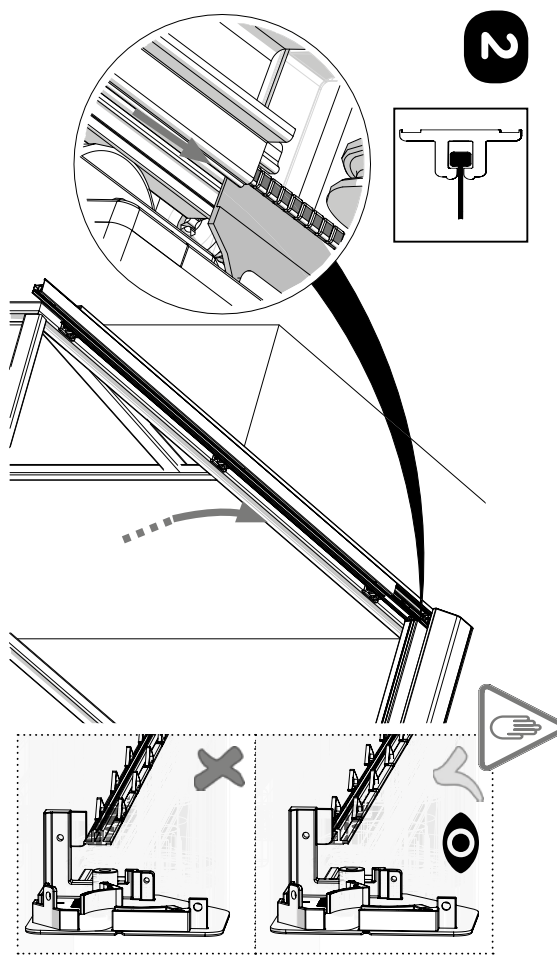

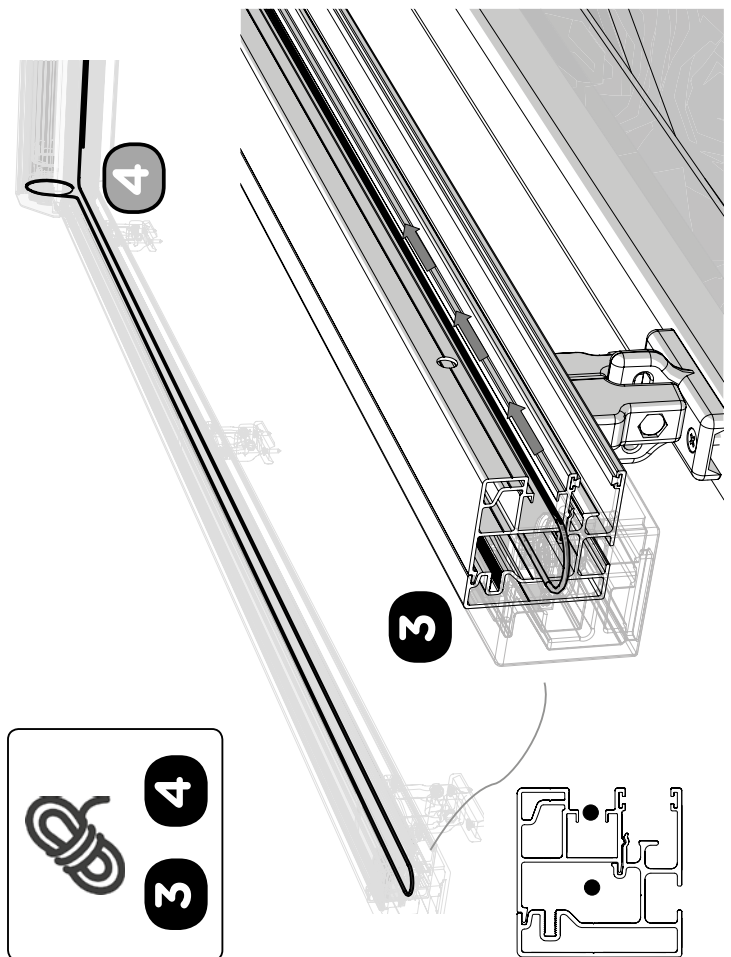
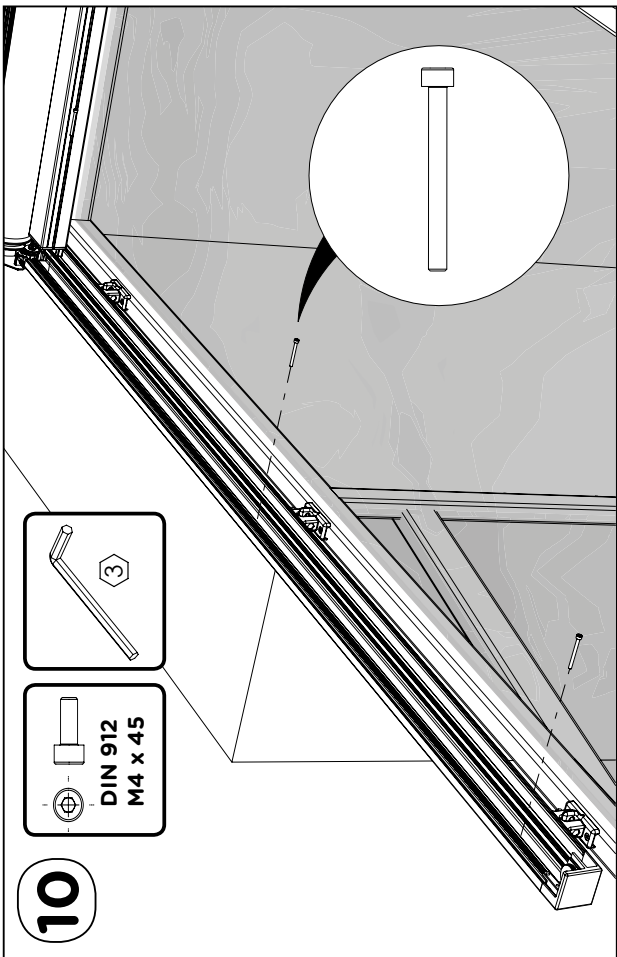
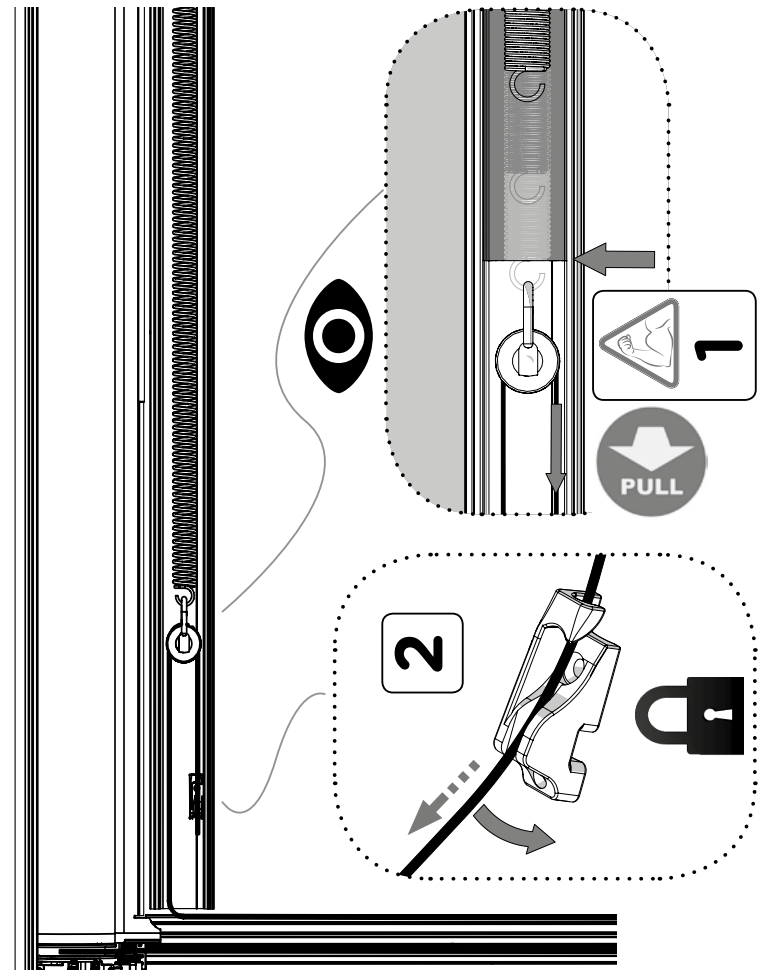
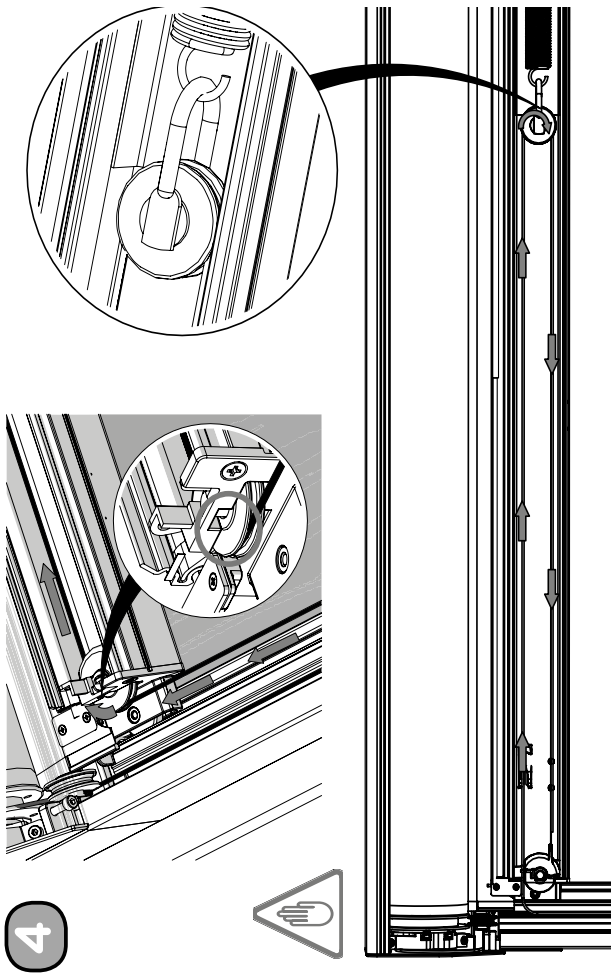

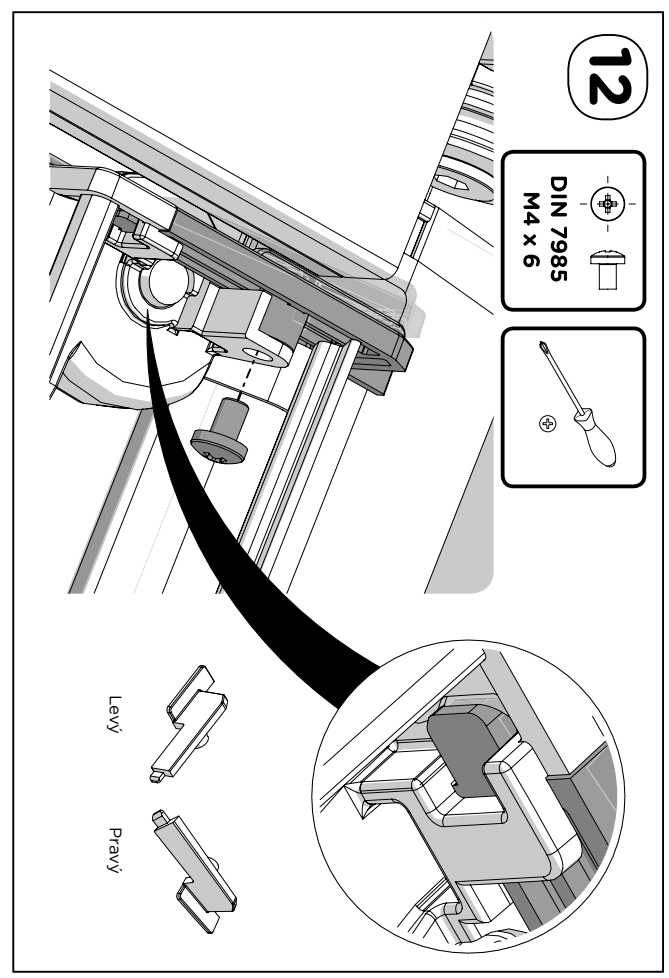
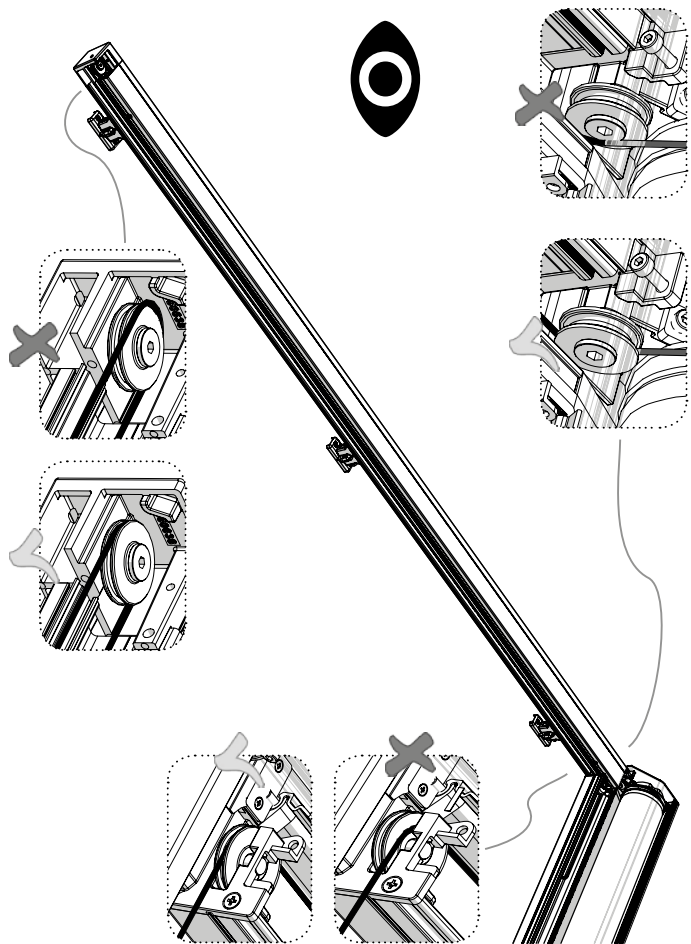

**12**

DIN 7985  
M4 x 6

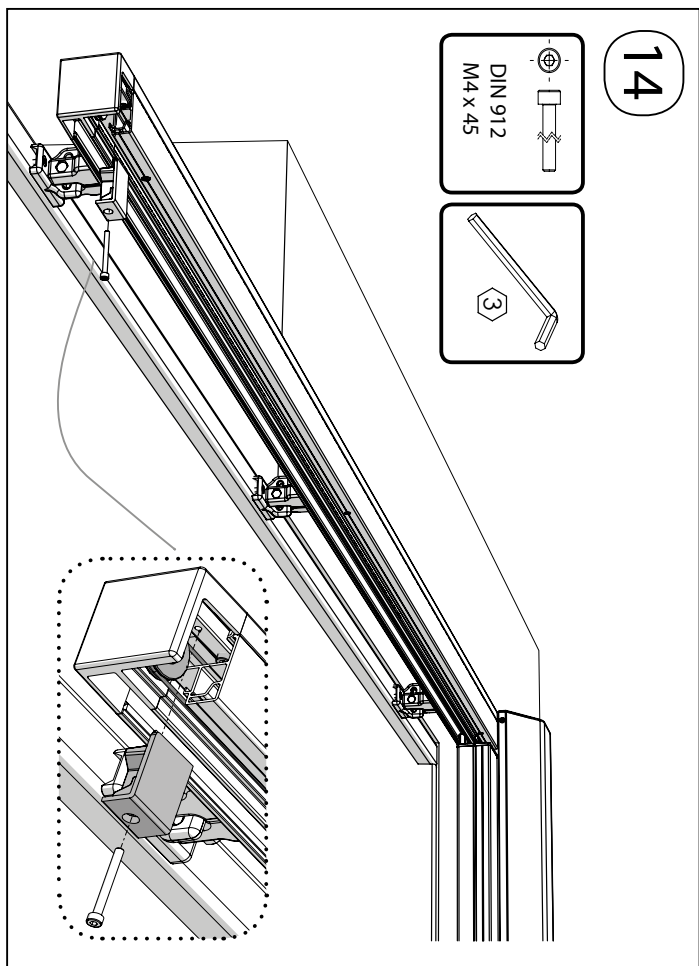

**14**

DIN 912  
M4 x 45

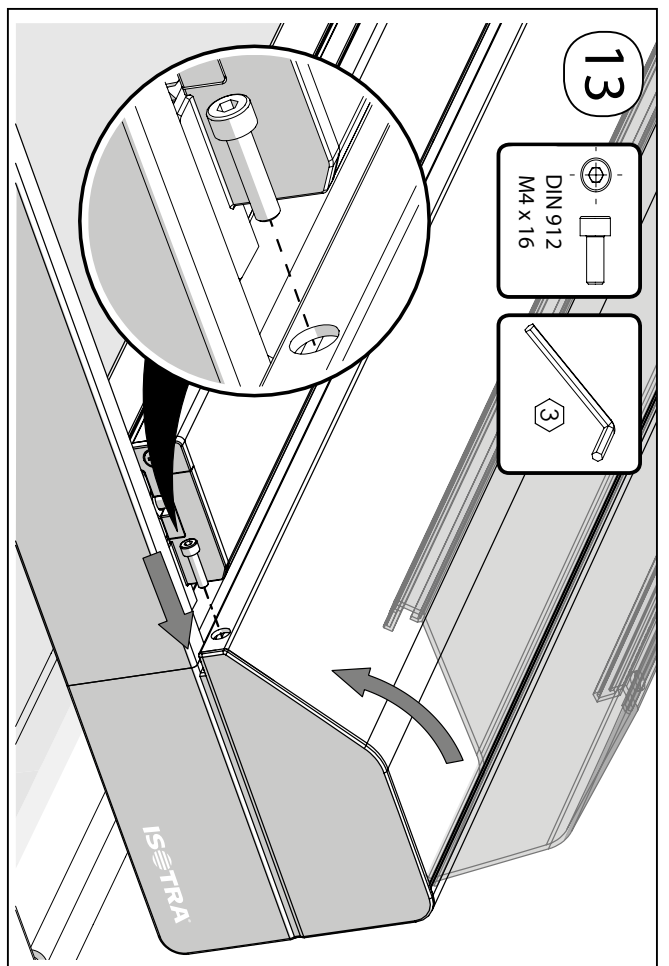

**13**

DIN 912  
M4 x 16

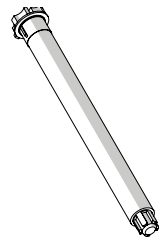

somfy.  
www.somfy.com



- OREA 50 WT 25/17
- OREA 50 WT 40/17
- Gemini 25/17 SLT50
- Mariner 40/17 SLT50
- Orea 25/17 LT50 RTS
- Orea 40/17 LT50 RTS
- Sunea 50 IO 25/17
- Sunea 50 IO 40/17

see instruction manual Somfy



15  
↑ ↓  
x1

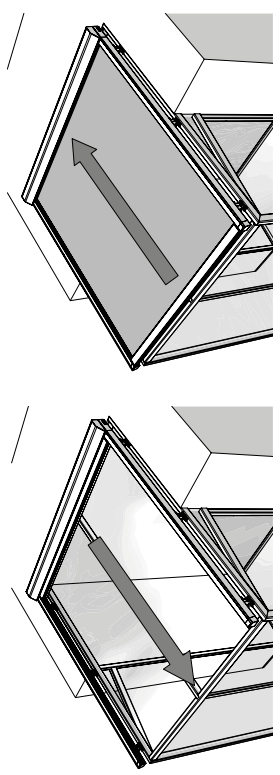

16

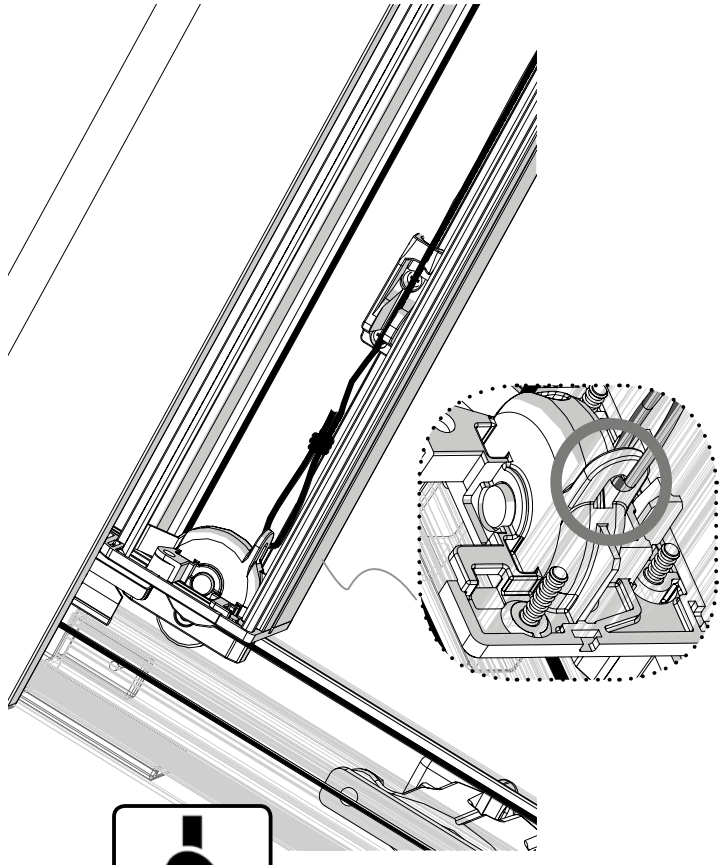
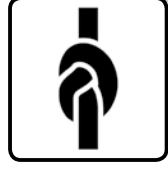

17

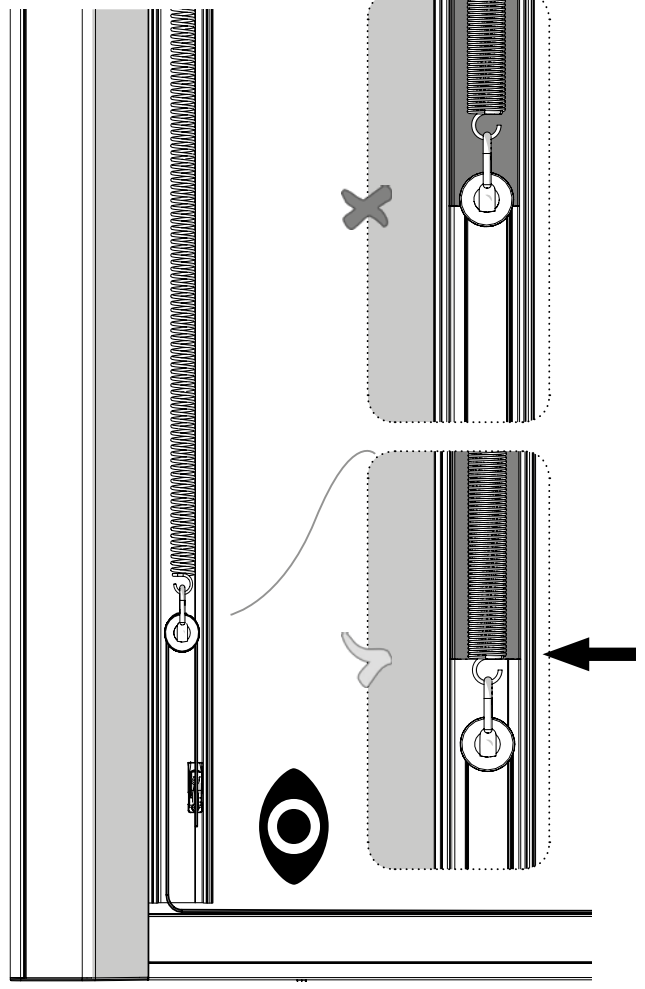
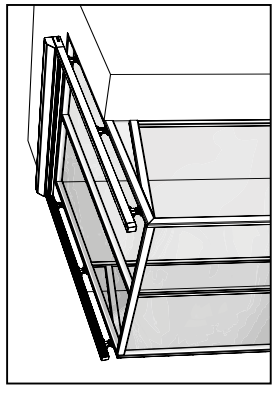
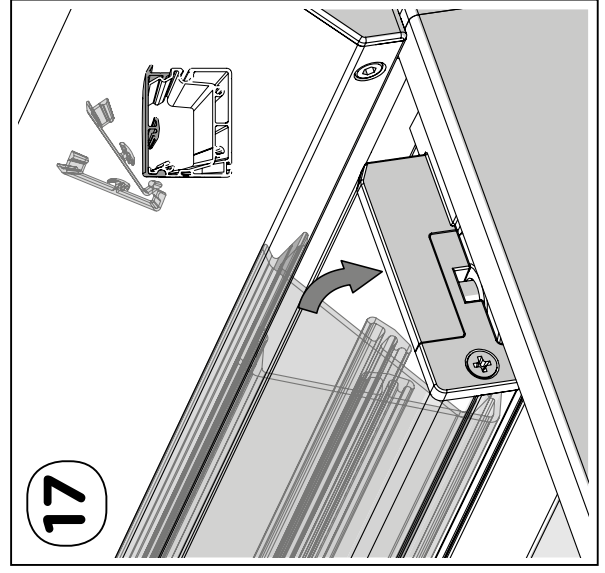

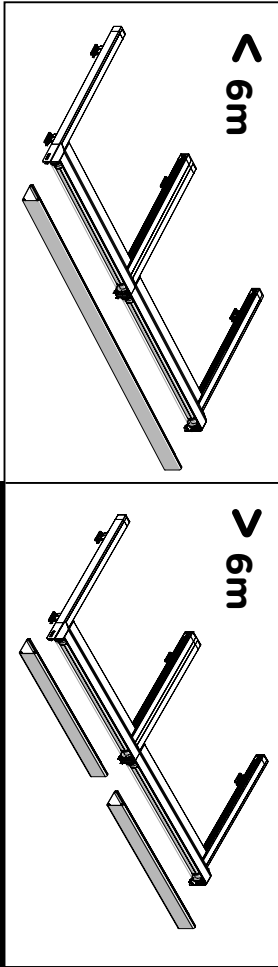
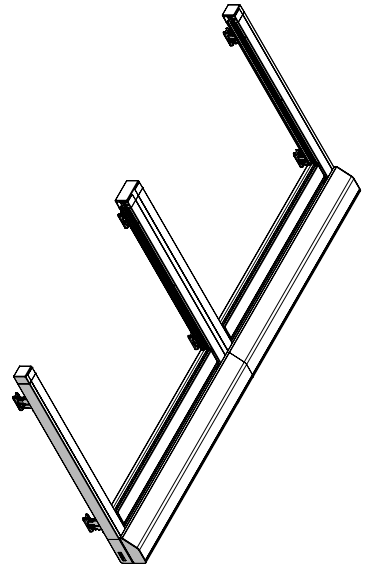

**1** see page 32

**2** + see page 34

**+** extra assembly steps

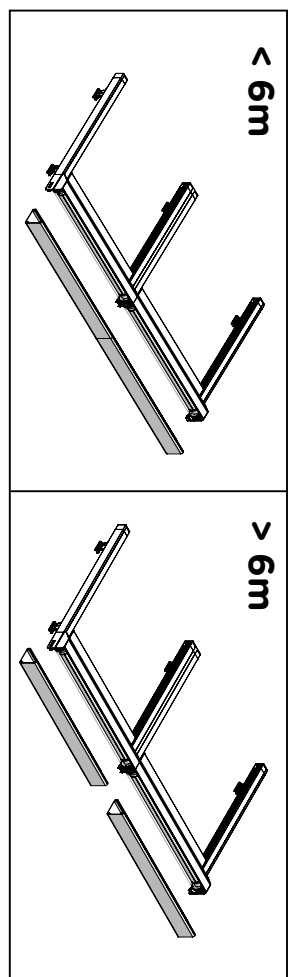
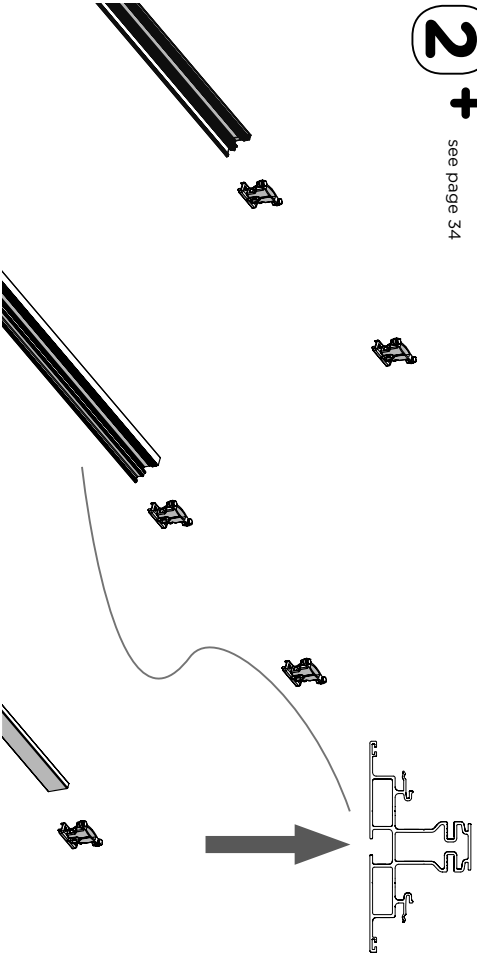

**3** + see page 35

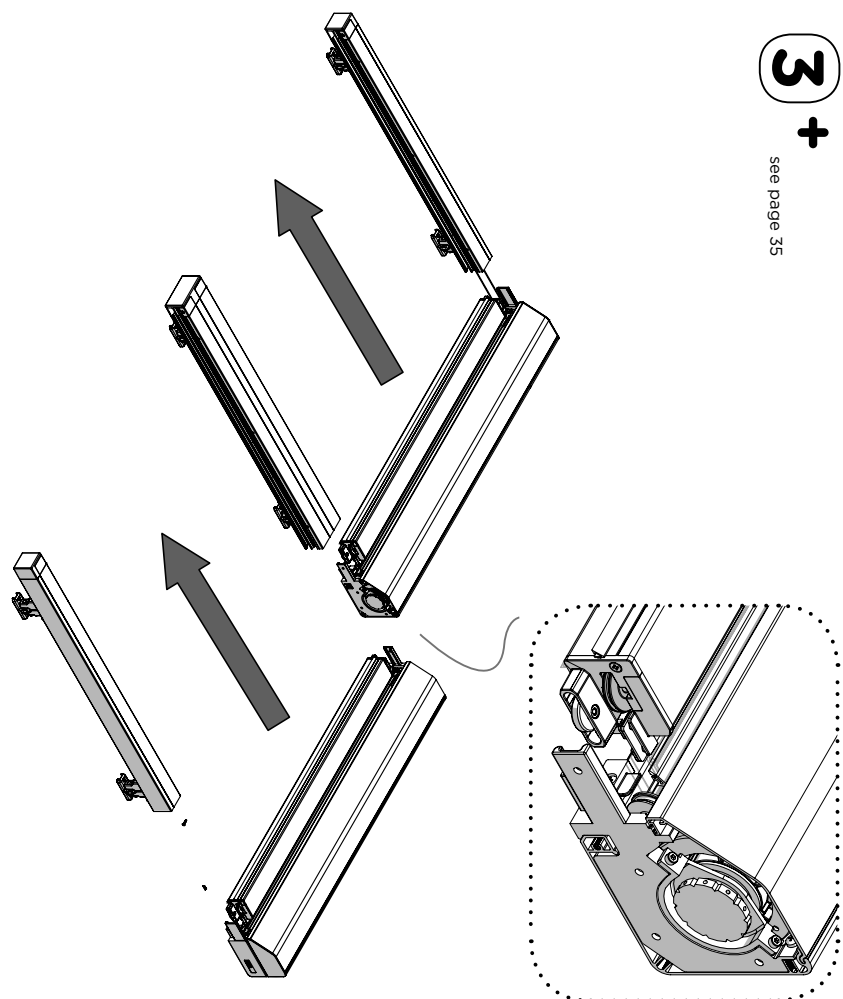

**4** **5**

**6** +

see page 36

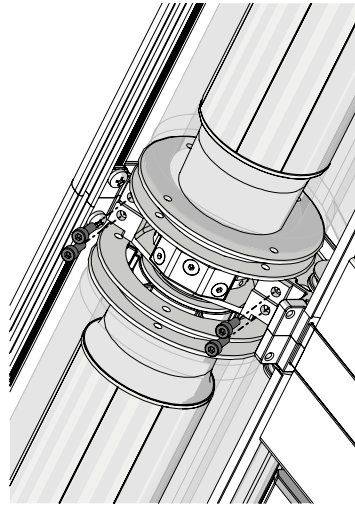
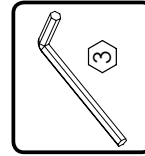
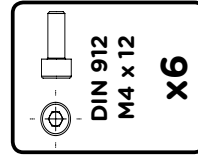
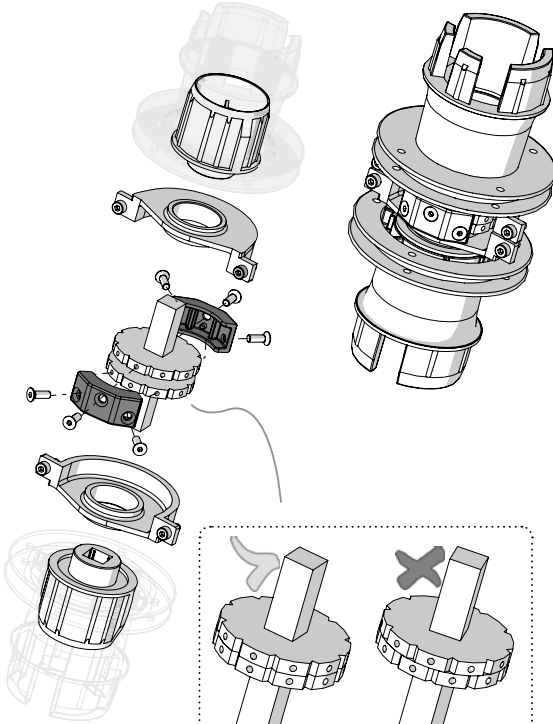
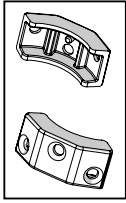
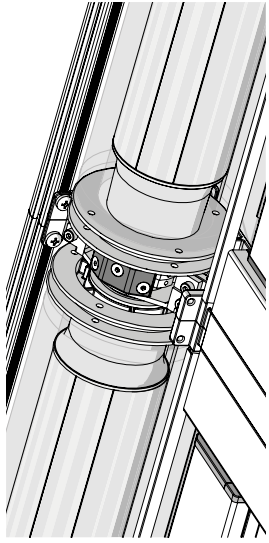
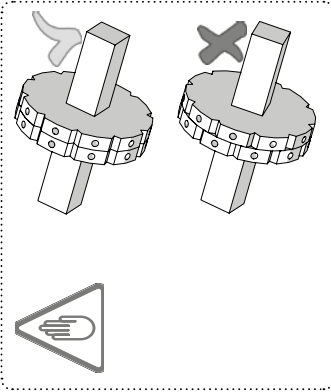
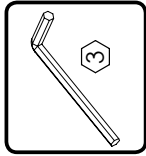
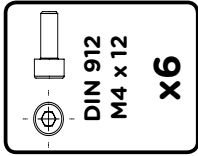

**7**

**8**

.....



**17**

## Veranda HRV80-ZIP

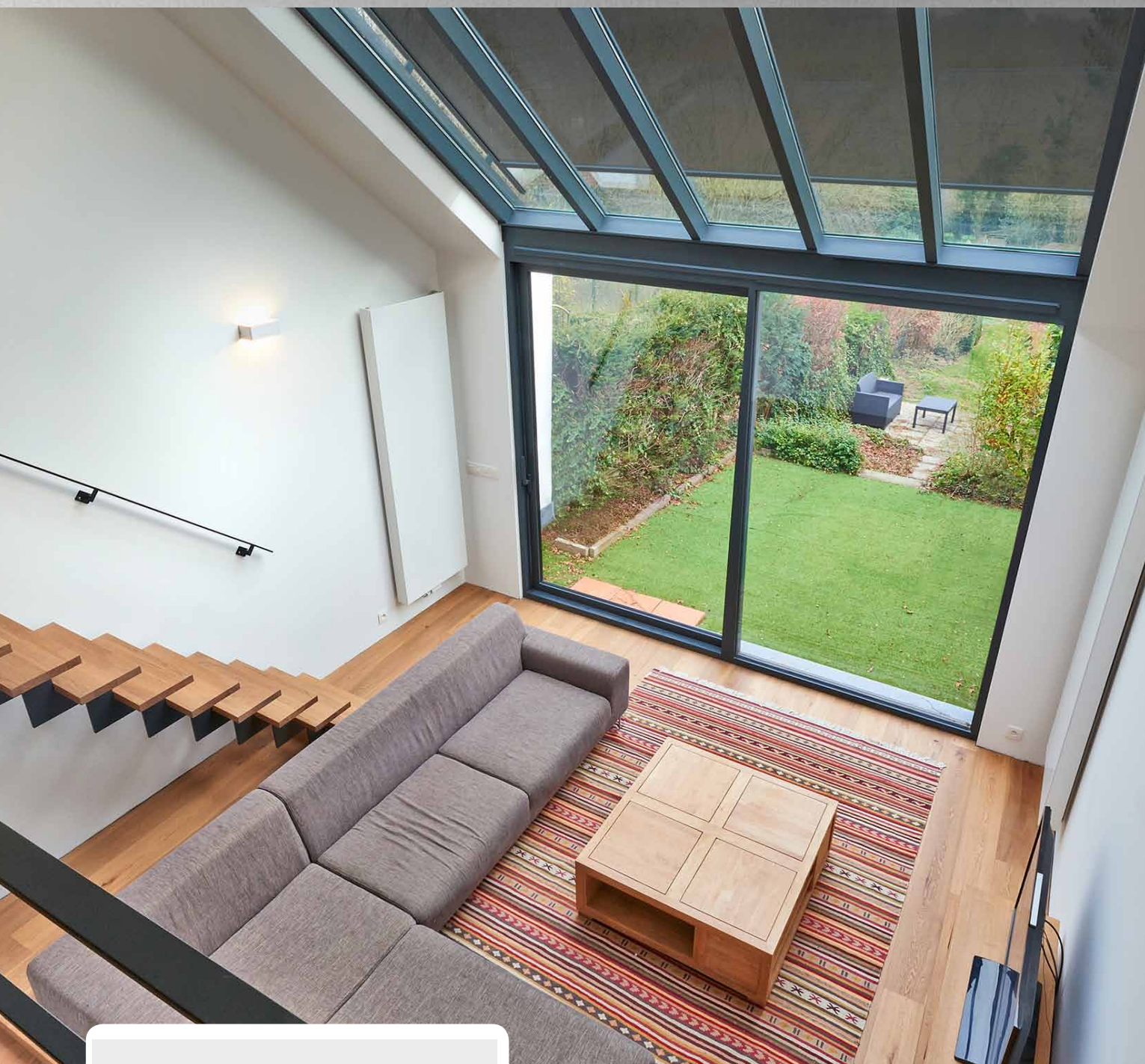

- ▲ Ideal for large glazed areas up to the 25 m<sup>2</sup> size in a single frame
- ▲ Less sunlight on vertical glazed areas thanks to an overlap
- ▲ Compact box: 245 (W) × 175 (H)
- ▲ Taut fabric thanks to the ZIP system

**ISOTRA** *Quality*

# VERANDA HRV80-ZIP

## Basic product specification

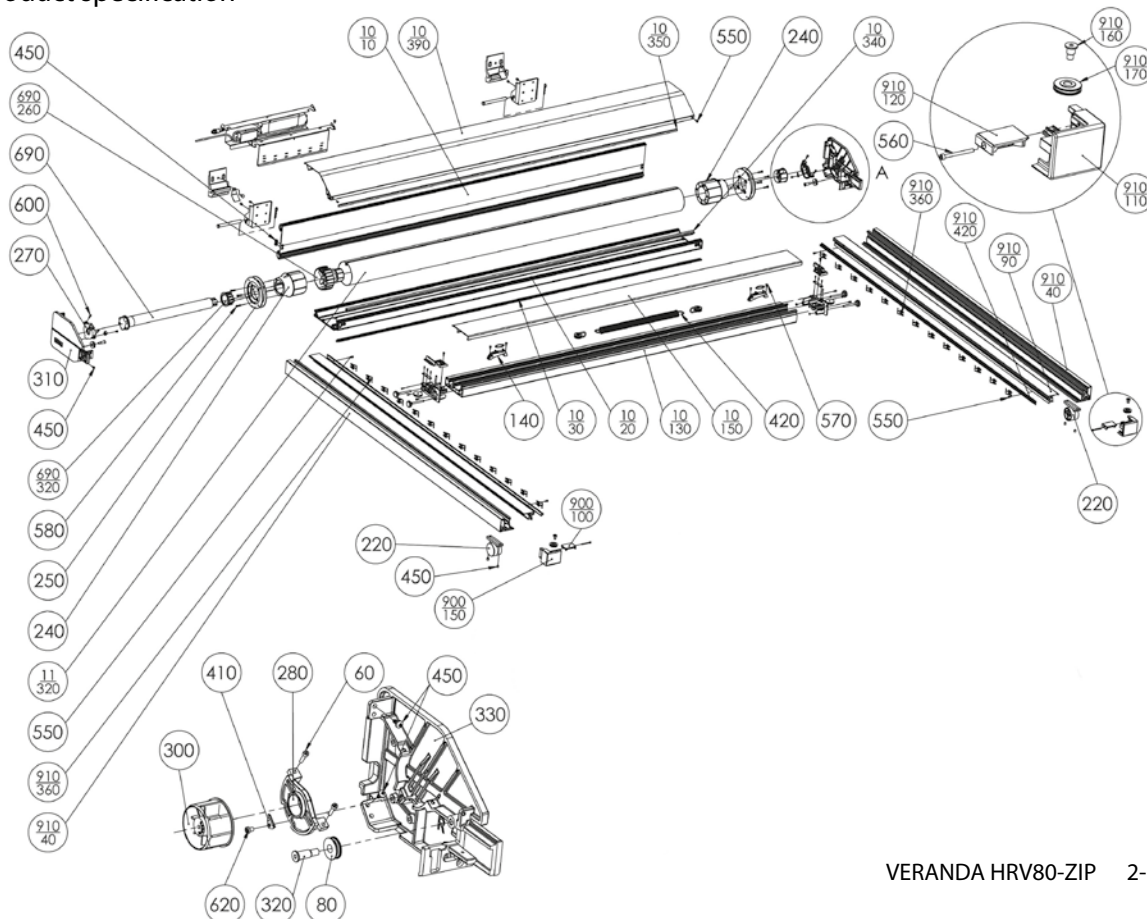

VERANDA HRV80-ZIP 2-01532-0000

### Controls

Serves for opening and retracting the veranda. All box sizes can only be controlled by motor.

**Motor** – tubular motor 230 V (50 Hz) located on the far left or far right, as necessary. The standard supply includes a 3-metre cable (optionally 5, 10 m), Sunea IO motor type without push buttons, being controlled by an IO transmitter (can also be without the wall-mounted IO transmitter). Optionally, it is possible to supply the Orea WT motor with automatic readjustment, or the Orea RTS motor with built-in RTS receiver.

The controls are always located when viewed from the outside.

### Fabrics

The fabrics are welded horizontally.

#### Fabrics of the Blackout type:

The opaque layer is located on the side of the window for each type of installation. In the case of outdoor installation, strong winds can cause a slight lifting of the base slat and fabric and therefore 100% blackout cannot always be guaranteed. In the case of Blackout fabrics, the zippers are fastened on the face side and not on the opaque layer, so it is possible that under strong wind or oblique view of the guide rail a piece of cloth from the zipper tape can be seen, but this is of little importance compared to tightness of the fabric (reducing the waves).

### Specifications

	Upper section	Bottom section	Lateral guiding		Support profile
			Guide rail		
<b>Dimensions (mm)</b>	245 x 175	140 x 63	76,5 x 65	133 x 65	
<b>Material</b>	Al <sub>140</sub>	Al <sub>140</sub>	Al <sub>76,5</sub>	Al <sub>133</sub>	
<b>Colour</b>	RAL 9010, RAL 9006, RAL 9007, RAL 8014, RAL 7016, RAL 7016S, DECORAL only up to the max. width of 4000 mm				

### Standard dimensions

Version	Width (mm)		Height (mm)	Guaranteed area (m <sup>2</sup> )
	min	max	max	max
motor	1500	6000*	6000	25

\*For fabrics SLTZB 92 is max. width 5000 mm.

**VERANDA HRV80-ZIP (2-01532-0000)**

<b>position</b>	<b>item name</b>	<b>trade name - abbreviation 2</b>	<b>order number - abbreviation 1</b>
<b>10</b>	<b>Multi-piece sections – VERANDA</b>		<b>see Multi-piece sections – VERANDA HRV80-ZIP</b>
11/230	Winding cylinder, diameter 110×1.25 mm	VRH 166	6-015978-0000
80	Reversing wheel for side board – 28×8 mm	VRH 094	6-014597-0000
140	Terminal board for HI-TEC cord complete	VRH 099	6-014607-0000
220	Suspension 65×65 part 2	VRH 165	6-015977-0000
240	Cylinder cap, diameter 110 mm – BLACK	VRH 167	6-015979-0000
250	Cord coiler, diameter 110 mm – BLACK	VRH 168	6-015980-0000
270	Cord coiler, diameter 110 mm – BLACK	VRH 174	6-015999-9004
280	Movable holder – BLACK	VRH 175	6-016000-9004
300	Cylinder cap, square – BLACK	VRH 176	6-016001-9004
310	Side board – LEFT	VRH 177	6-016002-9004
320	Reversing wheel pin – 10×34 mm	VRH 014	6-014598-0000
330	Side board – RIGHT	VRH 178	6-016003-0000
370	Lower section end piece – LEFT – BLACK	VRH 179	6-016004-9004
380	Wheel with fork for cord guiding HRV		6-019123-0000
400	HI-TEC cord 2.7 mm	VRH 021	6-014626-0000
410	Console lock	VRH 182	6-016008-0000
430	Screw 3.5×16 DIN 7982 C-H A2, countersink – cross-head	VRH 130	6-014674-0000
440	Screw 2.9×13 DIN 7982 C-H A2, countersink – cross-head	VRH 129	6-014738-0000
450	Screw 4.8×13 DIN 7982 C-H A2, countersink – cross-head	VRH 134	6-014734-0000
460	Allen head screw M6×30, DIN 912, A2		6-010408-0000
500	Screw M5×16 Zn DIN 965-Z, A2, countersink – cross-head		6-014338-0000
550	Allen head screw M4×25, DIN 912, A2		6-016048-0000
570	Screw 4.2×13 DIN 7981 CH, A2, cup-head, cross-head	VRH 132	6-014640-0000
580	Screw – WN 1412 – K50×25, A2		6-016013-0000
600	Allen head screw M4×16, DIN 912, A2	VRH 102	6-014736-0000
620	Screw M4×6 INOX A2, DIN 7985-H, cup-head, cross-head	VRH 105	6-014737-0000
<b>690</b>	<b>Motors (SOMFY) VERANDA</b>		<b>see Motors – VERANDA HRV80-ZIP</b>
800	Screw M5×10 INOX A2, DIN 933 (hexagonal)		6-012977-0000
<b>900</b>	<b>Guiding – rail – LEFT</b>		<b>see Guiding – rail – LEFT</b>
<b>910</b>	<b>Guiding – rail – RIGHT</b>		<b>see Guiding – rail – RIGHT</b>

**Multi-piece sections – VERANDA HRV80-ZIP (3-03390-0085)**

<b>position</b>	<b>item name</b>	<b>trade name - abbreviation 2</b>	<b>order number - abbreviation 1</b>
10/10	Section BOX – rear	VRH 147	6-015958-0000
10/20	Section BOX – lower	VRH 148	6-015959-0000
10/30	Lower section LED – 7.0m	VRH 149/1	6-015960-0007
10/130	Lower section	VRH 158	6-015969-0000
10/150	Lower section – cover	VRH 159	6-015970-0000
10/340	Profile for fabric run-on	ZPH115-1	6-013986-0000
10/350	Brush for upper box – BLACK	VRH 024	6-014706-9004
10/390	Section BOX – cover	VRH 181	6-016007-0000

**Guiding – rail HRV80-ZIP – LEFT (2-01533-PU11L)**

position	item name	trade name - abbreviation 2	order number - abbreviation 1
900/100	Guide rail cap – left	VRH 155	6-015966-0000
900/150	Guide rail end piece – left	VRH 151	6-015962-0000

**Guiding – rail HRV80-ZIP – RIGHT (2-01533-PU11P)**

position	item name	trade name - abbreviation 2	order number - abbreviation 1
910/40	Guide rail section	VRH 150	6-015961-0000
910/90	Guide rail section – lock	VRH 154	6-015965-0000
910/110	Guide rail end piece – right	VRH 156	6-015967-0000
910/120	Guide rail cap – right	VRH 157	6-015968-0000
910/160	PIN of side board dia. 10	VRH 152	6-015963-0000
910/170	Wheel for rope	VRH 153	6-015964-0000
910/360	Spring of guide rail ZIP SC800	ZPH147	6-013992-0000
910/420	Guiding section SC800 for zip v3	ZPH145	6-014155-0000

**Motors – VERANDA HRV80-ZIP (2-00530-0008)**

position	item name	trade name - abbreviation 2	order number - abbreviation 1
310	Carrier LT50/60 HI – dia. 110 mm	VRH 170	6-015982-0000
320	Adapter – LT50 – tube dia. 61 mm	VRH 003/1	6-014898-0000

**Weight**

box		2 lateral guides		double guide rail	
length	weight	length	weight	length	weight
1,0m	approx. 25 kg	1,0m	approx. 5 kg	1,0m	approx. 4 kg
1,5m	approx. 35 kg	2,0m	approx. 10 kg	2,0m	approx. 8 kg
2,0m	approx. 45 kg	3,0m	approx. 15 kg	3,0m	approx. 12 kg
2,5m	approx. 55 kg	4,0m	approx. 20 kg	4,0m	approx. 16 kg
		5,0m	approx. 25 kg	5,0m	approx. 20 kg
		6,0m	approx. 30 kg	6,0m	approx. 24 kg

Veranda HRV80-ZIP, having the width of 2.5 metres and height of 2 metres, weighs approx. 65 kg.

## Veranda HRV80-ZIP

### Basic product specification

#### Section BOX

Material: extruded aluminium, powder-coated.

Wall thickness: 2.5 mm.

Dimensions: 245 mm x 175 mm

Consists of two parts:

- removable tapered upper section or cover,
- fixed bottom section.

The fabric guiding section is attached to the fixed section that leads the fabric from the box.

The cover includes a built-in brush.

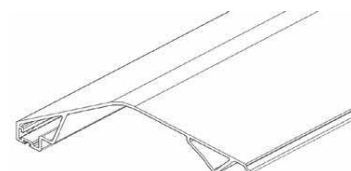
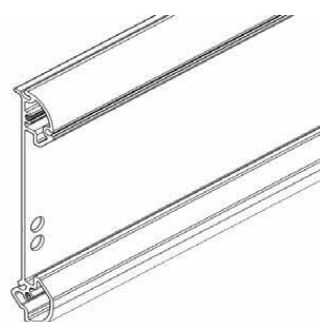
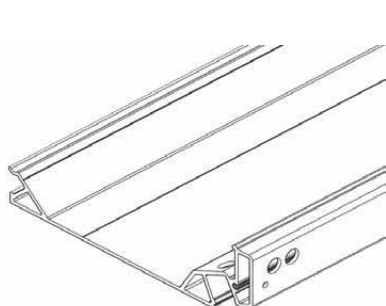
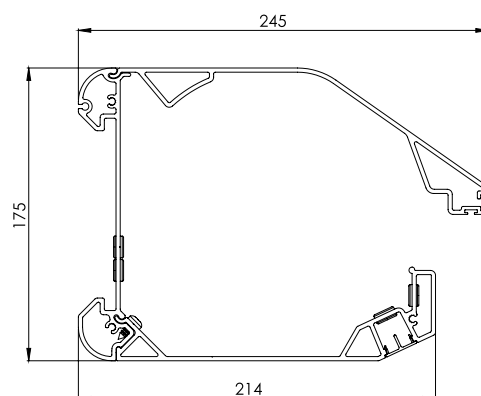

**Section BOX – bottom**

**Section BOX – rear**

**Section BOX – cover**

#### Bottom section

Material: extruded aluminium, powder-coated.

Wall thickness: basic section 4 mm.

Closing section 2 mm.

Function:

- The basic section is equipped with a groove, into which fabric can be attached.
- The closing section is fitted on the basic section.
- It moves in the lateral guide grooves on special sliding blocks.

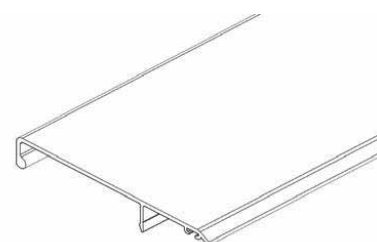
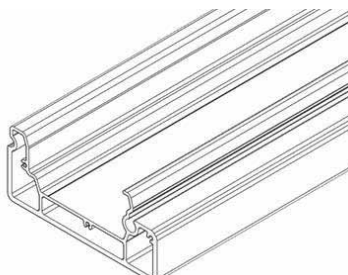
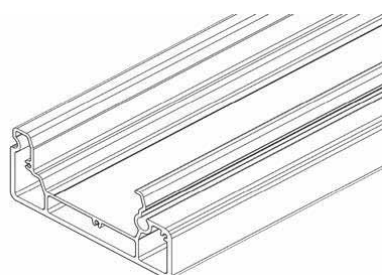
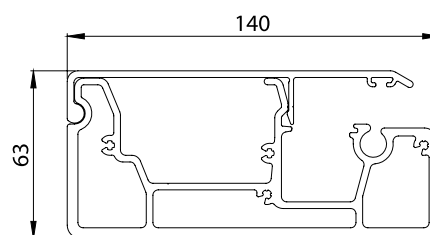

**Bottom section up to 4 m**

**Bottom section over 4 m**

**Bottom section – cover**

### Winding cylinder

Material: galvanised-steel tube with a groove for attaching the fabric.

Function: unwinding and winding of the fabric

Up to the width of 4000 mm – the shaft diameter is 85 mm

From the width of 4001 mm – the shaft diameter is 110 mm

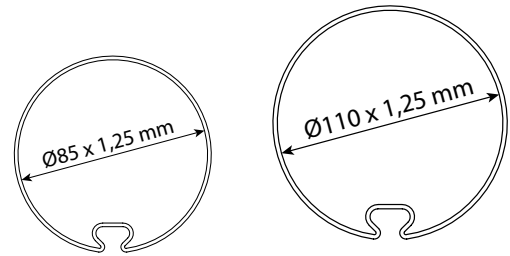

### Guide rails

Material: extruded aluminium, powder-coated

Wall thickness: 1.5 mm

Two types:

- Lateral guides: installed on the outside, with a groove on one side only.
- Connecting rails: installed in the middle, with grooves on both sides.

The sections have recesses, into which the lateral cover support pins fit.

The aluminium end covers have the same colour as the frame.

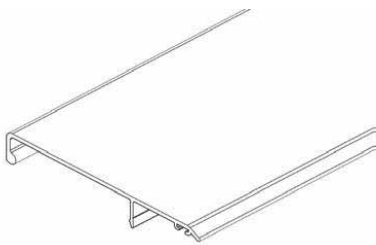
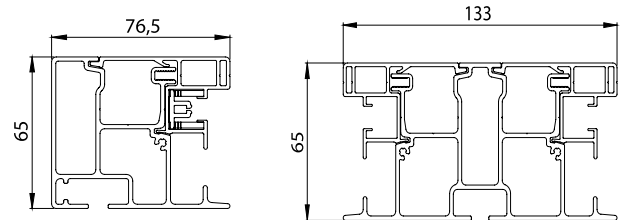

Guide rail section

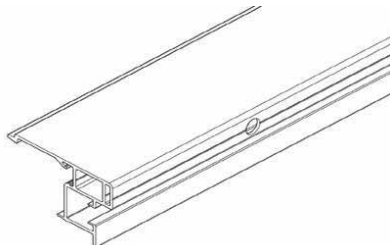

Guide rail section – closing

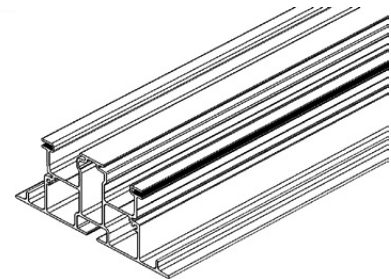

Guide rail section – double

### Zipper-type guide section

Material: extruded PVC clip section.

Function: Absorption of the zipper section on the fabric, making it taut using stainless springs.

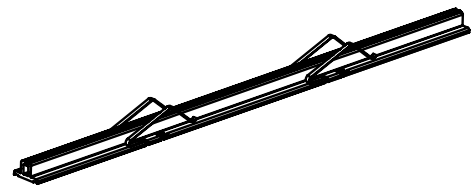

### Clip-On/Clip-Off section

Material: extruded PVC clamps.

Function: Attaching the fabric in the groove without the need to use screws, so that the fabric could be removed moving it to the front instead of pushing it sideways.

Clamp diameter: 3 mm.

Advantage: fast and easy fabric replacement

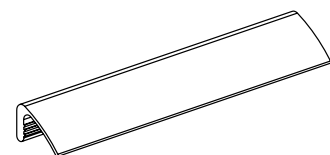

### Side board

Material: cast aluminium, powder-coated.

Colour: same as the frame colour

Dimensions: 214 × 175 mm

There are two types of brackets: side and connecting

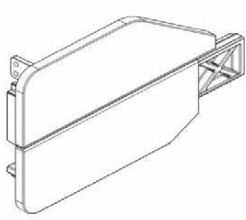
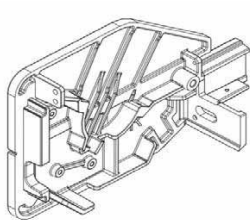

**Side board LEFT / RIGHT**

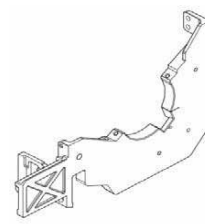
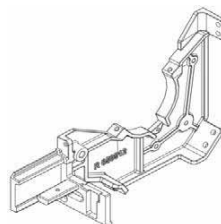

**Central side board – LEFT / RIGHT**

### Sliding blocks

Material: injection-moulded plastic

Function:

- Connecting the extension pole and guide rails, fitted with a sliding surface that meshes into the running surface of the guide rail.
- They are screwed into the left and right of the end of the bottom section.

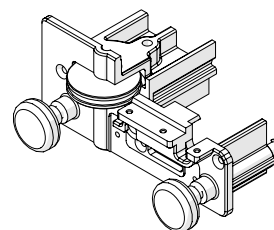

### Guide rail covers

Material: cast aluminium, powder-coated.

Colour: same as the frame colour

Function:

- Covering the guide rails
- Guiding the cord

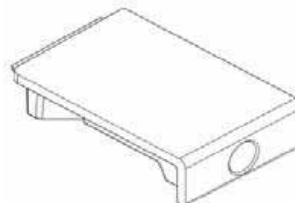
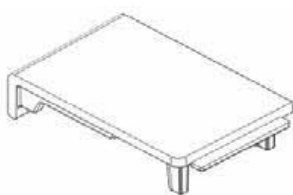
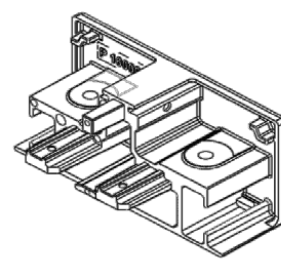
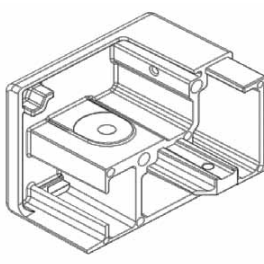
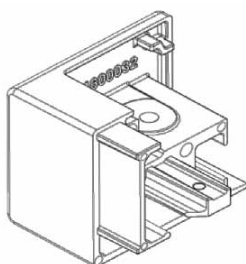

## Tension system

Material: castors, axles, etc. are made of non-corroding materials.

Function: The fabric and bottom section can be kept under constant tension using a spring, castors and Ø 2.7 mm cord.

This keeps the fabric at a certain distance from the glass roof when unwound, so that there is a ventilation space between the fabric and the roof (to eliminate accumulated heat).

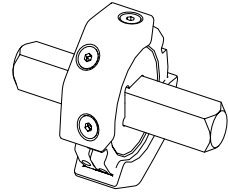

## Connecting parts

Material: Corrosion-resistant material

Function: Pairing two parts of fabric

Adjustable in 8 steps

Note: It is possible that the bottom sections will not simultaneously extend and retract to the fullest, as there may be some slackness in the connection. It is therefore recommended for coupled awnings to place the motor to the widest part.

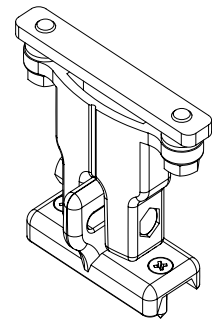

## Guide rail brackets

### S: Standard aluminium bracket

Material: aluminium version, powder-coated in the same colour as the frame.

The attachment system has two parts:

- upper part: attached to the lower part of the lateral and central guides.
- lower part – in two versions:

#### A: Standard SA guide rail bracket

- for veranda roof sections with glass above and wooden pergola and veranda systems
- is attached to wood or into the grooves at the top of the sections

#### B: Standard SB guide rail bracket

- for veranda roof sections with glass below
- is attached to the veranda roof section using two screws (fitting B).
- The upper and lower parts can be laterally adjusted to one another. This allows absorbing positioning deviations between guide section and veranda section.

Standard SA guide rail bracket

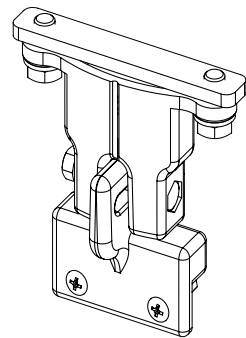

Standard SB guide rail bracket

## Raised brackets

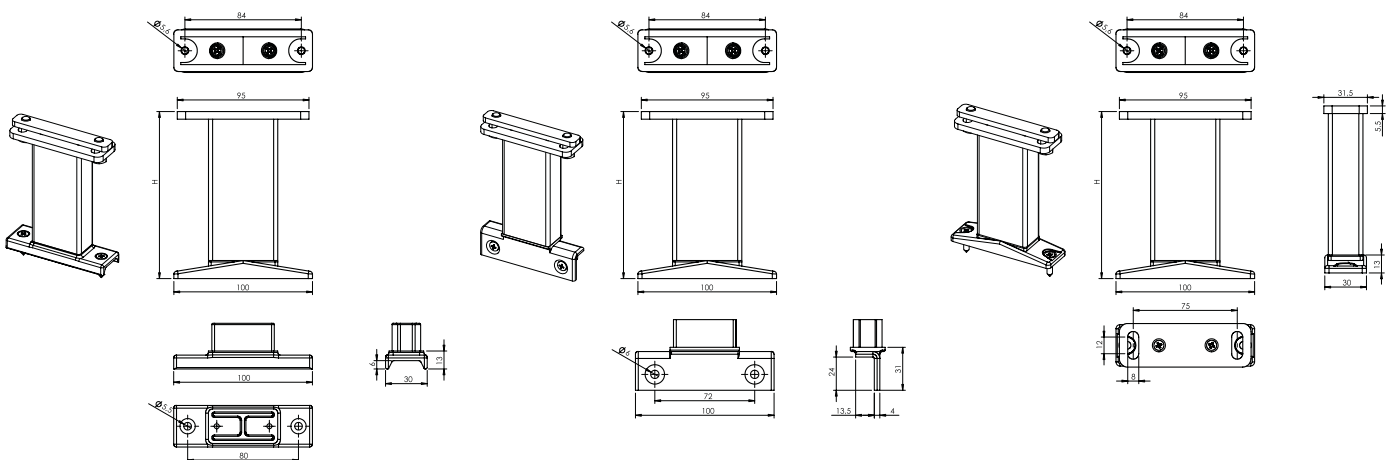

Bracket VL Av (2-01410-PU11X)

Bracket VL Bv (2-01411-PU11X)

Bracket VL Cv (2-01412-PU11X)

The clearance between the guide rail and the glass can be increased by elevated supports. When doing this, take into account that the veranda sections will be subjected to heavier loads when using elevated supports. For this reason, they can only be used when there is no danger of them twisting. If required, each guide rail must be supported. The raised brackets are available in the lengths of 120 mm, 200 mm, 300 mm or 400 mm. The maximum permitted distance between two guide rail attachment points is 1600 mm.

## Wall attachment

Other installation options:

If it is impossible to use attachment methods A or B, you can use a wall attachment option. There are 3 standardised L-sections available that can be provided in any desired length (while Cv flat supports must always be used).

The following sizes are available:

- Type L1 = 50 × 30 × 3 mm
- Type L2 = 100 × 50 × 3 mm
- Type L3 = 130 × 50 × 5 mm

For extension length up to 3 m, only 1 profile is used. For extension length over 3 m, 2 profile pieces are used.

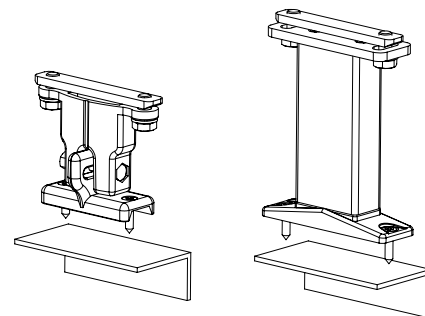

**Wall attachment**

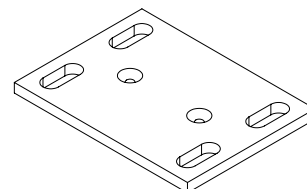

**Coupling plate**

## Coupling two lateral guides

Two veranda sun blinds can be coupled using necessary coupling components.

There are two aluminium coupling components:

### Coupling plate:

- The plate is placed underneath the 2 lateral guides. The plate includes 4 holes for the screws to be driven into the grooves of the guide rails (2 per guide rail) to secure the plate.
- There are 3 holes for attaching the raised brackets in the middle of the plate.

### Coupling angle:

- The angle is placed underneath the 2 lateral guides. The horizontal surface placed underneath the guides contains 2 holes for the screws to be driven into the grooves of the guide rails (1 per guide) to secure the angle.
- The vertical part has 1 hole for attaching the A or B brackets.

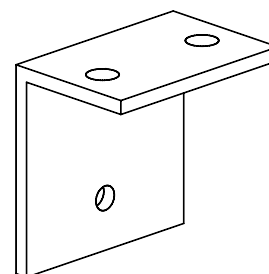

**Coupling angle**

### Coupling set:

The set consists of the coupling plate and the coupling angle with corresponding fasteners.

Function:

- When using a raised bracket in the middle, the section of the raised bracket is directly attached to the coupling plate. In that case, the upper part of the raised bracket will not be used.
- If the standard bracket is placed in the middle, the upper part of the bracket must be replaced by the coupling angle.
- If the bracket is placed on the left or right side of the guide rail, the coupling is to be independent of the bracket by mounting the coupling plate behind the bracket.

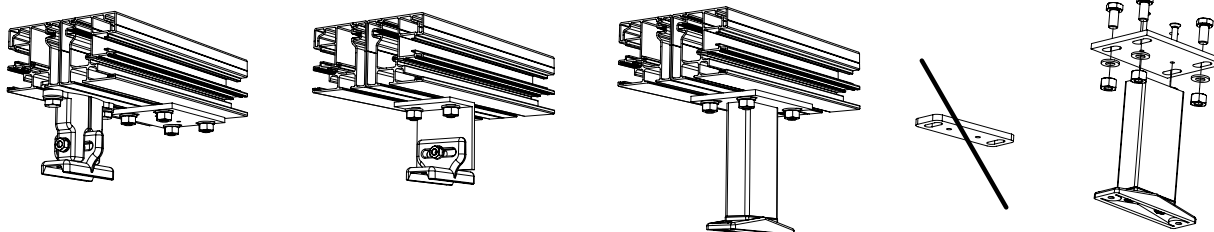

**Bracket placed under the left or right guide rail**

**Standard bracket placed in the middle**

**Raised bracket placed in the middle**

Height	Number of brackets per guide rail
1600	2
3200	3
3500	4
6000	5

Note: Cannot be used without the brackets. The guide rail sections are not self-supporting.

### Technical options

Minimum width per 1 part:	1.5 m
Maximum width per 1 part:	6 m
Maximum drop:	6 m
Maximum fabric area:	25 m <sup>2</sup>

### Technical options – verandas coupling

Typ	Maximum width (m)								Max. area	Number of verandas	Number of motors
	1,5	3	4,5	6	8	12	14	16			
Type 1		1 veranda							25 m <sup>2</sup>	1	1
Type 2		2 verandas							48 m <sup>2</sup>	2	1*
Type 2		2 verandas							50 m <sup>2</sup>	2	2
Type 3		3 verandas							73 m <sup>2</sup>	3	2
Type 4		4 verandas							96 m <sup>2</sup>	4	2

\* From a width of 4001 mm for one part of fabric: only Soltis 86 and Soltis 92 fabrics can be used

Note: Due to weight, the bottom profile for larger widths may sag.

## Controls

The installation is driven by a tubular motor 230 V (50 Hz) located on the far left or far right, as necessary. Control location when viewed from the outside. The standard supply includes the Sunea IO motor type without push buttons, being controlled by an IO transmitter, a 3-metre supply cable, and a wall-mounted, single-pole switch.

Optional:

- 5- or 10-metre supply cable
- The distance can be increased by using a connecting box.
- No switch.
- **Motor with automatic pre-setting; the shade will always fully retract (Orea WT):**
  - no control push-buttons; the end positions will be set by a cable and regulating set,
  - parallel connection (number acc. to the switch type),
  - 3-metre supply cable,
  - wall-mounted, single-pole switch.
- **Motor with a built-in RTS receiver (Orea RTS):**
  - 3-metre supply cable – a 5, 10-metre cable can also be used,
  - wall-mounted RTS transmitter – optionally without the wall-mounted RTS transmitter.
- **Motor with a built-in IO receiver (Sunea IO):**
  - 3-metre supply cable – a 5, 10-metre cable can also be used,
  - wall-mounted IO transmitter – optionally without the wall-mounted IO transmitter.

The RTS and IO motors are supplied with activated options for “back shutdown” and “reduced closing force”.

Outlets (cables)

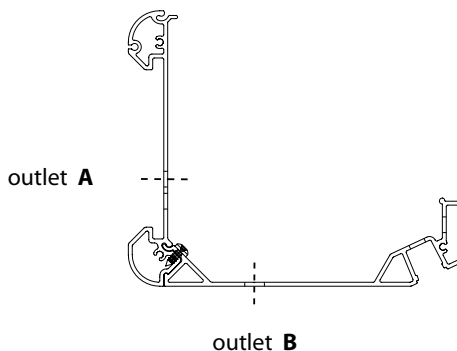
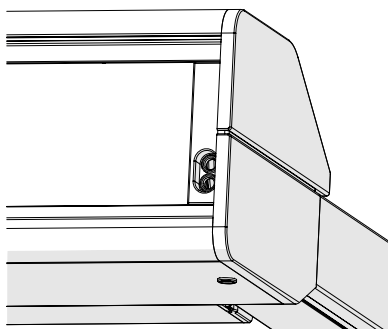

## Accessories:

- Relay boxes,
- Controls using the wind/sun sensor,
- Time switches,
- Remote control,
- and others.

## Motor control

Types of motors

### VERANDA HRV80-ZIP

item name	trade name - abbreviation 2	order number - abbreviation 1
Motor OREA 50 WT 40/17	MR 096/40	6-001550-0040
Motor OREA 60 WT 55/17	MR 096/55	6-001550-0055
Motor OREA 60 WT 70/17	MR 096/70	6-001550-0070
Motor OREA 60 WT 85/17	MR 096/85	6-001550-0085
Motor OREA 50 RTS 40/17	MR 092/40	6-011171-0040
Motor OREA 60 RTS 55/17	MR 092/55	6-011171-0055
Motor OREA 60 RTS 70/17	MR 092/70	6-011171-0070
Motor OREA 60 RTS 85/17	MR 092/85	6-011171-0085
Motor Sunea 50 io 40/17	MR 134/40	6-012559-4017
Motor Sunea 60 io 55/17	MR 134/55	6-012559-5517
Motor Sunea 60 io 70/17	MR 134/70	6-012559-7017
Motor Sunea 60 io 85/17	MR 134/85	6-012559-8517

### Types of motors (BECKER) for Veranda HRV80-ZIP

item name	trade name - abbreviation 2	order number - abbreviation 1
Motor BECKER 50 E 40/17	17BE	6-017852-0040
Motor BECKER 60 E 60/17	17BE	6-017852-0060
Motor BECKER 50 E 40/17	BC40	6-017852-0040
Motor BECKER 60 E 60/17	BE60	6-017852-0060
Motor BECKER 60 E 70/17	BE70	6-017852-0070
Motor BECKER 60 E 120/11	BE120	6-017852-0120
Motor BECKER 50 C 40/17	16BC	6-017853-0040
Motor BECKER 60 C 60/17	16BC	6-017853-0060
Motor BECKER 50 C 40/17	BC40	6-017853-0040
Motor BECKER 60 C 60/17	BC60	6-017853-0060
Motor BECKER 60 C 70/17	BC70	6-017853-0070
Motor BECKER 60 C 120/11 PLUS	BC120	6-018886-0120

Note: E=electronic motor, C=radio motor

## VERANDA HRV80-ZIP

### Measurement and assembly instructions

#### 1. General information

To a great extent, the HRV80-ZIP veranda screen allows regulating the sunlight penetration into a room and thus avoids unpleasant high amount of light and heat. The fabric is protected when rolled in the box which is closed by bottom section in the fully retracted position. The box is attached to guide rails.

Safe distance between the fabric and the veranda roof is ensured by the guide rails and the spring system that keeps the fabric taut continuously. This system is designed to easily overcome any small tolerances of roof construction. The whole system is made from corrosion-resistant materials.

There are several installation options available. The standard option is having the HRV80-ZIP blind installed above the veranda, as the most efficient sun protection is above the glazing. Then it can be installed to the veranda sections using the various types of brackets available. The HRV80-ZIP screen is equipped with a zipper system that ensures the fabric stays properly taut in every position of the bottom section and avoids fabric slipping out from the guide rails. The individual parts of the fabric are always fitted with a zipper on both the left and right side, while the thicker part locks with the plastic zipper section inserted in an aluminium guide rail.

The HRV80-ZIP veranda screen consists of the following parts:

- Box with an easily removable, motor-driven winding cylinder,
- Fabric with a zipper, wound in the box,
- Guide rails for easy connection of the zipper section,
- Bottom section with a spring that keeps the fabric taut.

#### 2. Installation options

The HRV80-ZIP screen can be installed in one way only – to the supporting structure top down.

- Exterior installation.
- The fabric is placed on the outside.
- The sun screen is visible from the outside.
- The zipper is on the window side.
- In Soltis 86 and 92 fabric, the aluminium side faces the sun.
- In blackout fabrics, the grey film is on the window side.

Note: It is necessary to observe the minimum slope requirements for the fabrics, otherwise water will accumulate on the fabric, which will bend and possibly deform permanently. This would void the guarantee. If the screen remains open during the rain, water will uncontrollably flow to the sliding blocks of the bottom section. There is no water collecting mechanism (eaves) under the guide rails.

The minimum gradient of slope for Soltis 86 and 92 fabrics is 14°.

With integrated LED illumination, the minimum slope is 14°!

The minimum gradient of slope for blackout fabrics is 14°!

The maximum gradient of slope for all variants is 30°!

If the minimum inclination angle of the fabric is not observed, a support profile must be ordered. Order only on consent statement.

Fabric Infinity:

The minimum gradient of slope for Infinity fabric is 14°

The veranda with extension  $\geq 3200$  mm is covered with horizontal stitching.

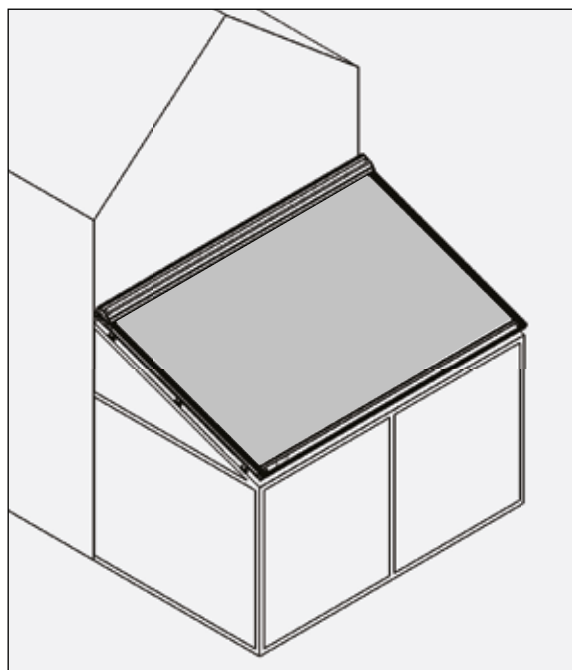

#### 3. Installation

Note: Ensure perpendicularity of installation at all times, otherwise fabric wrinkling will occur.

See the overview of installation brackets.

Attention: The maximum distance between two guide rail brackets is 1600 mm.

The maximum overhang is 500 mm.

Make sure the box and the bottom profile can always be opened and that the mechanical parts inside are accessible at all times. Should you fail to follow this rule, ISOTRA cannot be held responsible for the cost of demolition work!

#### 4. Measuring

Overall width = from the centre of the guide rail to the centre of the guide rail. The outer part of the box is always 40 mm (2× 20 mm) wider than the centre of the guide rails or the centre of the attachment brackets.

Drop: measured from the rear part of the box on the upper side touching the wall to the front side of the guide rail including the cover.

The final position of the bottom section can be set flush with the end of the guide rail cover.

Note: The box width is always 40 mm greater than the ordered width.

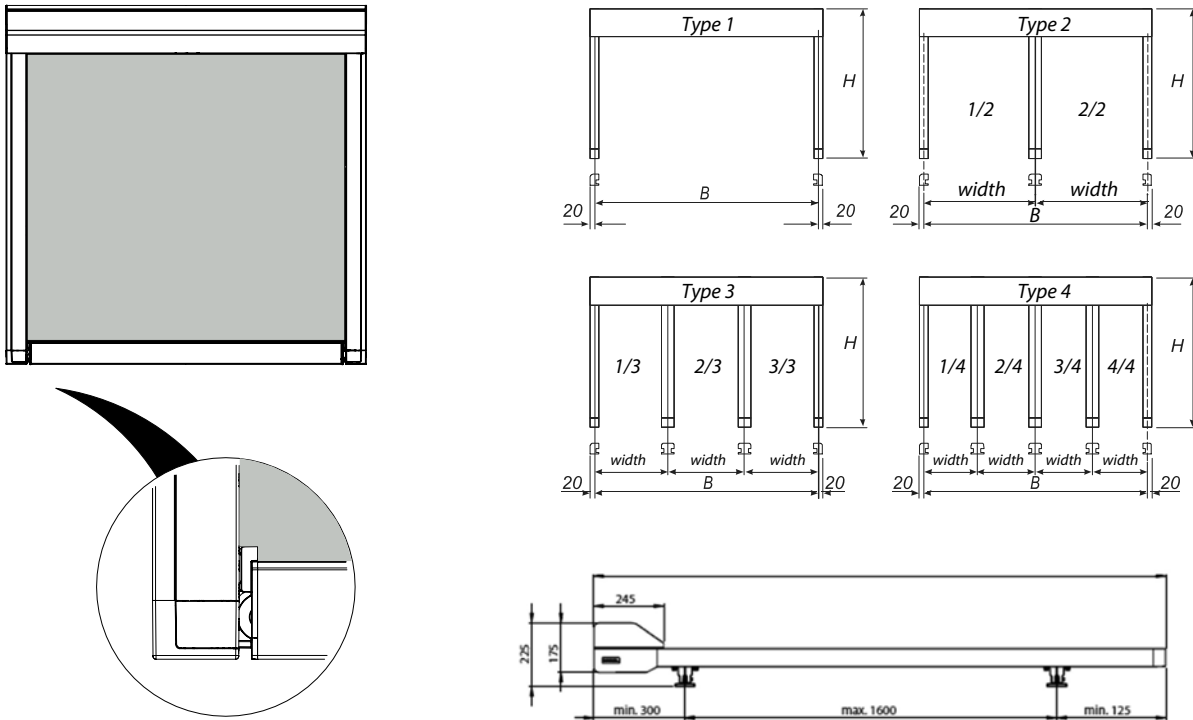

#### 5. Design

The fabric has zippers on the sides, and if the guide rails are properly installed, these zippers ensure the fabric remains taut in any position of the bottom section thanks to the strain between the zipper and the guide rails.

Cracking may be heard when retracting the screen, which is caused by the fabric tension and by pushing the air from under the fabric when winding up. Creases may also form on the zipper side, caused by different material thicknesses and expansion factors.

In blackout blinds, the zippers are placed on the Soltis side of the fabric, not on the side with the blackout film, in order to attain better adhesion and reduced fabric movement. It is therefore possible that due to wind or if seen at an angle, a small part of the zipper can be seen, but this is insignificant when compared with the overall view or the fabric tension (reduced creasing).

When the 86/92 fabric is used, the zippers are always on the rear side of the fabric – i.e. on the window side. In addition to placing an inscription or a logo to the fabric, it is also possible to inverse the fabric colour or the fabric side on the sun screen.

#### 6. Blackout

The Veranda can also be used to blacking out the room, i.e. to protect it from light coming from the outside during presentations or projections, but it is not a 100% blackout during which it would be possible to develop photographs.

The following must be taken into account to achieve proper blackout:

- It is only possible by using a blackout fabric.
- The spaces between the guide rails, the box, the wall and the window frame must be carefully sealed (for example, by using silicone, strips, etc.).
- Wind action can cause the bottom lath to waft up, and a gap may occur as a result.
- Account should be taken of a small gap between the extension pole and the guide rail.
- Placing an extra angled profile (30×20×2) for the bottom section against the wall reduces the chance of light penetration even more.

## 7. LED osvětlení boxu Verandy – volitelné příslušenství

- remove the aluminium clip profile from the bottom side of the profile
- LED strip is attached, and the opening is covered with a small diffuser profile
- required power supply 230V AC / 24V DC
- each part of the box is equipped with a LED strip and a diffuser, always with its own external power supply, which is located outside the box. IO or RTS or switch (switch is not included)
- LED strip is always installed along the entire width of the veranda. There may be less intense light at the ends of the strip depending on the length of the LED strip
- LED strip is powered by 24V DC, 9.6 W/m source. The lighting colour is warm white.
- LED unit can only be used as supplementary lighting.

### Control:

#### 1. Dimmable IO control:

LED lighting cannot be controlled by the Smoove IO controller

#### 2. RTS control:

The lighting can be controlled by all RTS controllers

#### 3. With no control:

The included power cable can be connected to a switch (switch is not included)

## 8. Support profile – optional accessory

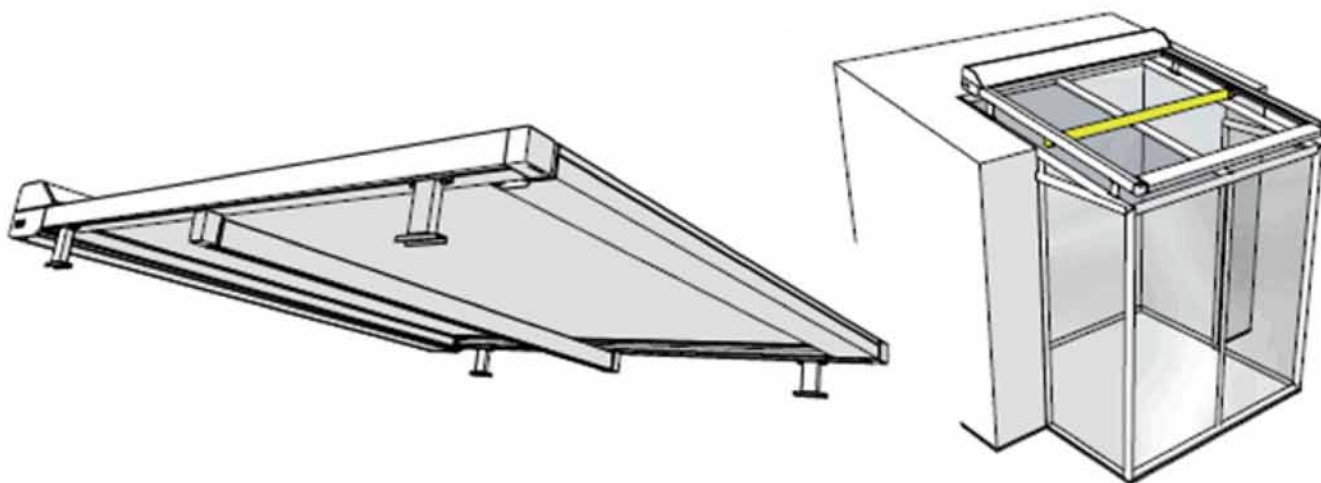

The support profile is always installed in a fixed position, in the center of the guide rails.

### LED lighting can be installed in the support profile

- The profile can be adjusted in the range of 20° in both directions
- One support profile is supplied as standard

### ATTENTION

**VERANDA HRV80-ZIP – the support profile is supplied automatically for extensions over 4 m.**

**VERANDA HRV80-ZIP pp – the support profile is always supplied.**

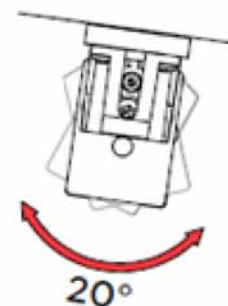

The use of the support profile according to the type of the bracket type used	Support profile
Standard type SA bracket (2-01408-PU11)	cannot be used
Standard type SB bracket (2-01409-PU11)	cannot be used
Raised type AV bracket (2-01410-PU11)	X
Raised type BV bracket (2-01411-PU11)	X
Raised type CV bracket (2-01412-PU11)	X

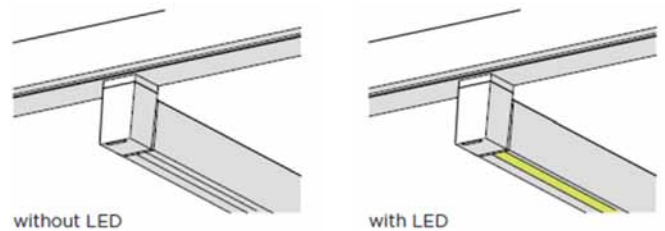

## 9. Fixtures and fittings

All fixtures and fitting are made from stainless steel, and all accessories are always part of the supply.

## 10. Packing

The Veranda HRV80-ZIP is supplied packed in robust cardboard boxes.

## 11. Use and maintenance

Proper use and maintenance greatly increases the lifetime of the sunblind.

- Do not use the screen as protection against rain or wind.
- Regular maintenance prevents excessive wear and operational problems.
- Cleaning the frame: use soft water instead of aggressive substances, that may affect the coating and protective layers.
- Cleaning the fabric: when dry, with a semi-stiff brush.
- Clean stubborn stains using warm water and light detergent solution, rinse with copious amounts of clean water.
- Always let the fabric dry fully before rolling it up (even after an unexpected rain shower).

## 12. Safety

To ensure safety of the end user, the veranda must be installed in strict accordance with the installation instructions.

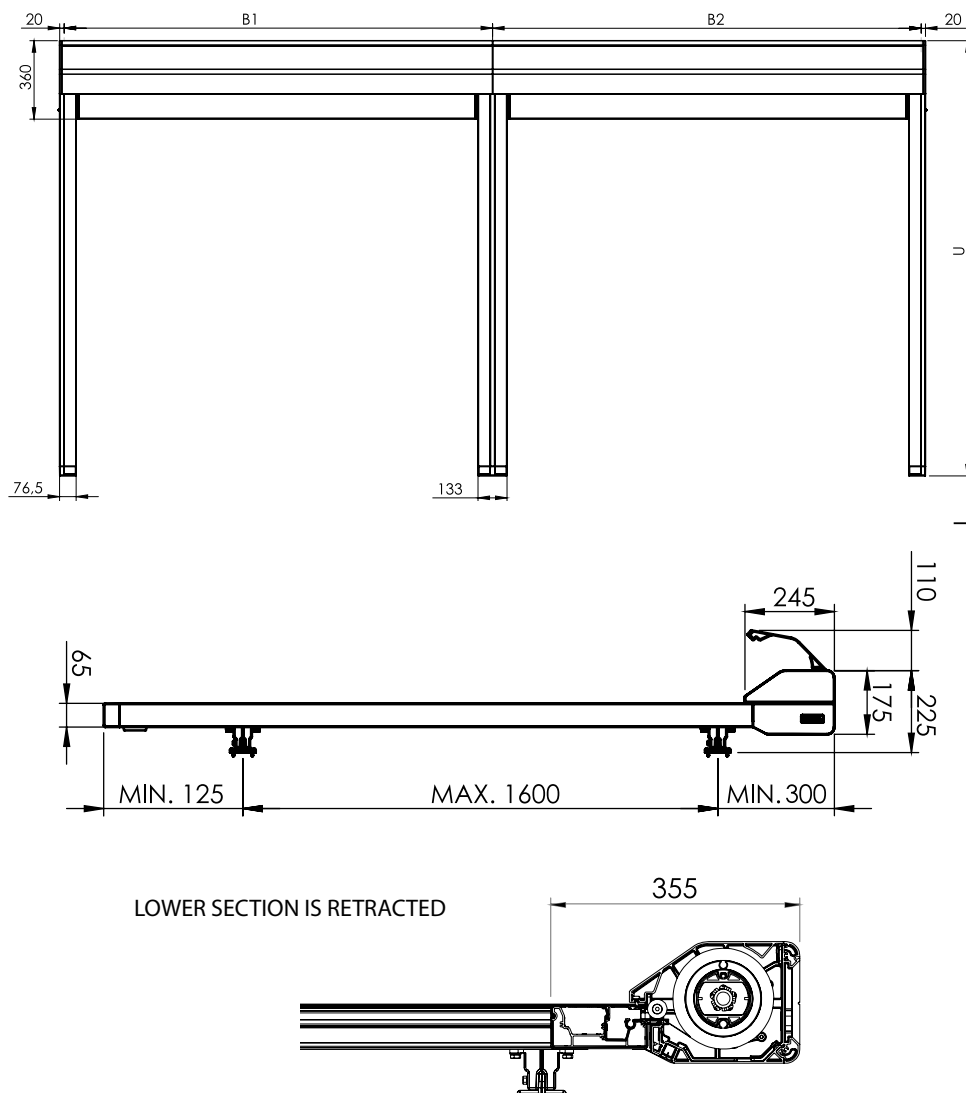

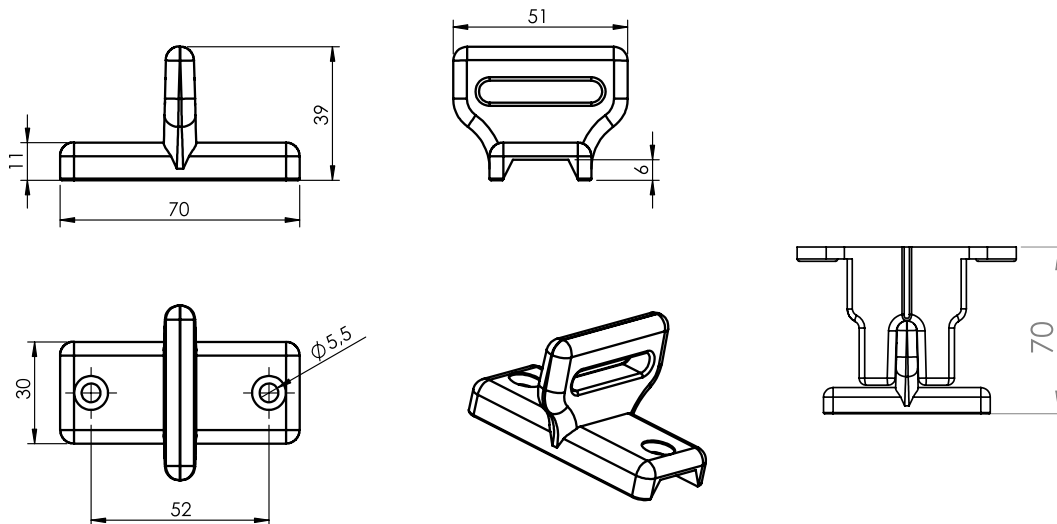

SA bottom bracket – Alu

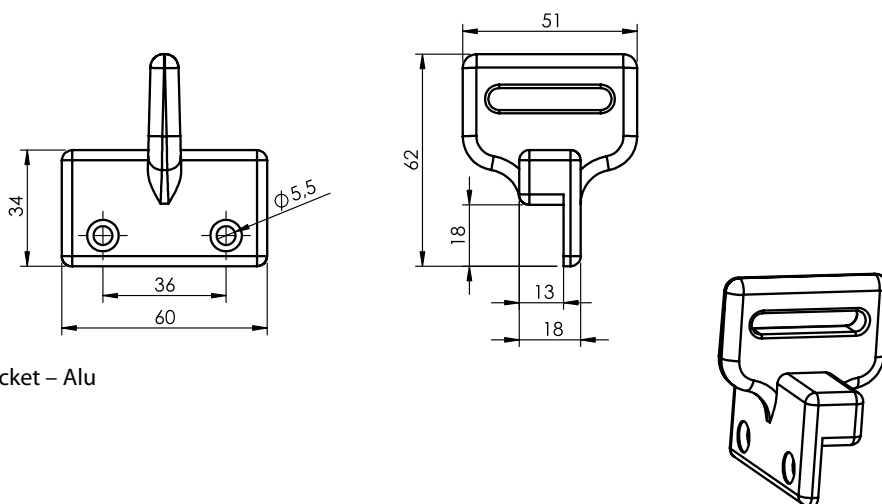

SB upper bracket – Alu

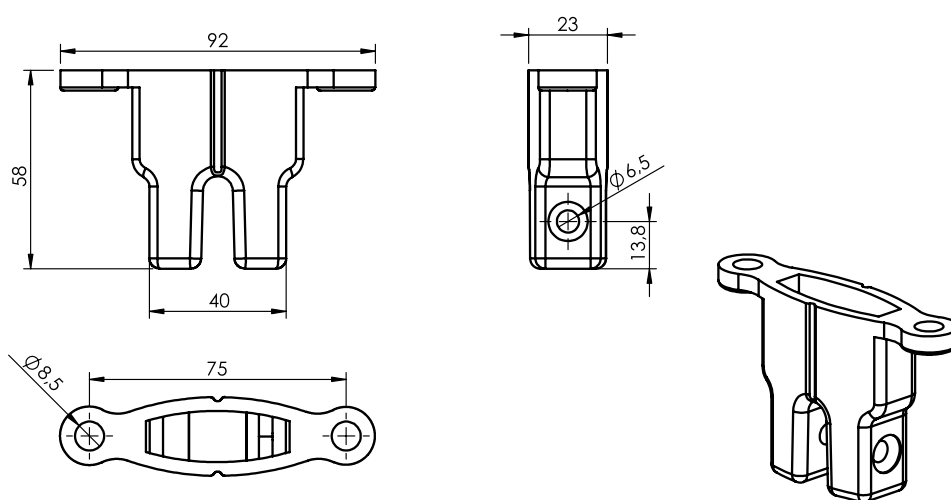

Upper side of the bracket – Alu

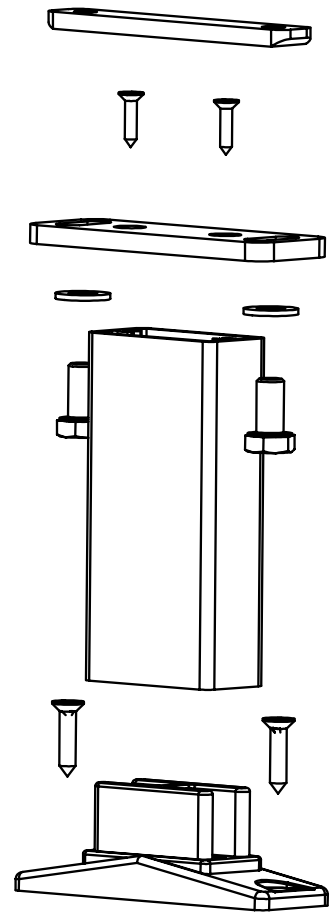
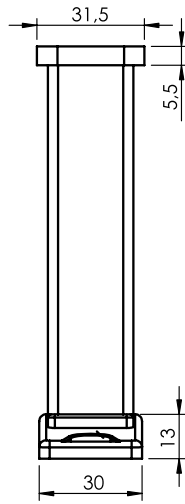
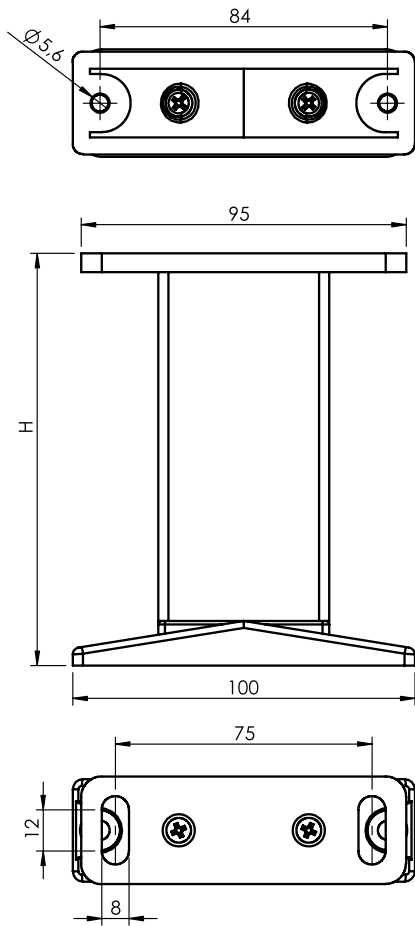

Cv raised bracket – Alu

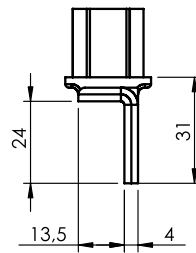
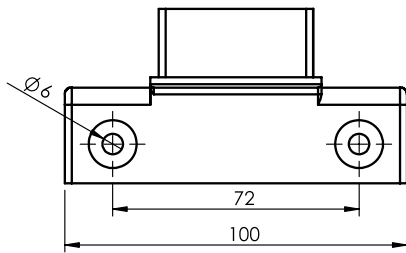

Bv raised bracket foot – Alu

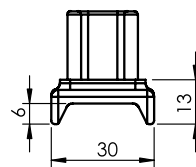
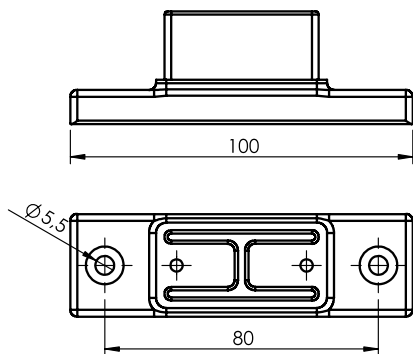

Av raised bracket foot – Alu

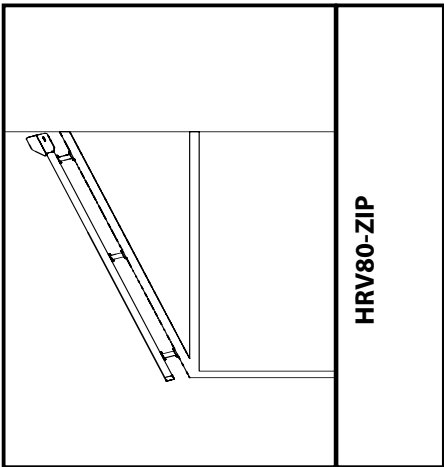

**1**

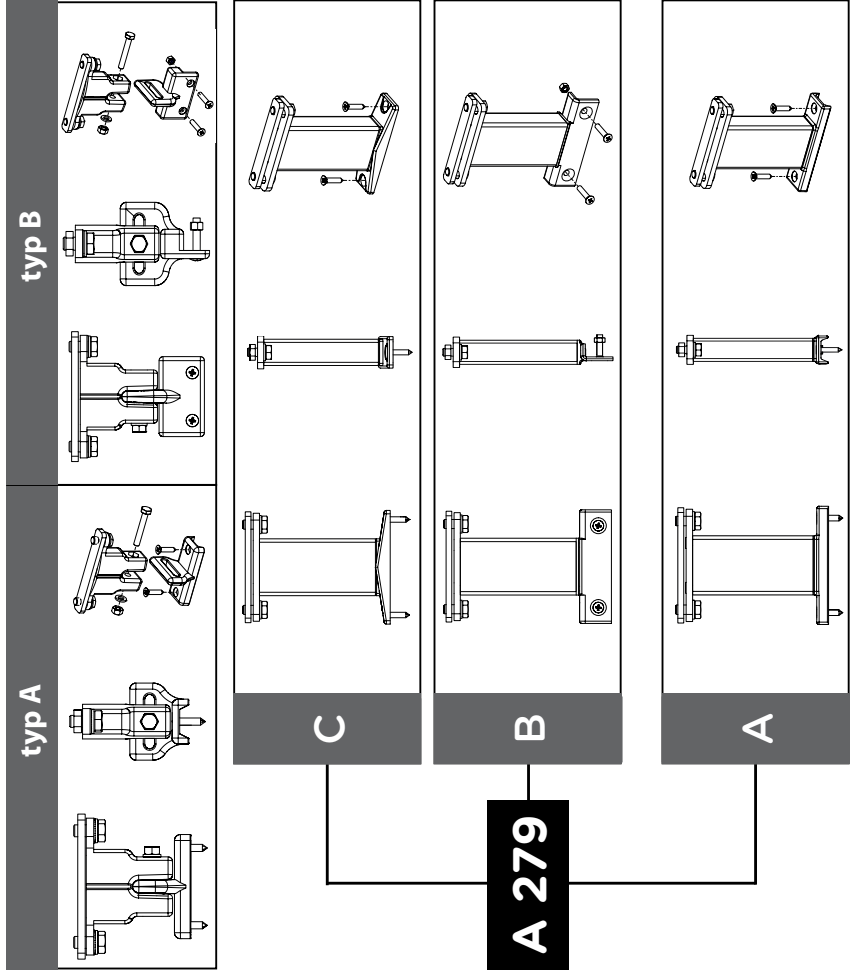
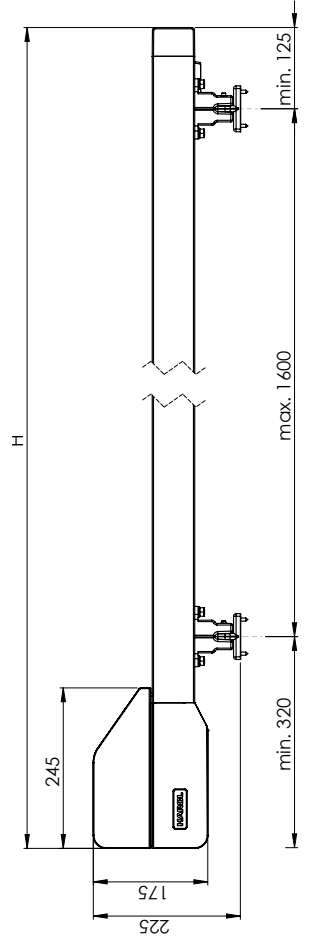
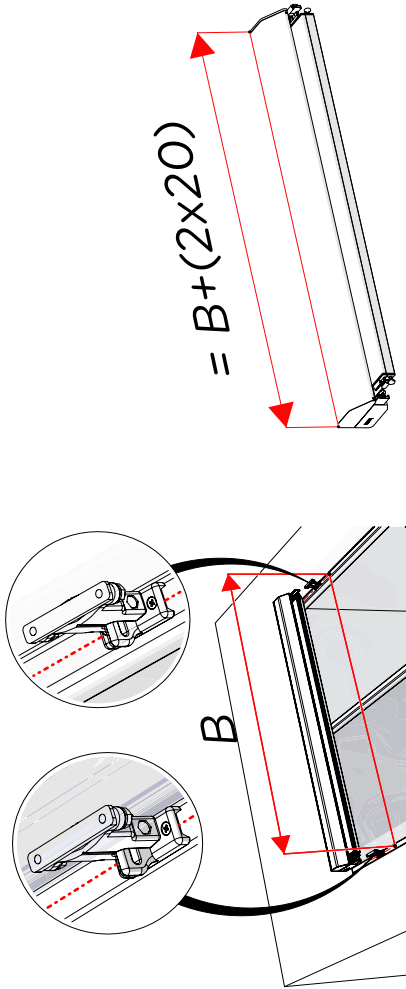
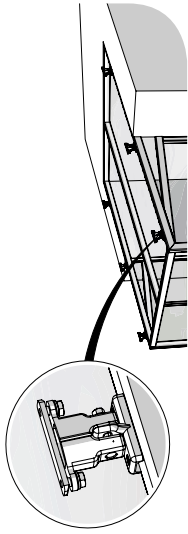
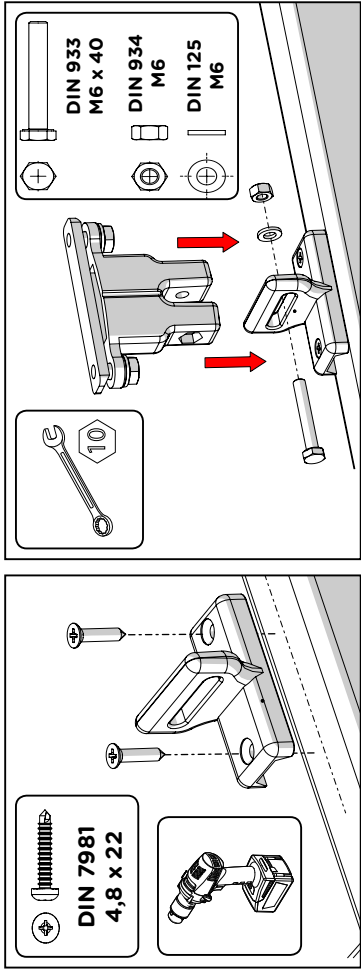
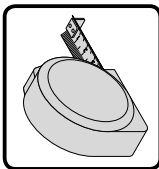

2

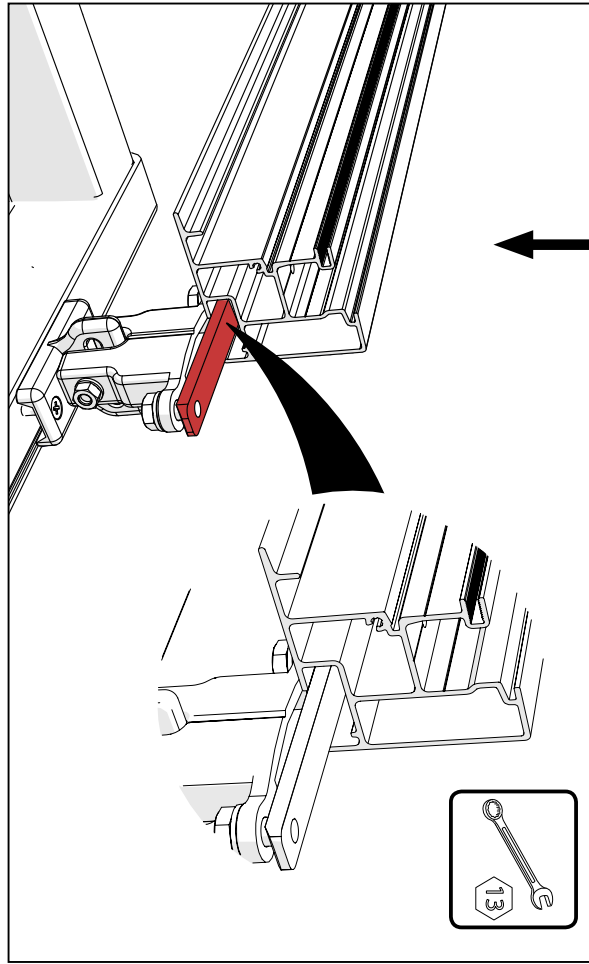
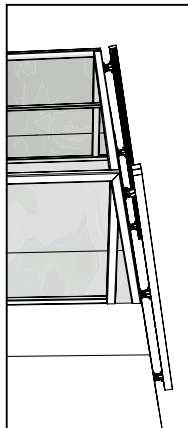
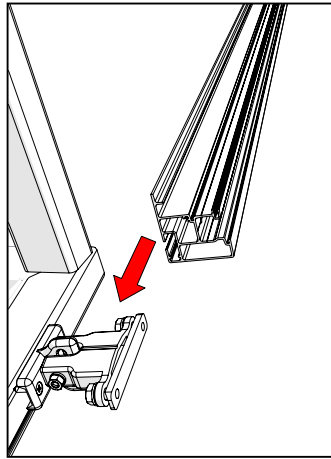
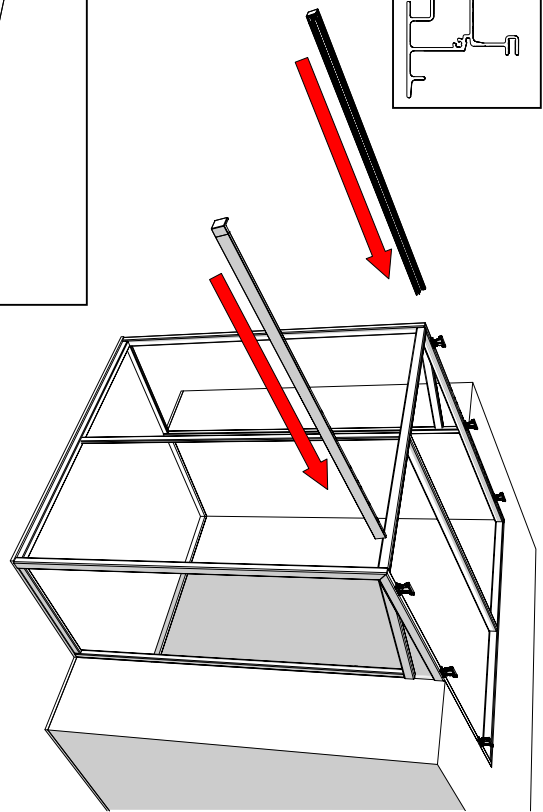
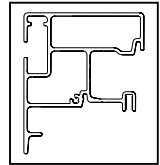

3

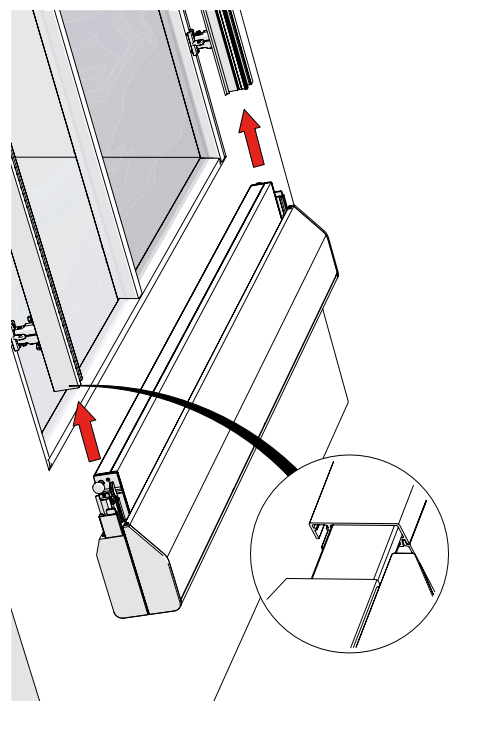

1

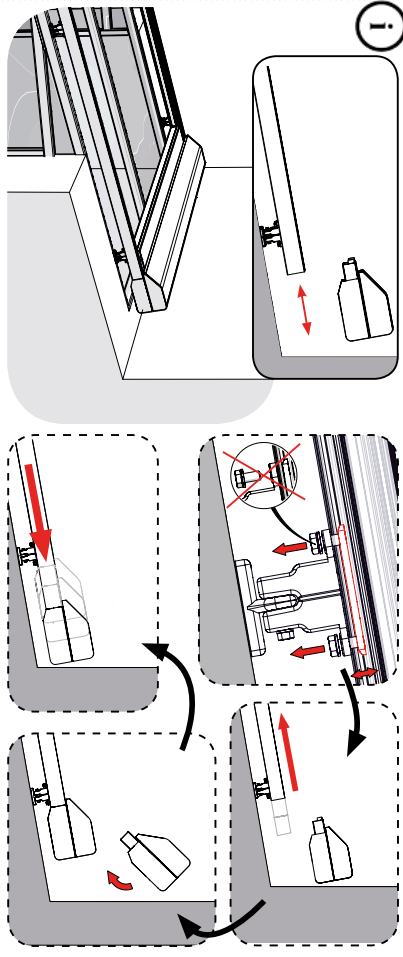

4

DIN 912  
M4 x 25

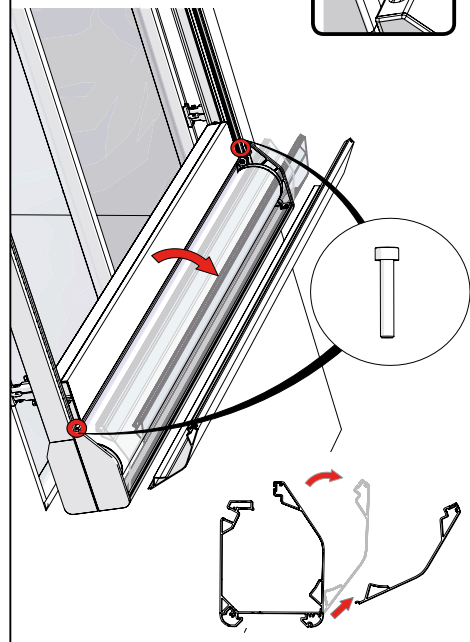
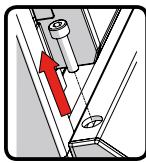
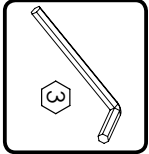

**5** CHECK

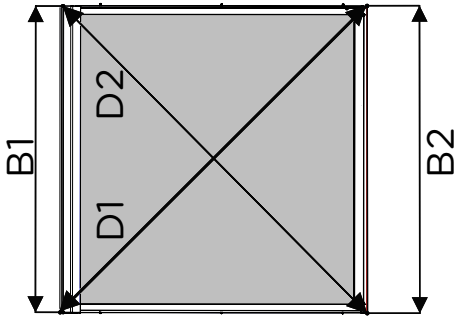
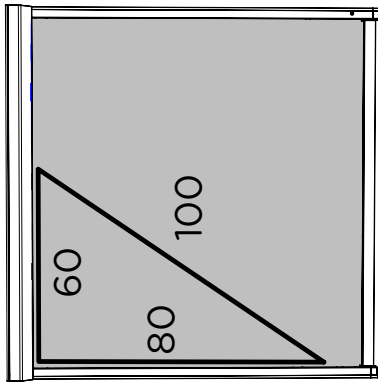

**B1 = B2 & D1 = D2**  
(+/- 2mm)

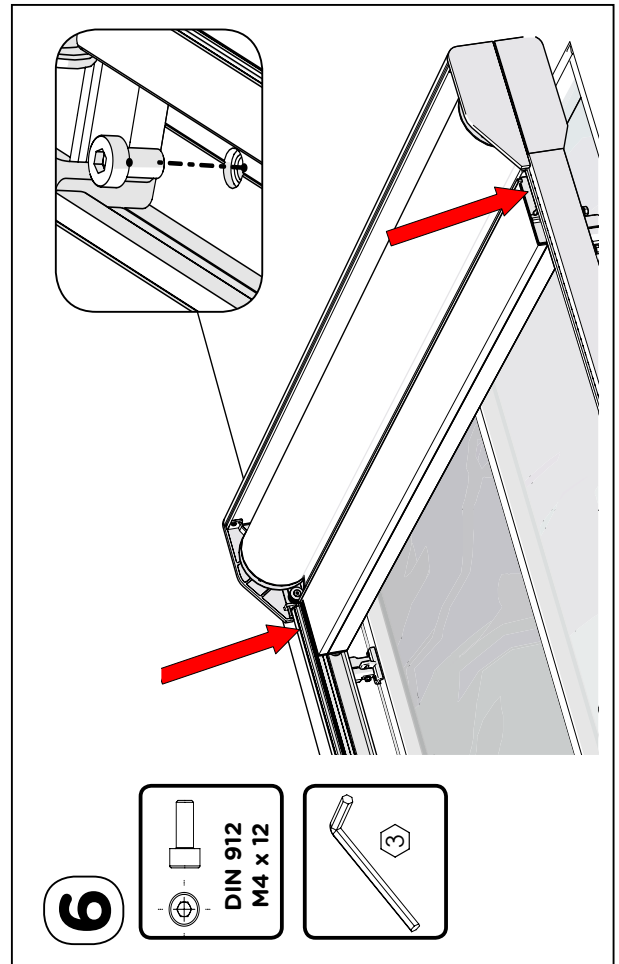

**7**

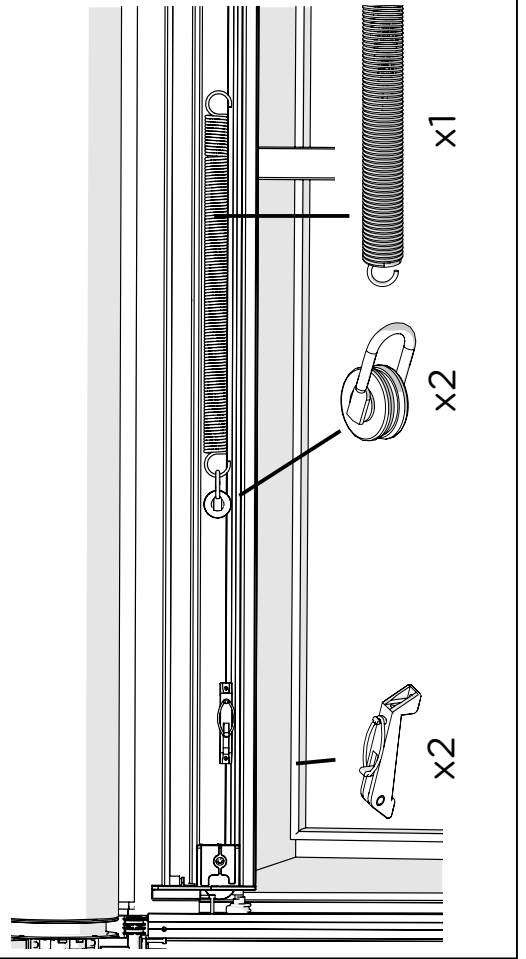
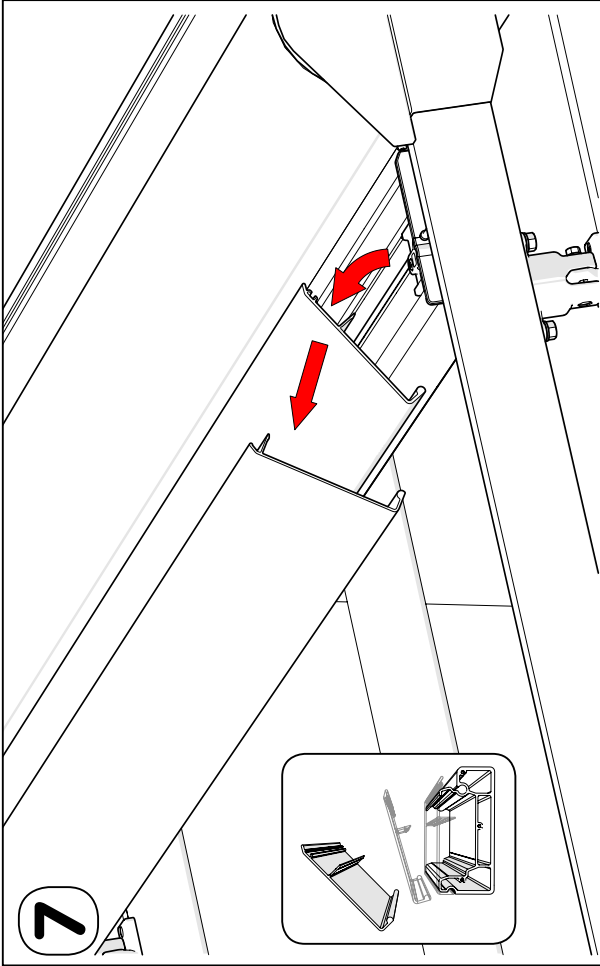

8

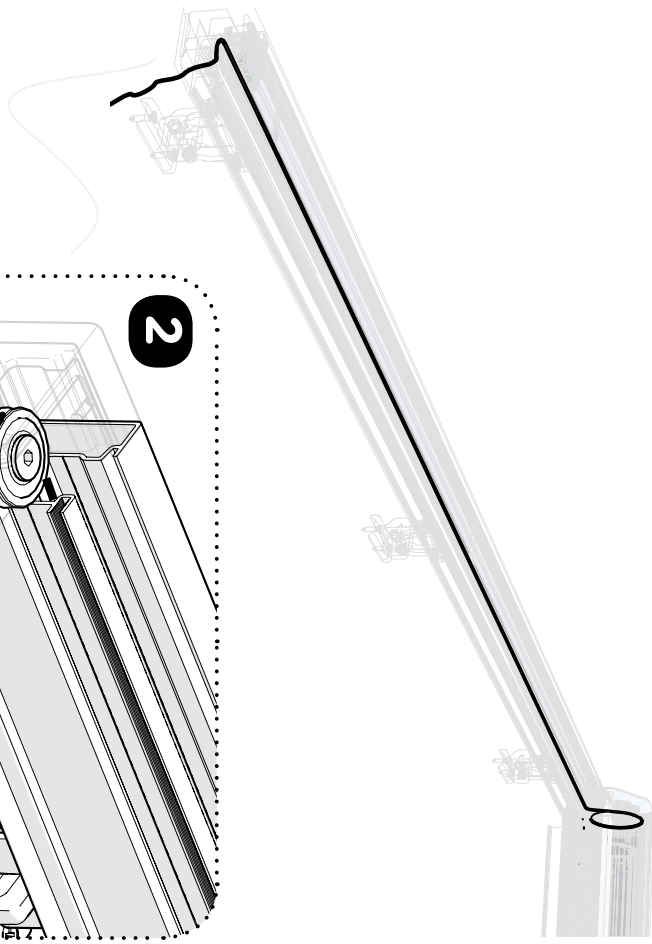
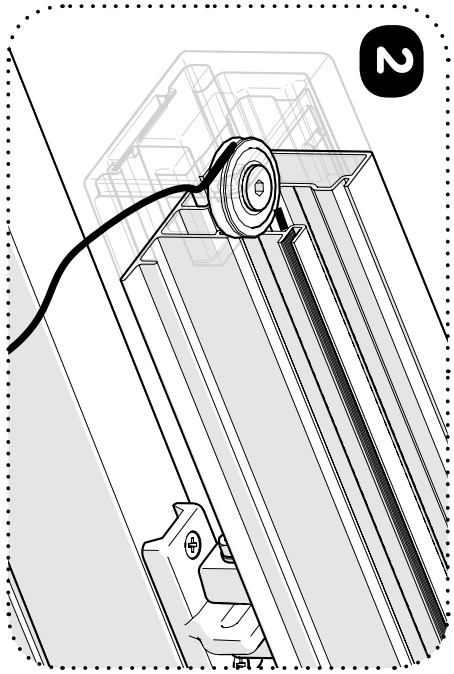
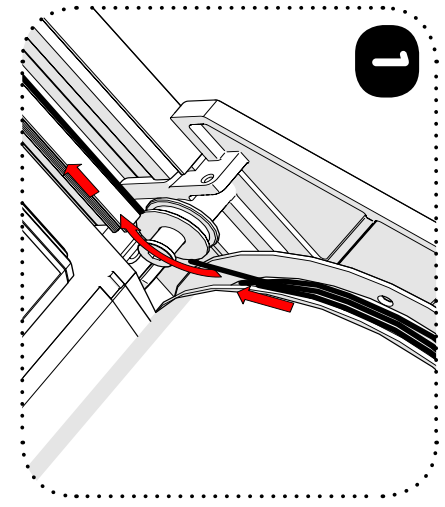
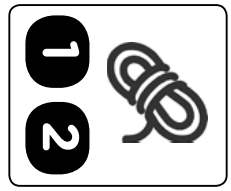

9

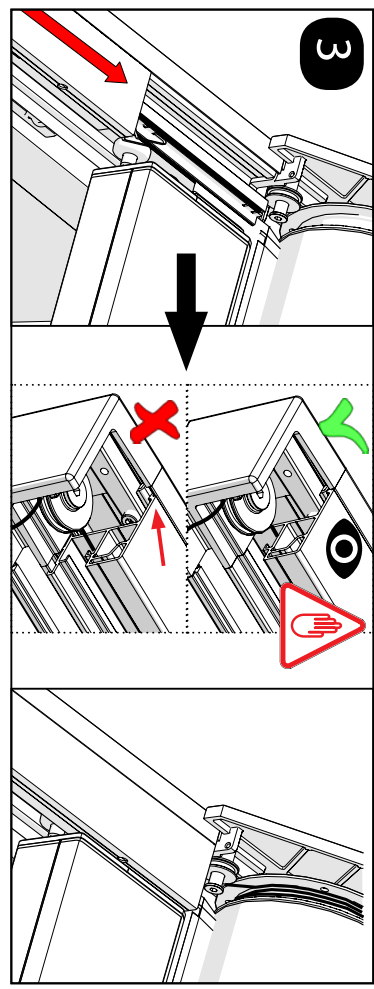
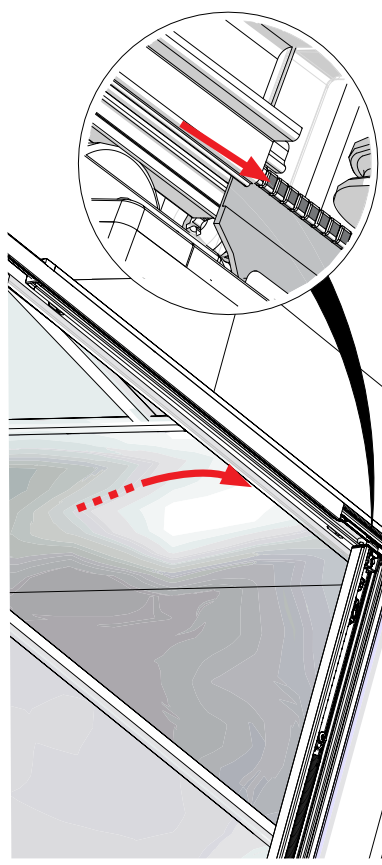
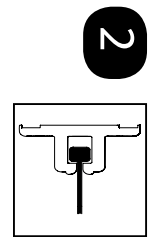
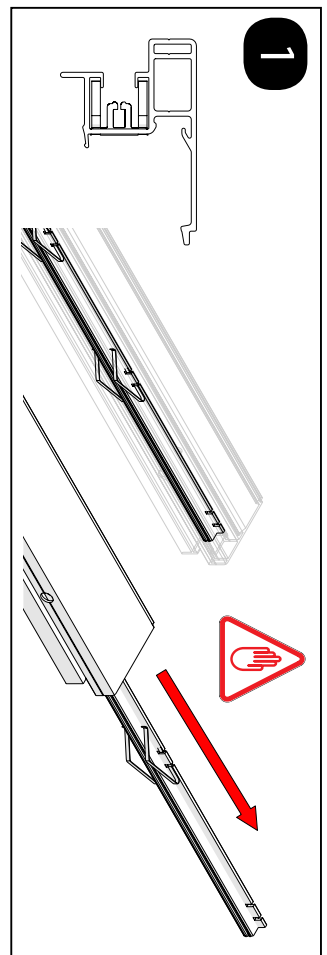

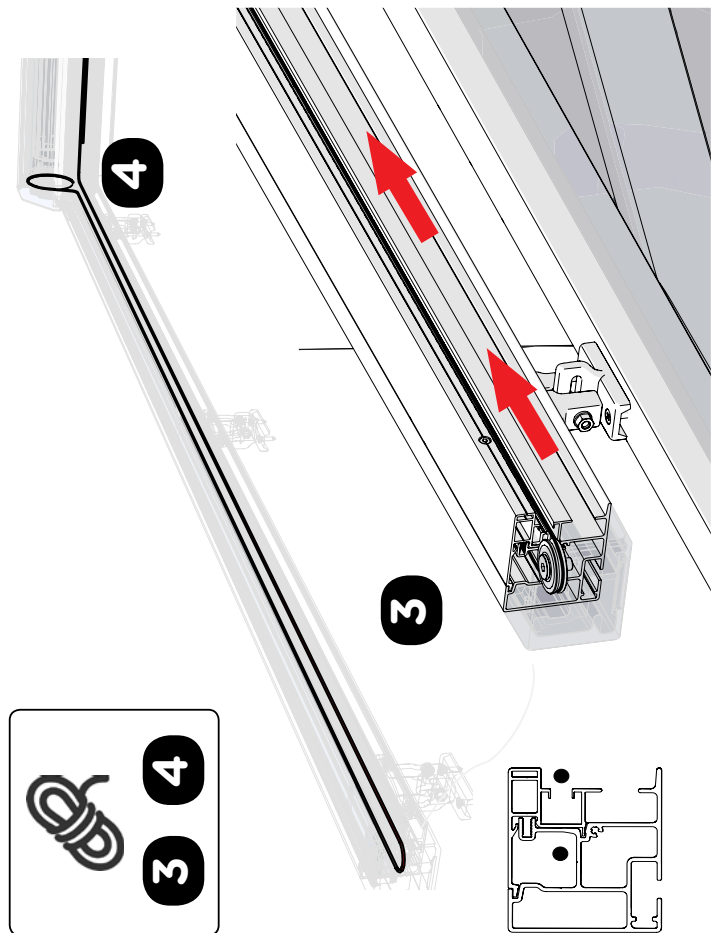
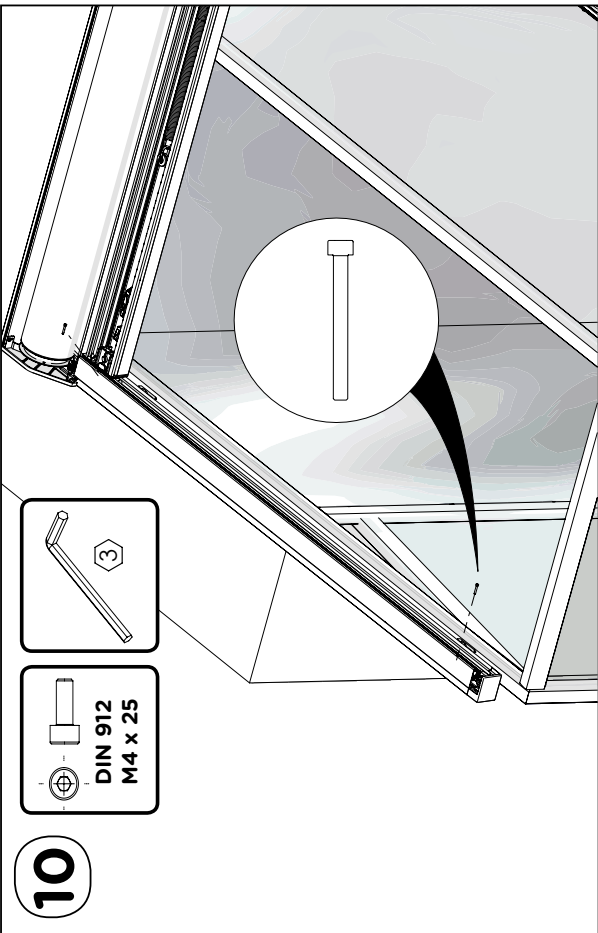
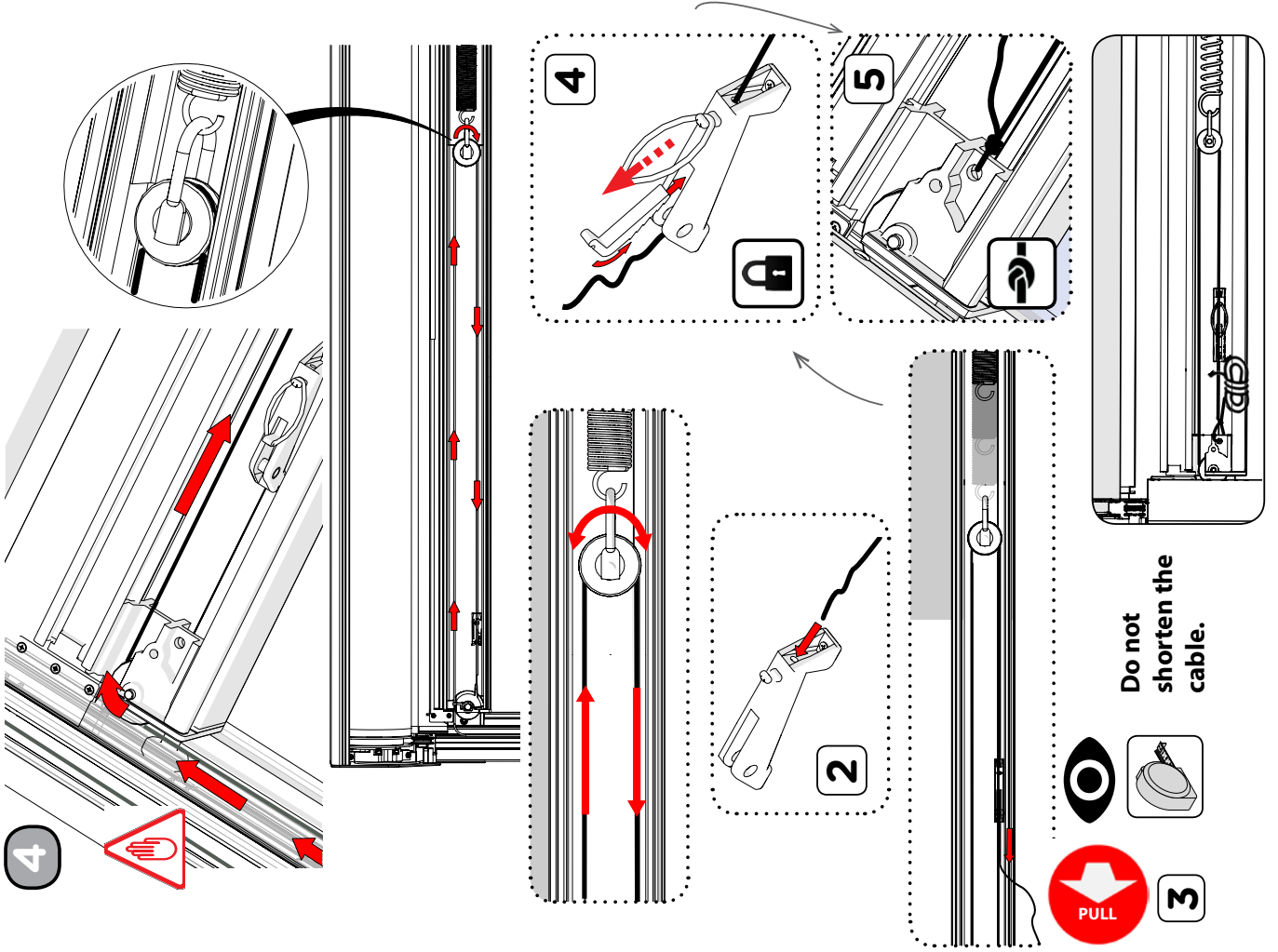

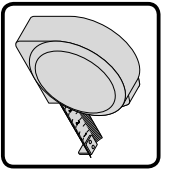
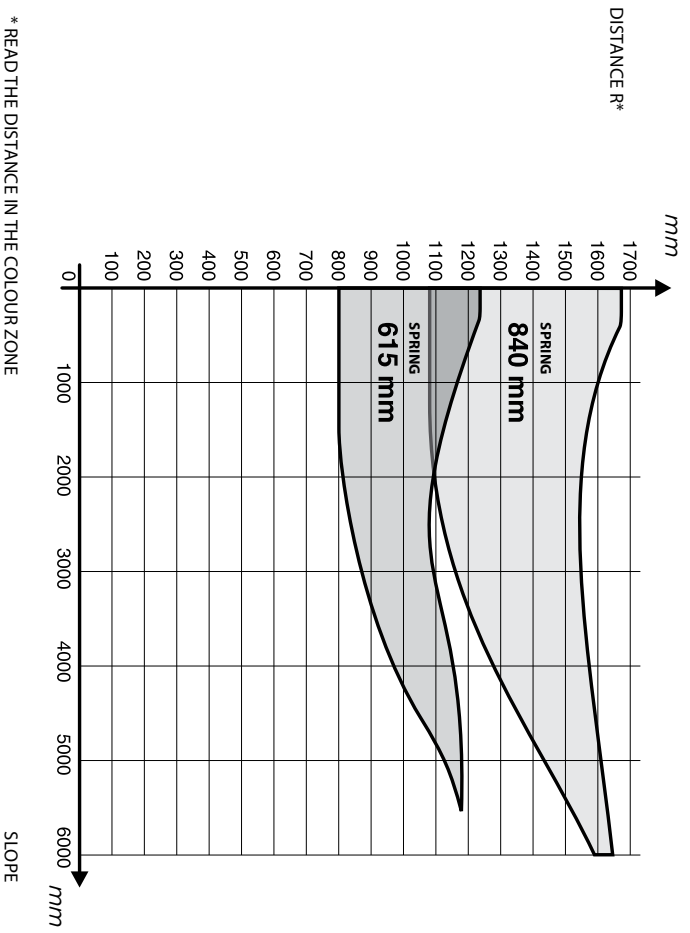
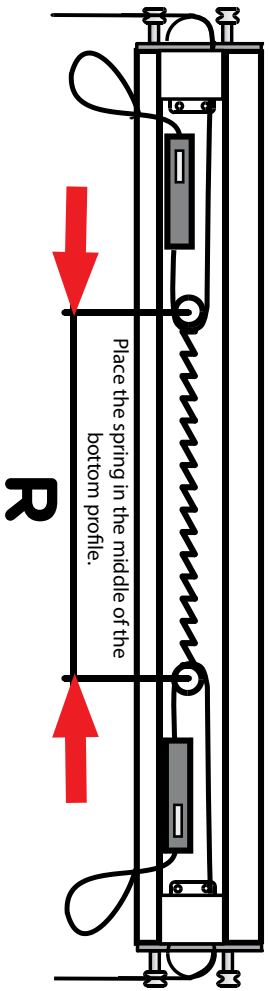
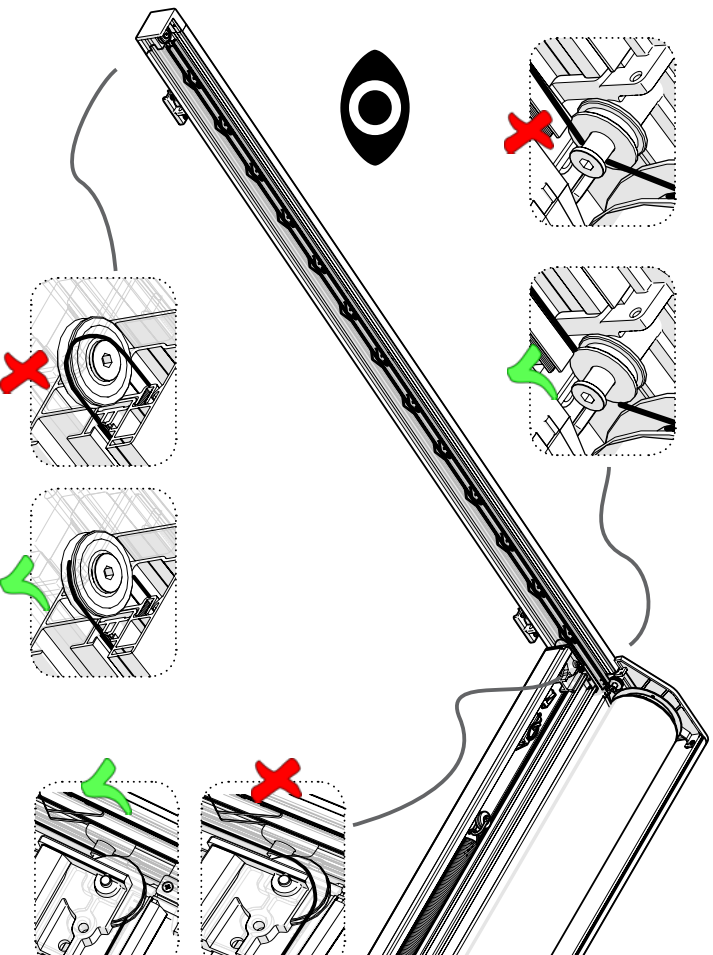
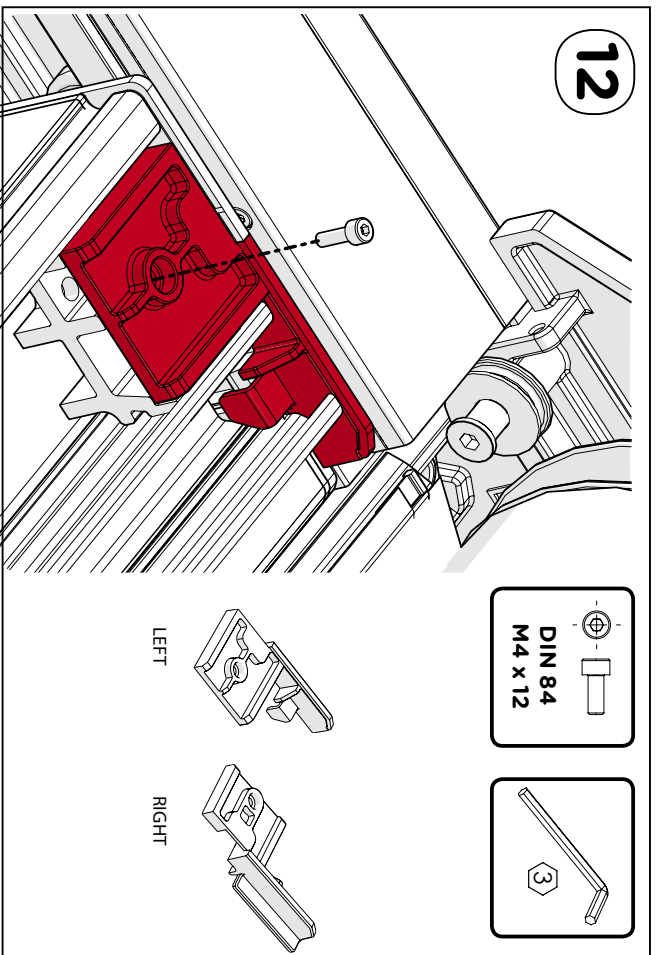

TABLE - SPRING DISTANCE R (IN MM)



\* READ THE DISTANCE IN THE COLOUR ZONE  
DEPENDING ON THE SPRING TYPE (650MM / 850 MM)

Stretch the spring up in the range according to the table (if the spring is overstretched, the fabric may be pulled out of the zipper of the guide rail).





**somfy.**  
www.somfy.com



OREA 50 WT 25/17  
OREA 50 WT 40/17  
Orea 25/17 LT50 RTS  
Orea 40/17 LT50 RTS  
Sunea 50 IO 25/17  
Sunea 50 IO 40/17

SEE SOMFY SERVICE INSTRUCTIONS (PART OF SUPPLY)



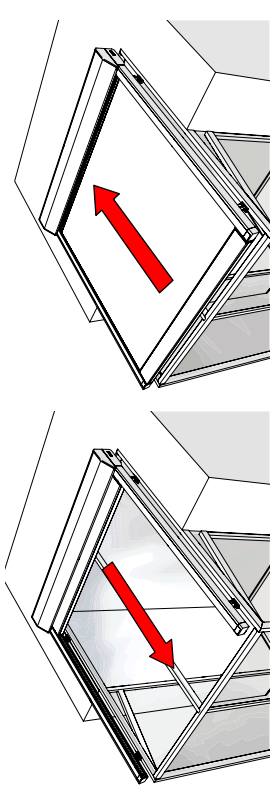

**15**  x1

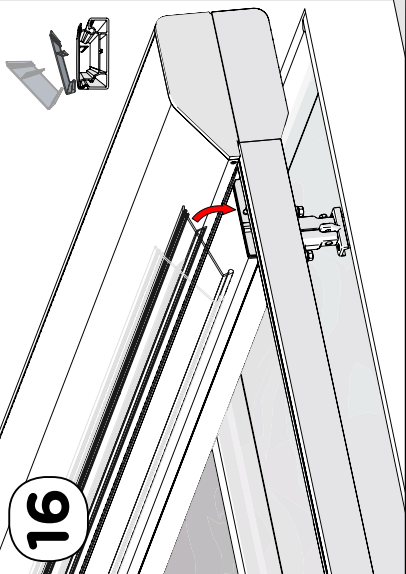

**16**

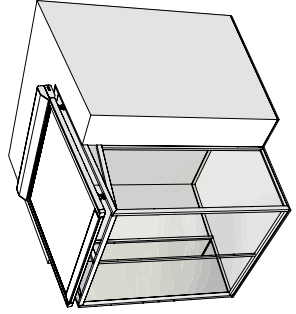
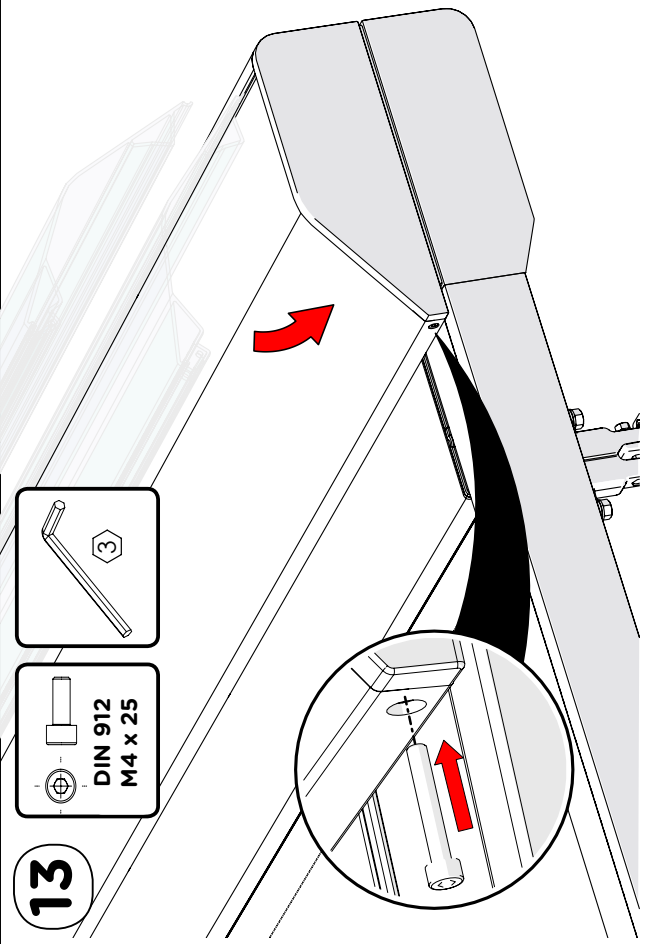
**13**

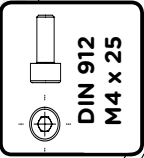

DIN 912  
M4 x 25

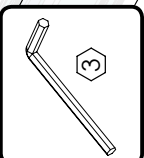

3

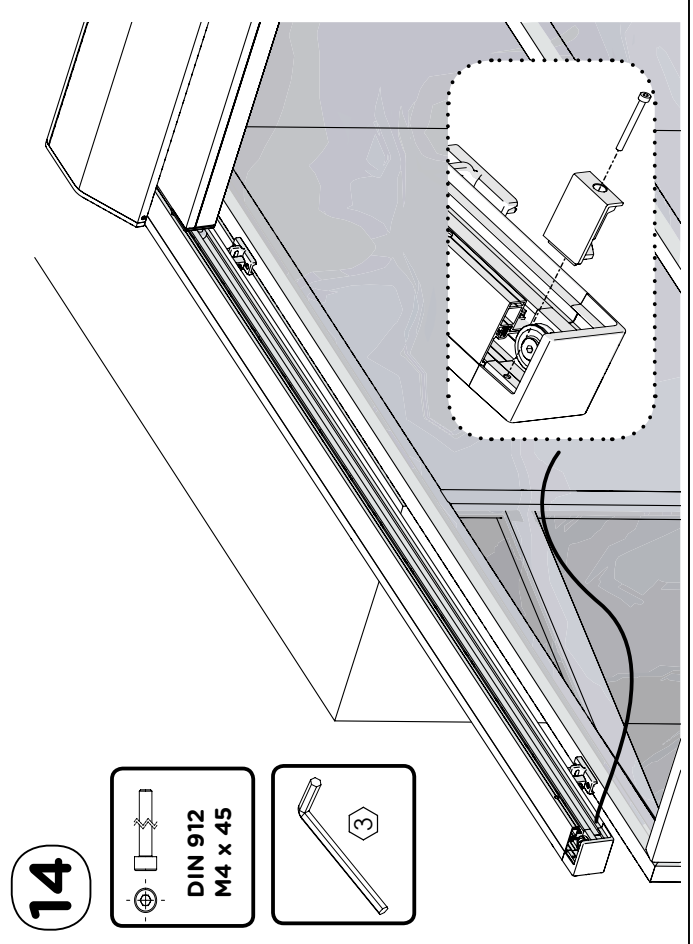

**14**

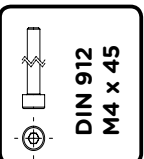

DIN 912  
M4 x 45

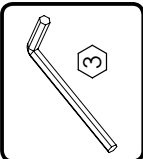

3

# COUPLED

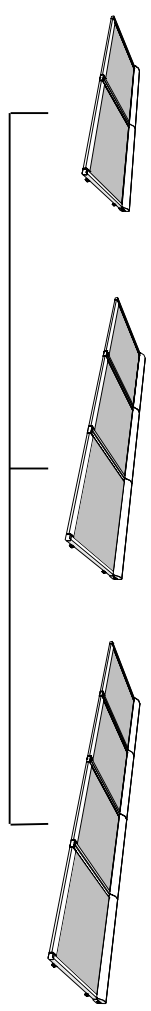

**!**  
SEPARATE BOXES



**3**

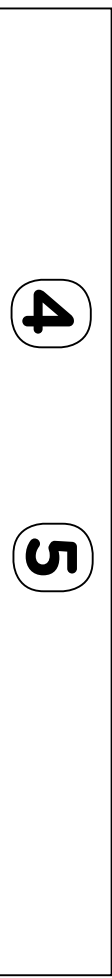
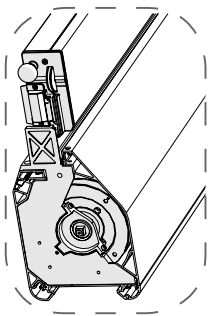
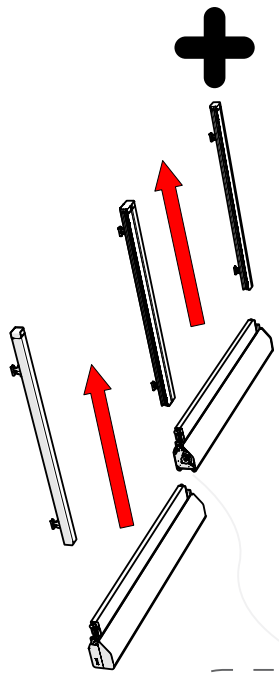

**6**

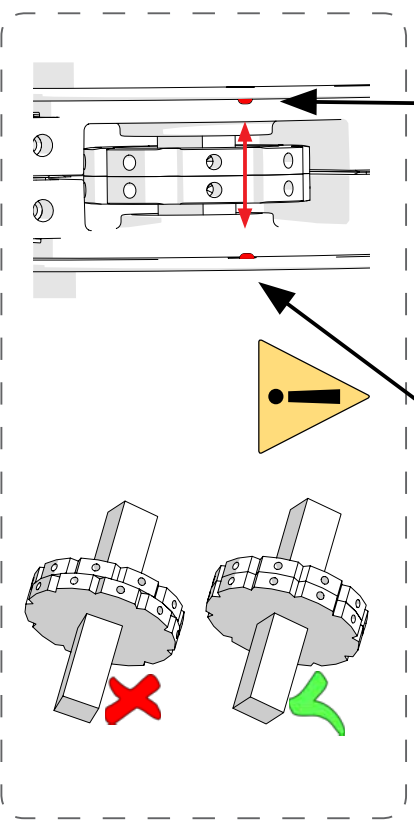
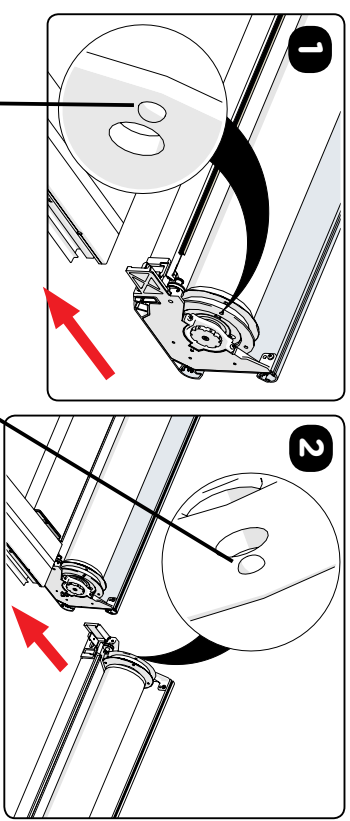

**1**

**2**

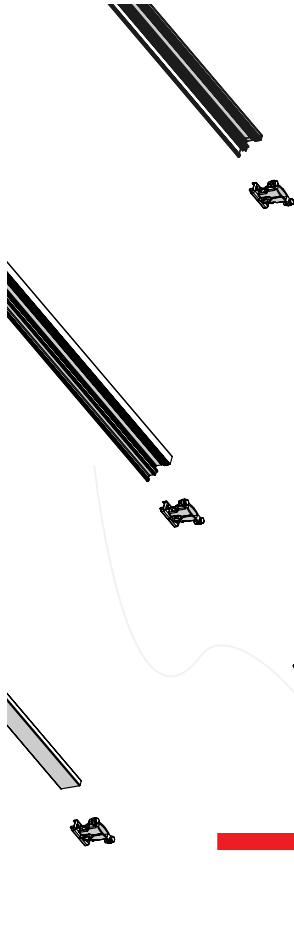

**LED CONNECTION**

LED module / Modul  
IO DIMMER  
VARIATEUR IO

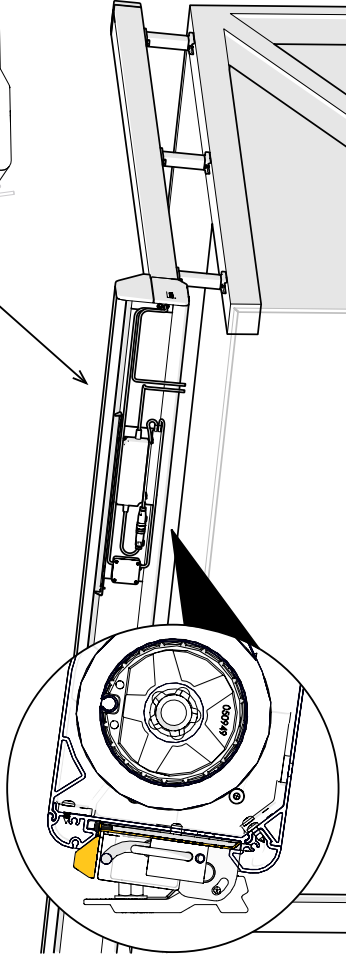
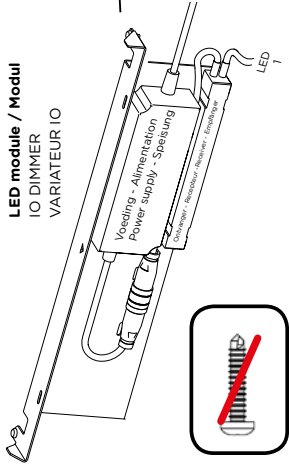

TYPE 1

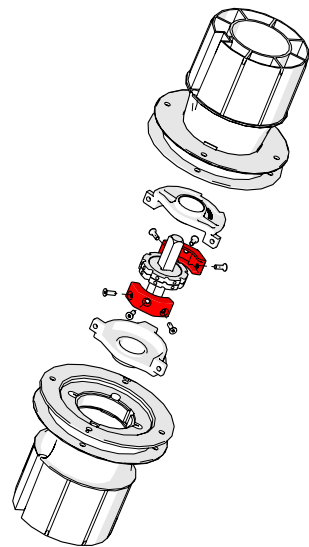
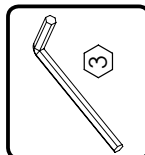
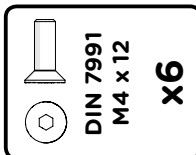
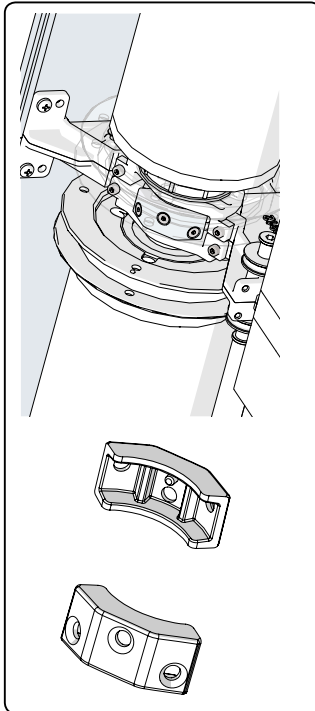
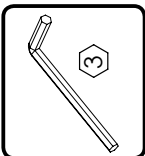
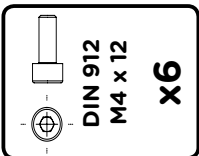
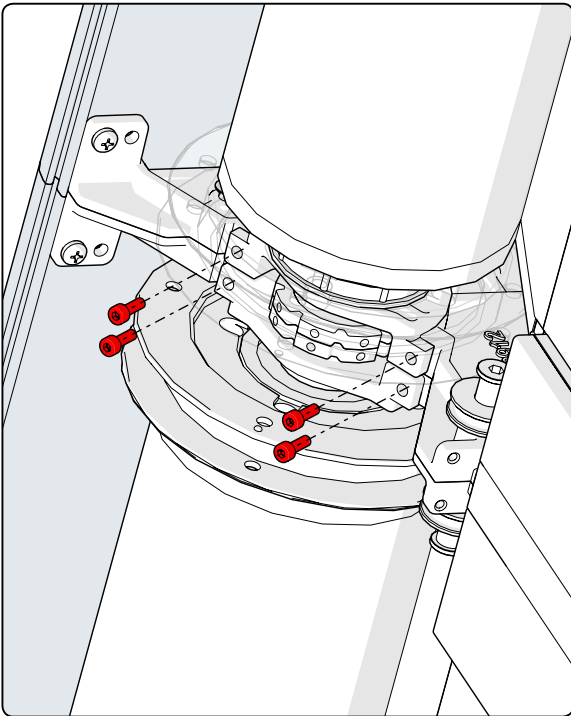
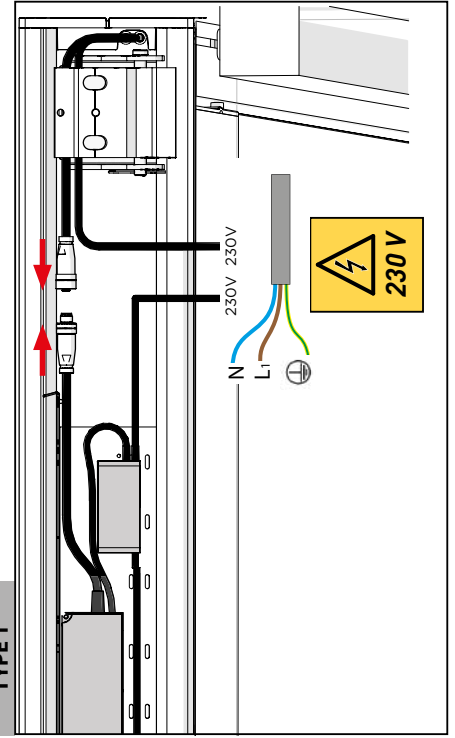

16

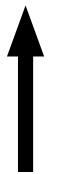

.....

8

7

## Veranda HRV80-ZIP-2P

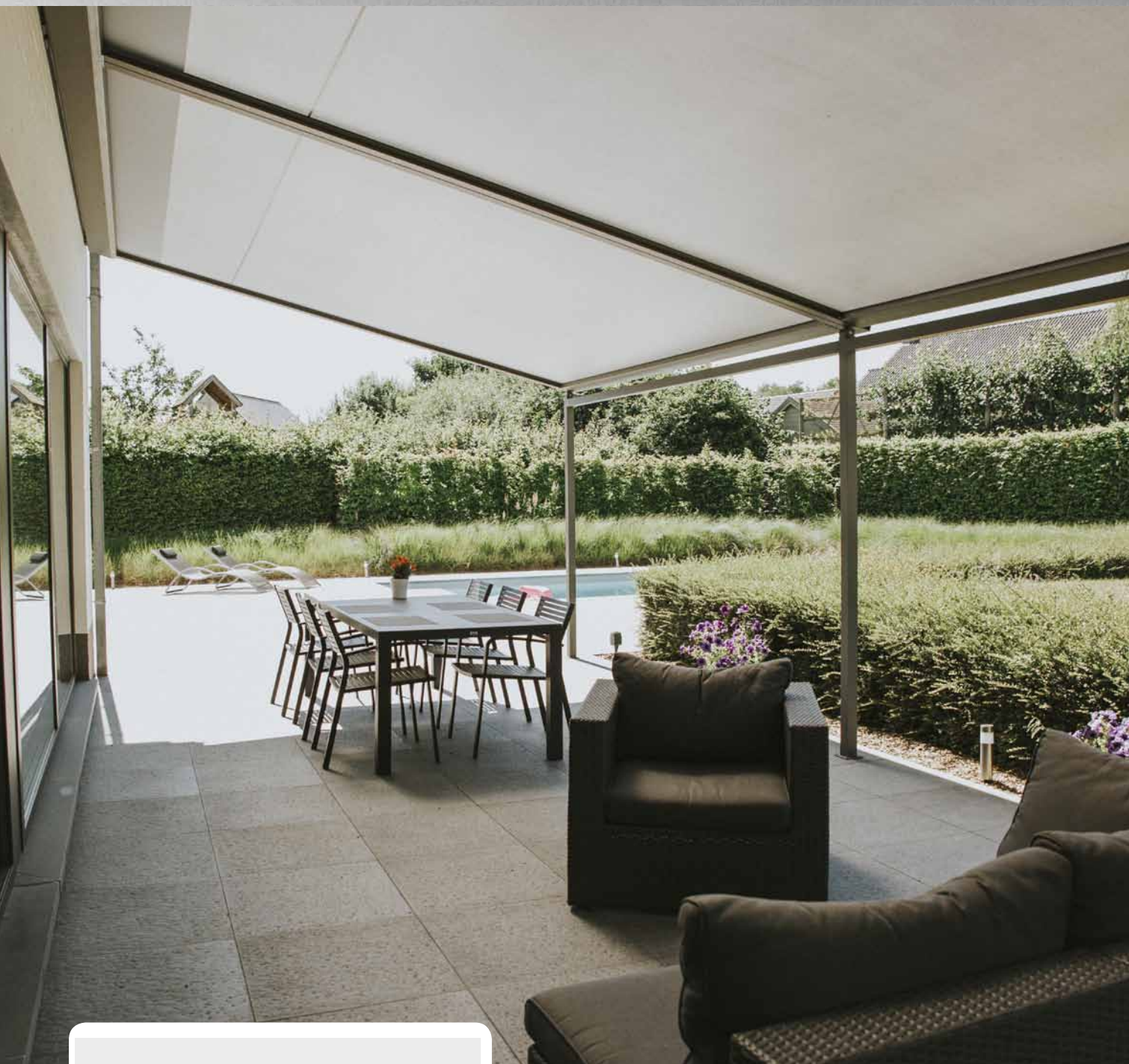

- ▲ Elegant thanks to a simple design
- ▲ Completely closed box, ensuring that the fabric colours will remain bright for many years
- ▲ Perfectly completes any terrace thanks to the flexible stand positioning
- ▲ The fabric remains taut thanks to the innovative ZIP system
- ▲ The compact box helps create a sophisticated appearance of the veranda
- ▲ Possibility to install LED lighting

**ISOTRA** *Quality*



**VERANDA HRV80-ZIP-2P (2-01532-0001)**

<b>position</b>	<b>item name</b>	<b>trade name - abbreviation 2</b>	<b>order number - abbreviation 1</b>
<b>10</b>	<b>Multi-piece sections – VERANDA</b>		<b>see Multi-piece sections - VERANDA HRV80-ZIP-2P</b>
11/230	Winding cylinder, diameter 110×1.25 mm	VRH 166	6-015978-0000
80	Reversing wheel for side board – 28×8 mm	VRH 094	6-014597-0000
140	Terminal board for HI-TEC cord complete	VRH 099	6-014607-0000
160	Foot 120×120	VRH 161	6-015972-0000
170	Fastening pin	VRH 162	6-015973-0000
180	Bolt plate	VRH 189	6-016022-0000
190	Connecting bracket	VRH188	6-016021-0000
200	Side cover Logo	VRH 163	6-015974-0000
210	Suspension 65×65 part 1	VRH 164	6-015976-0000
220	Suspension 65×65 part 2	VRH 165	6-015977-0000
240	Cylinder cap, diameter 110 mm – BLACK	VRH 167	6-015979-0000
250	Cord coiler, diameter 110 mm – BLACK	VRH 168	6-015980-0000
270	Cord coiler, diameter 110 mm – BLACK	VRH 174	6-015999-9004
280	Movable holder – BLACK	VRH 175	6-016000-9004
300	Cylinder cap, square – BLACK	VRH 176	6-016001-9004
310	Side board – LEFT	VRH 177	6-016002-9004
320	Reversing wheel pin – 10×34 mm	VRH 014	6-014598-0000
330	Side board – RIGHT	VRH 178	6-016003-0000
370	Lower section end piece – LEFT – BLACK	VRH 179	6-016004-9004
380	Wheel with fork for cord guiding HRV		6-019123-0000
400	HI-TEC cord 2.7 mm	VRH 021	6-014626-0000
410	Bracket lock	VRH 182	6-016008-0000
430	Screw 3.5×16 DIN 7982 C-H A2, countersink – cross-head	VRH 130	6-014674-0000
440	Screw 2.9×13 DIN 7982 C-H A2, countersink – cross-head	VRH 129	6-014738-0000
450	Screw 4.8×13 DIN 7982 C-H A2, countersink – cross-head	VRH 134	6-014734-0000
460	Allen head screw M6×30, DIN 912, A2		6-010408-0000
500	Screw M5×16 Zn DIN 965-Z, A2, countersink – cross-head		6-014338-0000
510	Allen head screw M4×12 A2 DIN 7991, countersink		6-016015-0000
520	Washer M10, DIN 125-1A, A2		6-014091-0000
530	Hexagon-head bolt M10×35, DIN 933, A2		6-016012-0000
550	Allen head screw M4×25, DIN 912, A2		6-016048-0000
570	Screw 4.2×13 DIN 7981 CH, A2, cup-head, cross-head	VRH 132	6-014640-0000
580	Bolt WN 1412 - K50×25, A2		6-016013-0000
590	Allen head screw M8×40 A2 DIN 7991, countersink		6-016014-0000
600	Allen head screw M4×16, DIN 912, A2	VRH 102	6-014736-0000
620	Screw M4×6 INOX A2, DIN 7985-H, cup-head, cross-head	VRH 105	6-014737-0000
<b>690</b>	<b>Motors (SOMFY) VERANDA</b>		<b>see Motors – VERANDA HRV80-ZIP-2P</b>
700	Wall bracket – part 1	VRH 185	6-016018-0000
710	Wall bracket – part 1	VRH 186	6-016019-0000
720	Wall bracket	VRH 183	6-016016-0000
730	Set screw M8×10 A4, DIN 916		6-013930-0000
740	Wall bracket pin		6-016017-0000
760	Flexible cotter DIN 11024		6-016020-0000
770	Allen head screw M5×20 A2 DIN 7991, countersink		6-016098-0000
790	Washer M5, DIN 125-1A, A2		6-002355-0000
800	Screw M5×10 INOX A2, DIN 933 (hexagon)		6-012977-0000
810	Screw 4.8×19 DIN 7982 C-H A2, cup-head, cross-head		6-013928-0000
<b>900</b>	<b>Guiding – rail – LEFT</b>		<b>see Guiding – rail – LEFT</b>
<b>910</b>	<b>Guiding – rail – RIGHT</b>		<b>see Guiding – rail – RIGHT</b>

**Multi-part sections – VERANDA HRV80-ZIP-2P (3-03390-0085)**

position	item name	trade name - abbreviation 2	order number - abbreviation 1
10/10	Section BOX – rear	VRH 147	6-015958-0000
10/20	Section BOX – lower	VRH 148	6-015959-0000
10/30	Lower section LED – 7.0m	VRH 149/1	6-015960-0007
10/130	Lower section	VRH 158	6-015969-0000
10/150	Lower section – cover	VRH 159	6-015970-0000
10/340	Profile for fabric run-on	ZPH115-1	6-013986-0000
10/350	Brush for upper box – BLACK	VRH 024	6-014706-9004
10/390	Section BOX – cover	VRH 181	6-016007-0000
10/400	Section Stand / Cross bar – 65x65	VRH 160	6-015971-0000

**Guiding – rail HRV80-ZIP-2P – left (2-01533-PU11L)**

position	item name	trade name - abbreviation 2	order number - abbreviation 1
900/100	Guide rail cap – left	VRH 155	6-015966-0000
900/150	Guide rail end piece – left	VRH 151	6-015962-0000
900/700	Section Stand / Cross bar – 65x65	VRH 160	6-015971-0000

**Guiding – rail HRV80-ZIP-2P – right (2-01533-PU11P)**

position	item name	trade name - abbreviation 2	order number - abbreviation 1
910/40	Guide rail section	VRH 150	6-015961-0000
910/90	Guide rail section – lock	VRH 154	6-015965-0000
910/110	Guide rail end piece – right	VRH 156	6-015967-0000
910/120	Guide rail cap – right	VRH 157	6-015968-0000
910/160	PIN of side board dia. 10	VRH 152	6-015963-0000
910/170	Wheel for rope	VRH 153	6-015964-0000
910/360	Spring of guide rail ZIP SC800	ZPH147	6-013992-0000
910/420	Guiding section SC800 for zip v3	ZPH145	6-014155-0000

**Motors – VERANDA HRV80-ZIP-2P (2-00530-0008)**

position	item name	trade name - abbreviation 2	order number - abbreviation 1
690/310	Carrier LT50/60 HI – dia. 110 mm	VRH 170	6-015982-0000
690/320	Adapter – LT50 – tube dia. 61 mm	VRH 003/1	6-014898-0000

**Weight**

box		2 lateral guides		connecting rail		stand design	
length	weight	length	weight	length	weight	length	weight
1.0 m	approx. 25 kg	1.0 m	approx. 5 kg	1.0 m	approx. 4 kg	1.0 m	/
1.5 m	approx. 35 kg	2.0 m	approx. 10 kg	2.0 m	approx. 8 kg	2.0 m	approx. 25 kg
2.0 m	approx. 45 kg	3.0 m	approx. 15 kg	3.0 m	approx. 12 kg	3.0 m	approx. 37.5 kg
2.5 m	approx. 55 kg	4.0 m	approx. 20 kg	4.0 m	approx. 16 kg		
3.0 m	approx. 65 kg						
3.5 m	approx. 75 kg						
4.0 m	approx. 85 kg						

Veranda HRV80-ZIP-2P, width 1.5 metres, projection 2 metres and height 2 metres weighs approx. 90 kg.

# Veranda HRV80-ZIP-2P

## Basic product specification

### Section BOX

Material: extruded aluminium.

Wall thickness: 2.5 mm.

Dimensions: 245 mm × 175 mm.

Consists of two parts:

- removable tapered upper section or cover,
- fixed bottom section.

The fabric guiding section is attached to the fixed section that leads the fabric from the box.

The cover includes a built-in brush.

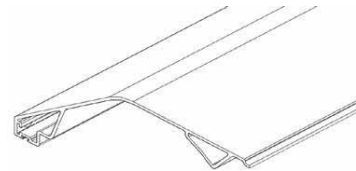
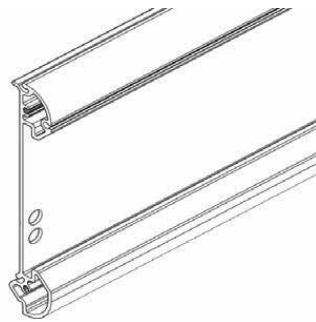
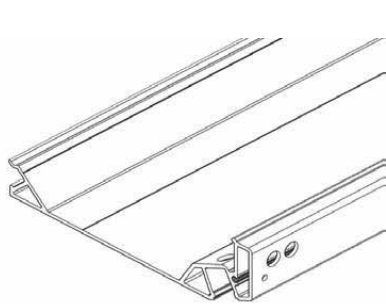
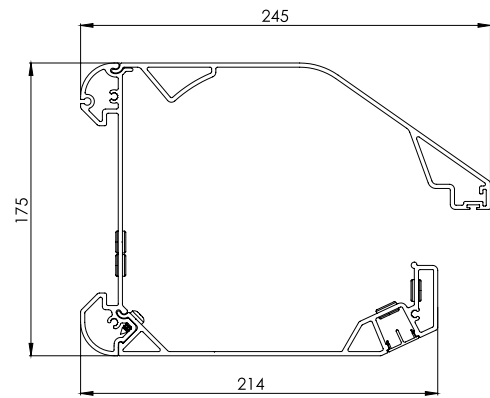

**Bottom section up to 4 m**

**Bottom section over 4 m**

**Bottom section - cover**

### Bottom section

Material: extruded aluminium.

Wall thickness: basic section 4 mm.

Closing section 2.5 mm.

Function:

- The basic section is equipped with a groove, into which fabric can be attached.
- The closing section is fitted on the basic section.
- It moves in the lateral guide grooves on special sliding blocks.

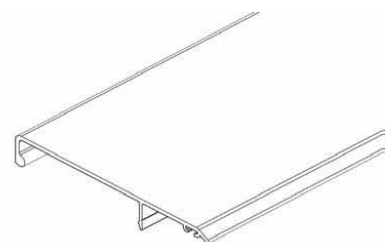
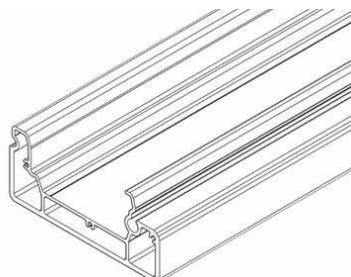
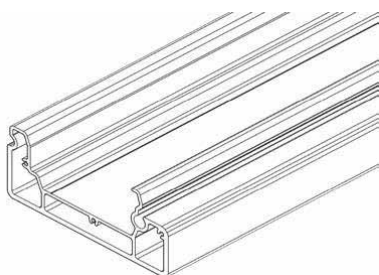
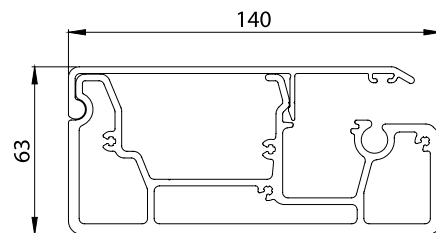

**Bottom section up to 4 m**

**Bottom section over 4 m**

**Bottom section - cover**

### Winding cylinder

Material: galvanised-steel tube with a groove for attaching the fabric.

Function: unwinding and winding of the fabric.

Up to the width of 4000 mm - the shaft diameter is 85 mm.

From the width of 4001 mm - the shaft diameter is 110 mm.

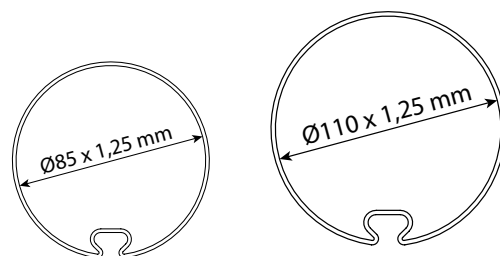

### Guide rails STANDARD

Material: extruded aluminium.

Wall thickness: 1.5 mm.

Two types:

- Lateral guides: installed on the outside, with a groove on one side only.
- Connecting rails: installed in the middle, with grooves on both sides.

The sections have recesses, into which the lateral cover support pins fit and through which the cords are guided.

The aluminium end covers have the same colour as the frame.

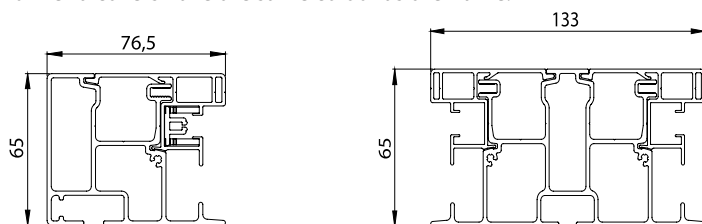

### Guiding channels XL

Are standardly delivered from 4001mm height, including covers.

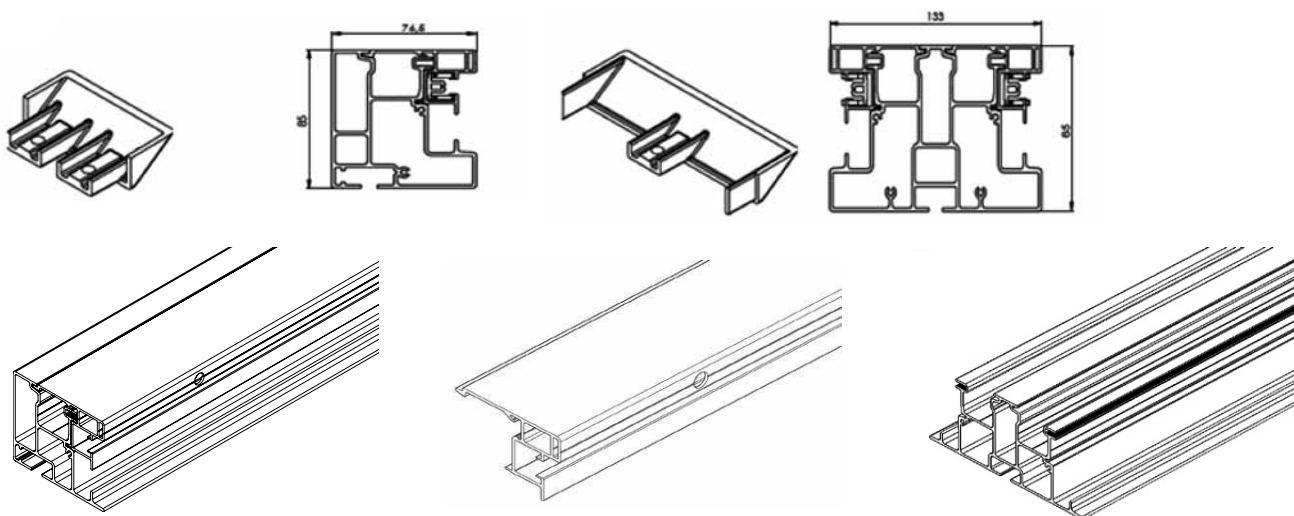

Guide rail section

Guide rail section – closing

Guide rail section – double

### Zipper-type guide section

Material: extruded PVC clip section.

Function: Absorption of the zipper section on the fabric, making it taut using stainless springs.

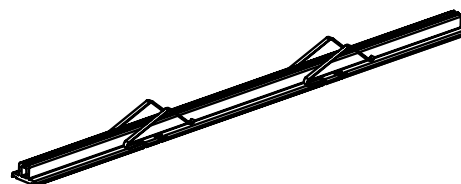

### Clip-On/Clip-Off section

Material: extruded PVC clamps.

Function: Attaching the fabric in the groove without the need to use screws, so that the fabric could be removed moving it to the front instead of pushing it sideways.

Clamp diameter: 3 mm.

Advantage: fast and easy fabric replacement.

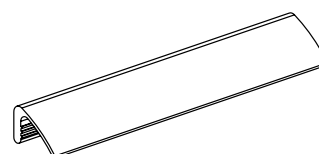

### Stands

Material: extruded aluminium, powder-coated.

Wall thickness: 2 mm.

Dimensions: 65 mm × 65 mm.

Function:

- The stand is equipped with pins to be used for placing the cross bar.
- The stand with the flange is to be attached to a foot.

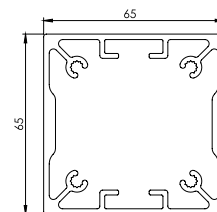

### Cross bar

Material: extruded aluminium, powder-coated.

Wall thickness: 2 mm

Dimensions: 65 mm × 65 mm

The installation of the stands is facilitated thanks to the openings.

The bar is covered on both ends.

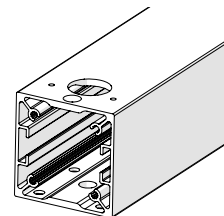

### Side board

Material: cast aluminium, powder-coated.

Colour: same as the frame colour.

There are two types of brackets: side and connecting.

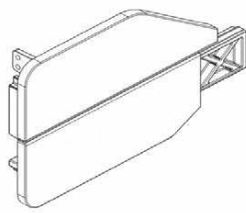
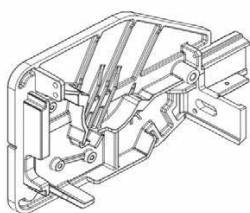

**Side board LEFT / RIGHT**

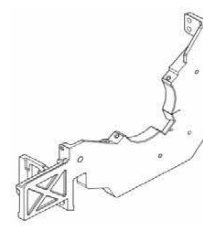
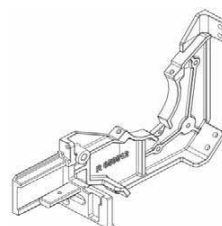

**Central side board – LEFT / RIGHT**

### Sliding blocks

Material: injection-moulded plastic

Function:

- Connecting the extension pole and guide rails, fitted with a sliding surface that meshes into the running surface of the guide rail.
- They are screwed into the left and right of the end of the bottom section.

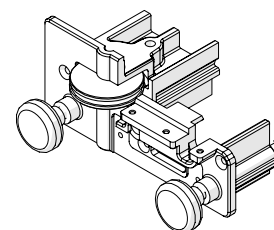

### Guide rail covers

Material: cast aluminium, powder-coated.

Colour: same as the frame colour.

Function:

- Covering the guide rails
- Guiding the cord

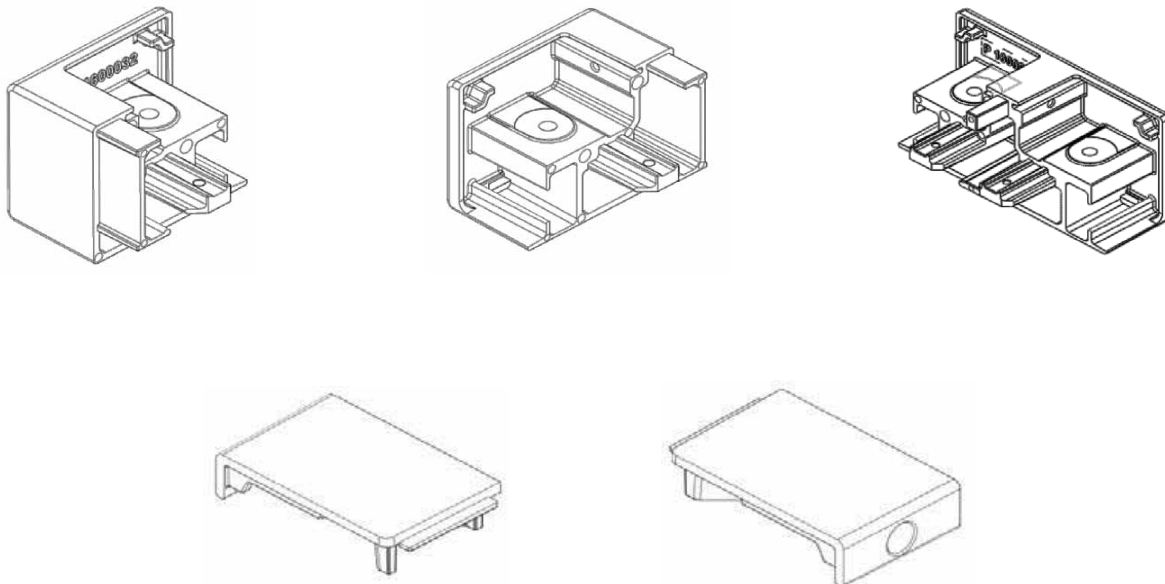

### Tension system

Material: castors, axles, etc. are made of non-corroding materials.

Function: The fabric and bottom section can be kept under constant tension using a spring, castors and  $\varnothing 2.7$  mm cord.

### Connecting parts

Material: Corrosion-resistant material.

Function: Pairing two parts of fabric.

Adjustable in 8 steps.

Note: It is possible that the bottom sections will not simultaneously extend and retract to the fullest, as there may be some slackness in the connection. It is therefore recommended for coupled awnings to place the motor to the widest part.

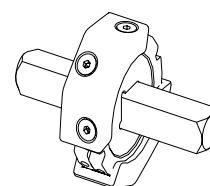

### Foot

Material: stainless steel, powder-coated.

Wall thickness: 5 mm.

Dimensions: 120 mm  $\times$  120 mm / 120mm  $\times$  92,5mm.

The foot can be anchored to the substrate using the provided openings.

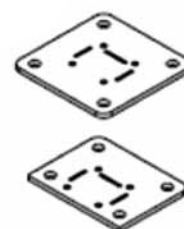

### Articulated joints

Material: aluminium, powder-coated.

Consists of two parts bolted together.

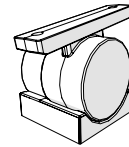

### Wall bracket part 1

Material: stainless steel with a spindle and retainer rings.

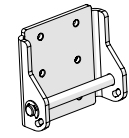

### Wall bracket part 2

Material: aluminium, powder-coated.

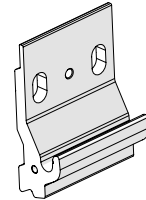

### Stand connecting bracket

Material: stainless steel with two clamps and socket head screws.

### Securing plate of the wall bracket:

- Material: stainless steel (RVS)
- Function: the box is hung on the wall bracket part 2 using the bracket part 1. Then, to the wall bracket part 2, the securing plate is attached with a M8 screw, so that the axis of the bracket part 1 cannot move upwards.



### Technical options

Minimum width per 1 part:	1.5 m
Maximum width per 1 part:	6 m
Maximum projection (U):	5 m
Maximum fabric area:	25 m <sup>2</sup>
Maximum clearance (H2):	2.9 m

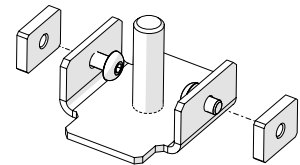

### Technical options – verandas coupling

Type	Maximum width (m)								Max. area	Number of verandas	Number of motors
	1,5	3	4,5	6	8	12	14	16			
Type 1		1 veranda							25 m <sup>2</sup>	1	1
Type 2		2 verandas							40 m <sup>2</sup>	2	1
Type 2		2 verandas							50 m <sup>2</sup>	2	2
Type 3		3 verandas							65 m <sup>2</sup>	3	2
Type 4		4 verandas							80 m <sup>2</sup>	4	2

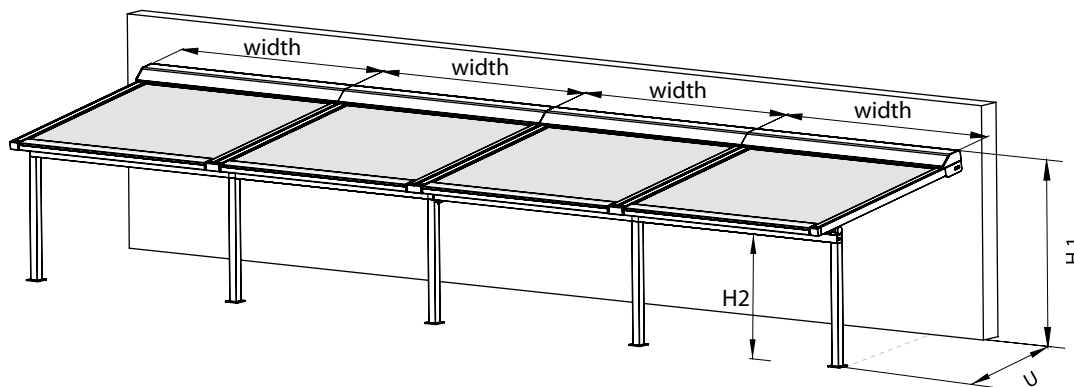

H1 – Height

H2 – Clearance

U – Projection

Note: In coupled systems, the intermediate stands are always fixed directly below the central guide rail.

### Controls

The installation is driven by a tubular motor 230 V (50 Hz) located on the far left or far right, as necessary. Control location when viewed from the outside. The standard supply includes the Sunea IO motor type without push buttons, being controlled by an IO transmitter, a 3-metre supply cable, and a wall-mounted, single-pole switch.

### Optional:

- 3-, 5- or 10-metre supply cable.
- The distance can be increased by using a connecting box.
- No switch.
- **Motor with automatic pre-setting; the shade will always fully retract (Orea WT):**
  - no control push-buttons; the end positions will be set by a cable and regulating set,
  - parallel connection (number acc. to the switch type),
  - 3-metre supply cable,
  - wall-mounted, single-pole switch.
- **Motor with a built-in RTS receiver (Orea RTS):**
  - 3-metre supply cable – a 5 or a 10-metre cable can also be used,
  - wall-mounted RTS transmitter – optionally without the wall-mounted RTS transmitter.
- **Motor with a built-in IO receiver (Sunea IO):**
  - 3-metre supply cable – a 5 or a 10-metre cable can also be used,
  - wall-mounted IO transmitter – optionally without the wall-mounted IO transmitter.

The RTS and IO motors are supplied with activated options for “back shutdown” and “reduced closing force”.

### Accessories:

- Relay boxes,
- Controls using the wind/sun sensor,
- Time switches,
- Remote control,
- and others...

The middle positions cannot be equipped with a motor. They are always coupled with a side veranda that has a motor.

One prop in the middle can only be combined with a double centre slat.

If there are two simple slats in the middle, then there must be two props next to each other.

## VERANDA HRV80-ZIP - 1P

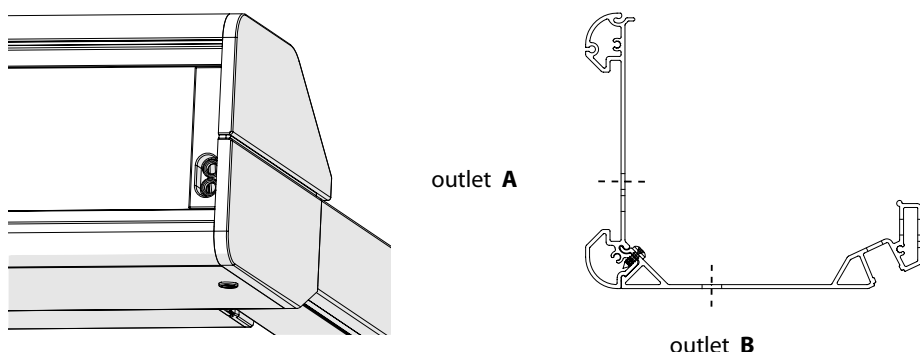

### 1. General information

To a great extent, the HRV80-ZIP-2P veranda screen allows regulating the sunlight penetration into a room and thus avoids unpleasant high amount of light and heat. The fabric is protected when rolled in the box which is closed by bottom section in the fully retracted position. The box is attached to a wall behind the screen using wall and fixing brackets. This system is designed to easily overcome any small tolerances of roof construction. The whole system is made from corrosion-resistant materials.

Veranda HRV80-ZIP-2P is equipped with a zipper system that ensures the fabric stays properly taut in every position of the bottom section and avoids fabric slipping out from the guide rails. The individual parts of the fabric are always fitted with a zipper on both the left and right side, while the thicker part locks with the plastic zipper section inserted in an aluminium guide rail.

The HRV80-ZIP-2P system consists of the following parts:

- Box with an easily removable, motor-driven winding cylinder,
- Fabric with a zipper, wound in the box,
- Guide rails for easy connection of the zipper section,
- Bottom section with a spring and cords that keep the fabric taut, plus water draining,
- Stands on which the sections rest,
- Frontal cross bar that ensures horizontal connection of the stands,
- Zipper guiding and tightening system.

## Motor controls

### Types of motors (SOMFY) for Veranda

item name	trade name - abbreviation 2	order number - abbreviation 1
Motor OREA 50 WT 40/17	MR 096/40	6-001550-0040
Motor OREA 60 WT 55/17	MR 096/55	6-001550-0055
Motor OREA 60 WT 70/17	MR 096/70	6-001550-0070
Motor OREA 60 WT 85/17	MR 096/85	6-001550-0085
Motor OREA 50 RTS 40/17	MR 092/40	6-011171-0040
Motor OREA 60 RTS 55/17	MR 092/55	6-011171-0055
Motor OREA 60 RTS 70/17	MR 092/70	6-011171-0070
Motor OREA 60 RTS 85/17	MR 092/85	6-011171-0085
Motor Sunea 50 io 40/17	MR 134/40	6-012559-4017
Motor Sunea 60 io 55/17	MR 134/55	6-012559-5517
Motor Sunea 60 io 70/17	MR 134/70	6-012559-7017
Motor Sunea 60 io 85/17	MR 134/85	6-012559-8517

## Types of motors (BECKER) for Veranda HRV80-ZIP-2P

item name	trade name - abbreviation 2	order number - abbreviation 1
Motor BECKER 50 E 40/17	17BE	6-017852-0040
Motor BECKER 60 E 60/17	17BE	6-017852-0060
Motor BECKER 50 E 40/17	BC40	6-017852-0040
Motor BECKER 60 E 60/17	BE60	6-017852-0060
Motor BECKER 60 E 70/17	BE70	6-017852-0070
Motor BECKER 60 E 120/11	BE120	6-017852-0120
Motor BECKER 50 C 40/17	16BC	6-017853-0040
Motor BECKER 60 C 60/17	16BC	6-017853-0060
Motor BECKER 50 C 40/17	BC40	6-017853-0040
Motor BECKER 60 C 60/17	BC60	6-017853-0060
Motor BECKER 60 C 70/17	BC70	6-017853-0070
Motor BECKER 60 C 120/11 PLUS	BC120	6-018886-0120

Note: E=electronic motor, C=radio motor

## 2. Installation options

This type of sun screen can only be installed to a wall. The rear side of the box is equipped with supporting brackets that allow attaching the box to already installed brackets. Following the box installation, the stands (with the cross bar) are to be placed to the front part and connected to the sun screen using articulated joints. The stands are anchored in or on the substrate. If water-proof fabric is used and the minimum angle is observed, water will drain over the front rail.

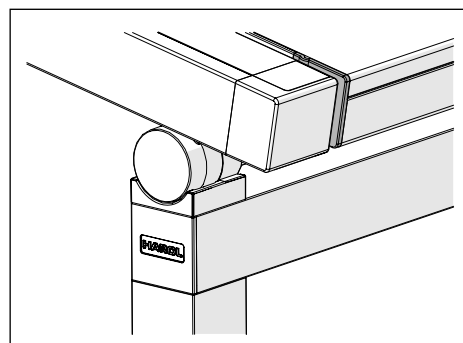
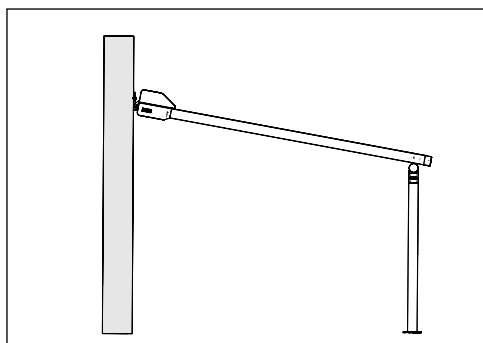
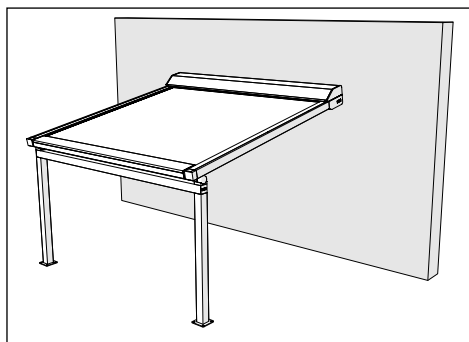

### 3. Installation

Note: Ensure perpendicularity of installation at all times, otherwise fabric wrinkling will occur. The maximum overhang is 1000 mm. Make sure the box and the bottom profile can always be opened and that the mechanical parts inside are accessible at all times. Should you fail to follow this rule, ISOTRA cannot be held responsible for the cost of demolition work!

#### 3.1 Wall bracket (standard)

For wall mounting.

Width: 90 mm, with two oval M12 openings.

The front side features a hook that supports the spindle (wall bracket, part 2).

The number of wall brackets supplied always depends on the type of sun screen.

Two brackets per one part of the box are supplied.

Fasteners must always be selected depending on the type of wall material.

Must be ordered independently: Additional wall bracket on the box. Another wall bracket between the box and the wall can be supplied for greater box widths.

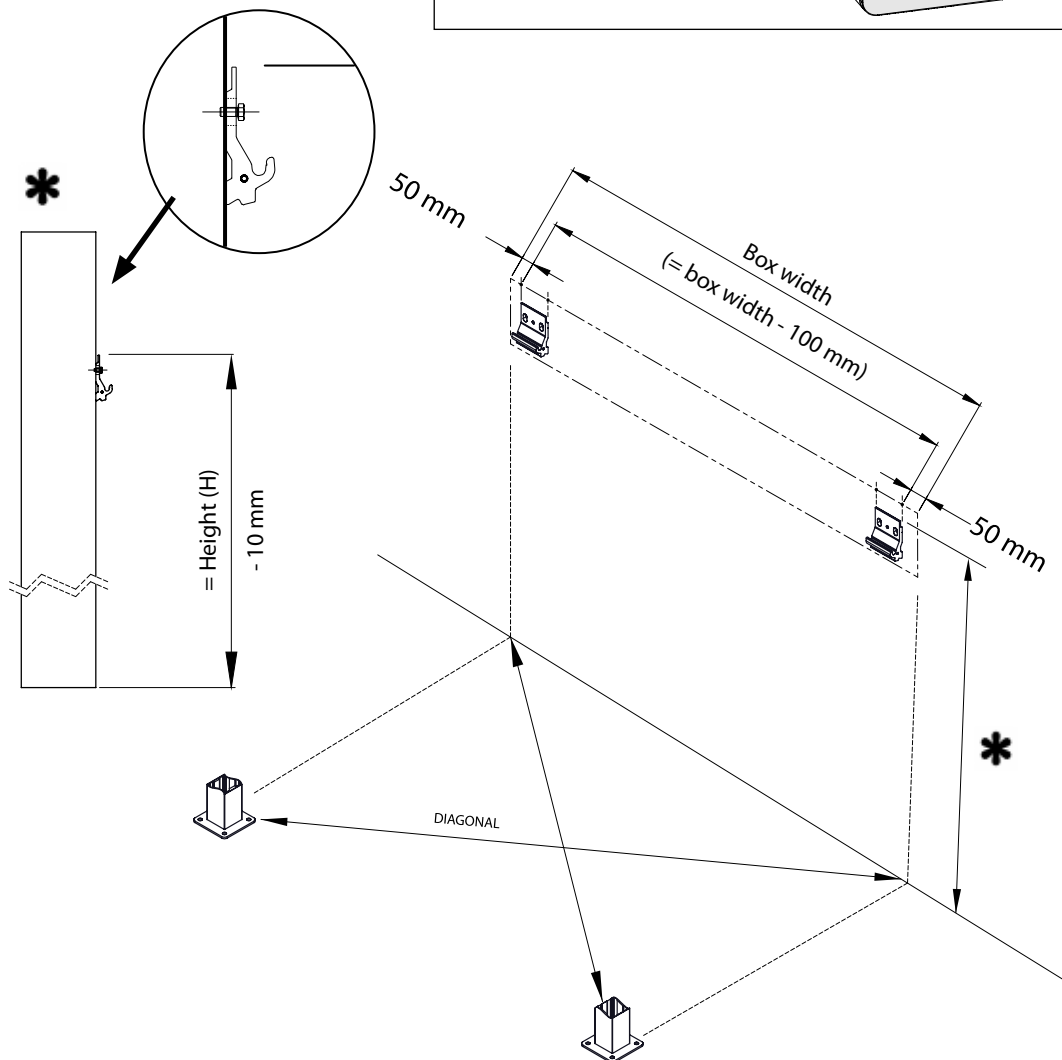
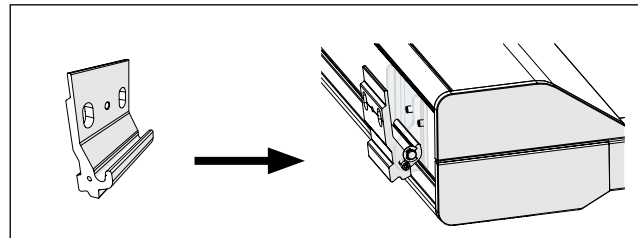
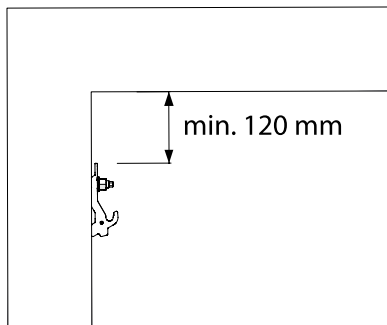
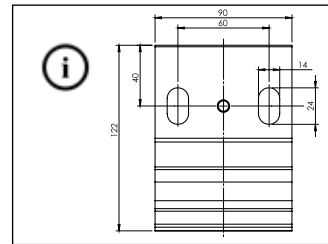

#### 4. Measuring

Guidelines for correct measuring

Ensure the system is perfectly parallel and squared. An accurate measurement ensures a quicker and easier assembly.

Ensure exact levelling of the system.

Ensure that the foundation is sufficiently solid to install the foot supports.

Be careful with relatively weak walls: the standard fixings are not part of the supply. Seek advice from your supplier of connecting material.

Overall width = from the outer part of the left bracket to the outer part of the right bracket. The stand structure has the same width as the box.

Projection (U): depth measured horizontally from the wall to the front side of the vertical stand.

The final position of the bottom section can be set flush with the end of the guide rail cover.

Clearance (H2) = height in the front part between the stands, measured from the floor (zero level) to the lower part of the horizontal cross bar.

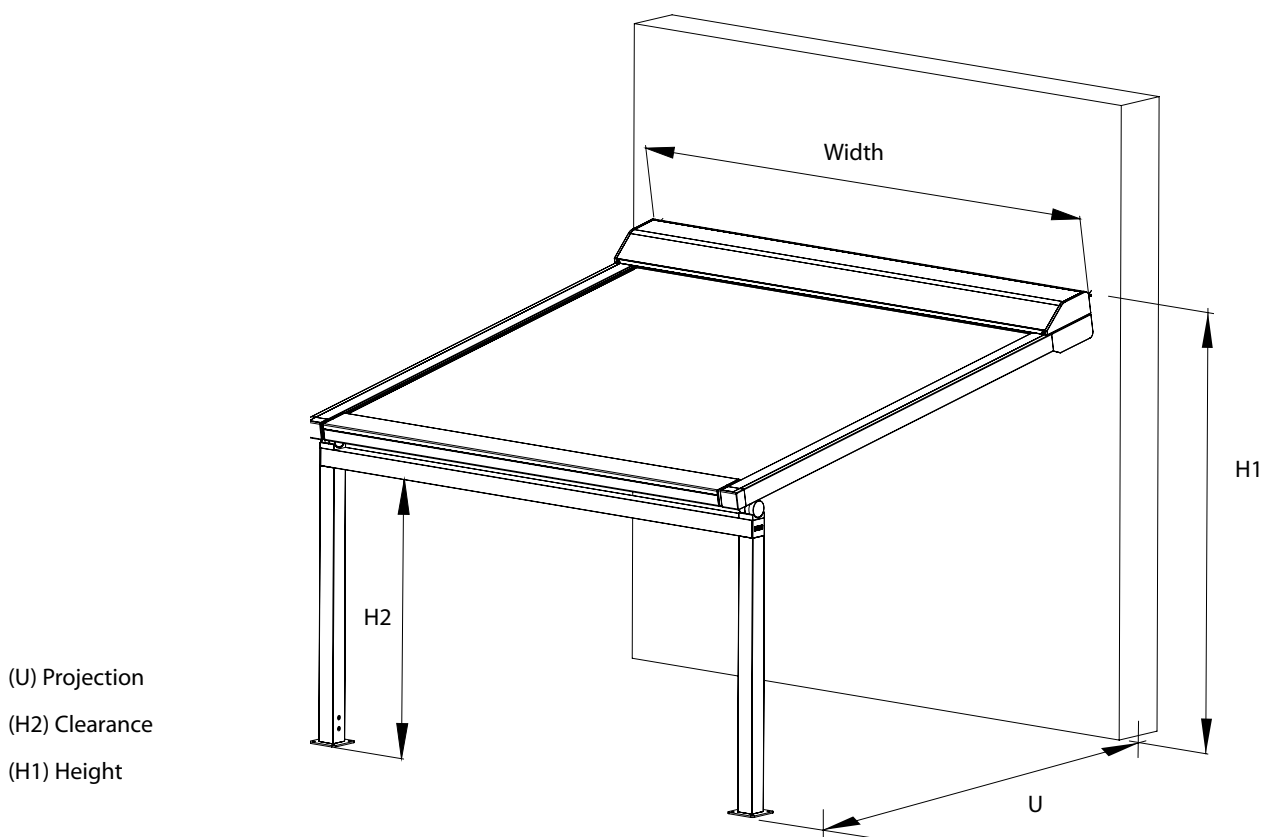

Note: In the standard version, the stand structure has the same width as the veranda.

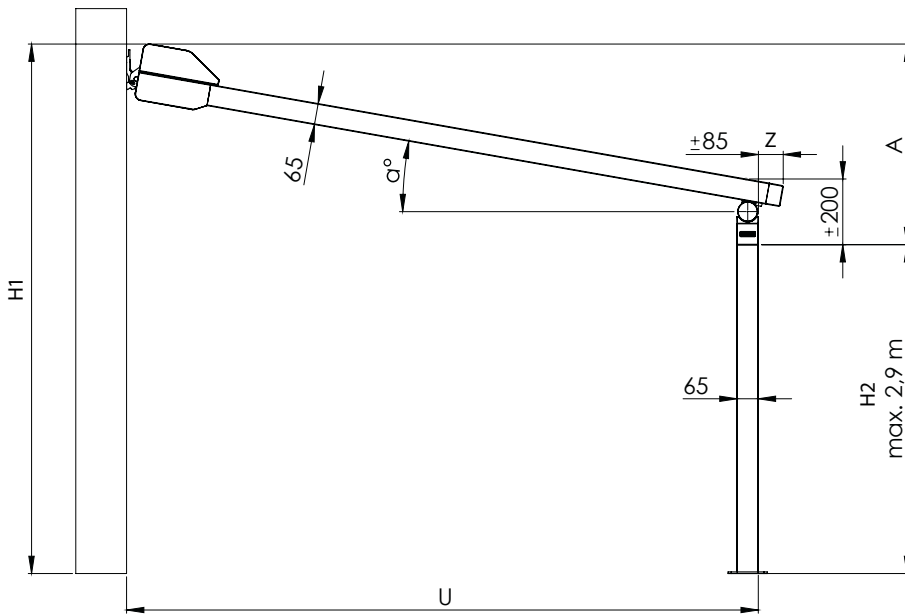

- A: Inclination (mm) =  $H1 - H2$
- B: Width
- H2: Clearance (max. 2.9 m)
- H1: Overall height incl. box
- U: Projection
- U': Overall projection with overlap =  $U + Z$
- X: Stands inwards
- Y: Stands outwards
- Z: Overlap Standard 85mm

**MAXIMUM INCLINATION = 30°**

\* min. 10° with LED lighting

**INCLINATION (A) in MM**

	Inclination angle ( $\alpha$ )	8°	10°	14°
projection (U)	1500	490	535	645
	2000	560	620	770
	2500	630	705	895
	3000	700	802	1020
	3500	770	890	1145
	4000	840	978	1270
	4500	910	1065	1395
	5000	980	1155	1520

Minimal angle of inclination

Soltis 86 / Soltis 92  
without LED lighting 80  
with LED lighting 10

Fabric Infinity:  
The minimum gradient of slope for Infinity fabric is 14°  
The veranda with extension  $\geq$  3200 mm is covered with horizontal stitching.

**CAUTION. CHECK WHETHER THE STRUCTURE INCLINATION IS GREATER THAN OR EQUAL TO THE VALUE SPECIFIED IN THE ABOVE TABLE IN ORDER TO ENSURE GOOD WATER DRAINING ON THE FRONT SIDE.**

If the system inclination (A) is insufficient for good water draining, ISOTRA only guarantees the product function as sun screen; in this case, complaint cannot be filed against the company in case of a breakdown or damage caused by poor water draining.

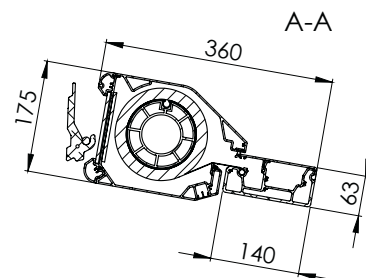
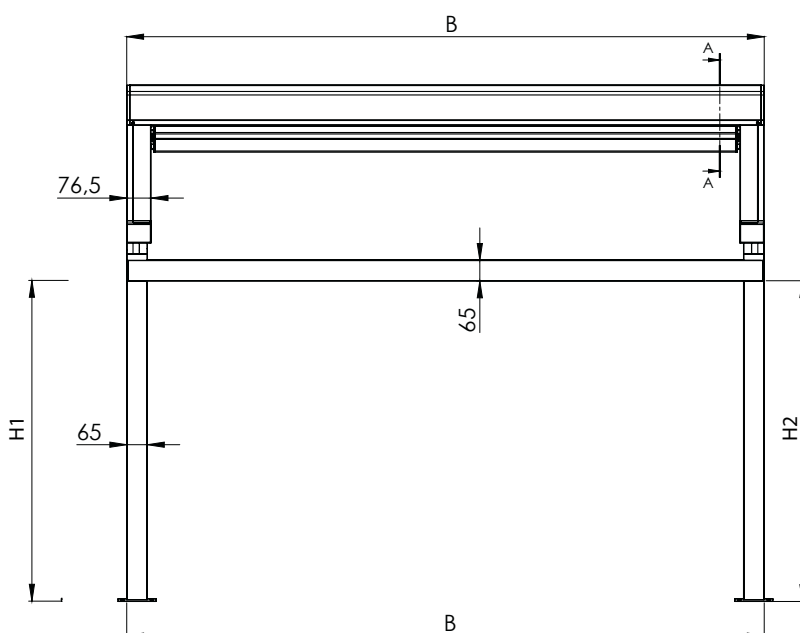

OPTIONS

OPTION 1  
stands inwards

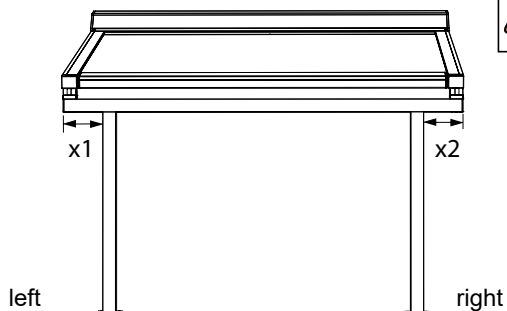
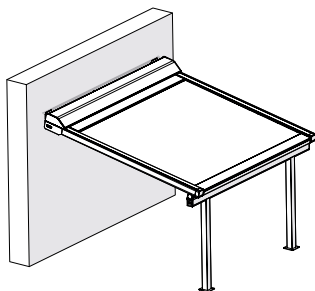

$x(1)$  : Min. 65 mm  
Max. 500 mm

OPTION 2  
stands outwards

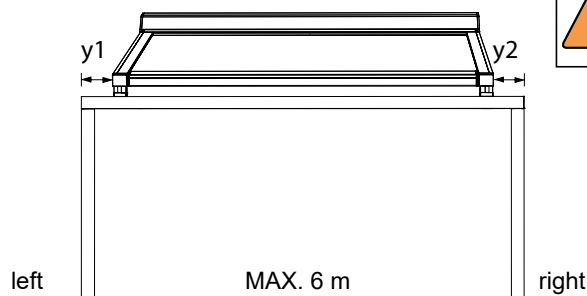
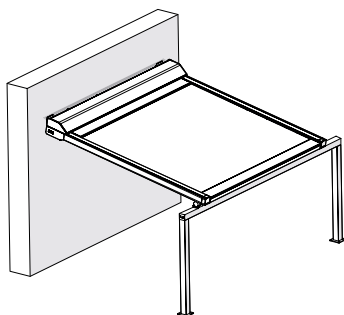

$y(1)$  : Min. 65 mm  
Max. 500 mm

OPTION 3  
overhang

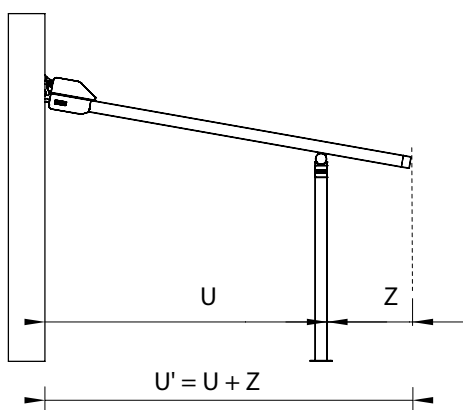
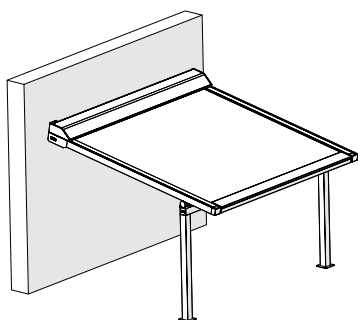

$Z$  : Min. 85 mm  
Max. 1000 mm

caution!  
the lower section can extend lower than the clearance (G)

$U' = \text{MAX. } 5 \text{ m}$

Make sure it is possible to open the box and lower section at all times to provide access to the mechanical parts inside. If this rule is not followed, ISOTRA cannot be held responsible for the cost of demolition work!

## OPTIONS

### Wall insert

If necessary, it is possible to place a wall insert to the gap between the box and the wall to create a water-tight seal. Aluminium sections are placed on each side and complemented with cover sheets. A rubber band is inserted to the section where it touches the box.

- tilting: can be easily removed to access the box
- has the same colour as the rest of the structure

### Wall insert – wall section, part 1

Material: extruded aluminium, powder-coated

Wall thickness: 2 mm



wall section, part 1

### Wall insert – wall section, part 2

Material: extruded aluminium, powder-coated

Wall thickness: 2 mm

With rubber band



Rubber

wall section, part 2

### Wall cover

Material: aluminium, powder-coated

The sheet is to be formed during the installation to attain the right angle



Side wall cover



Wall cover

### Side wall cover

Material: stainless steel

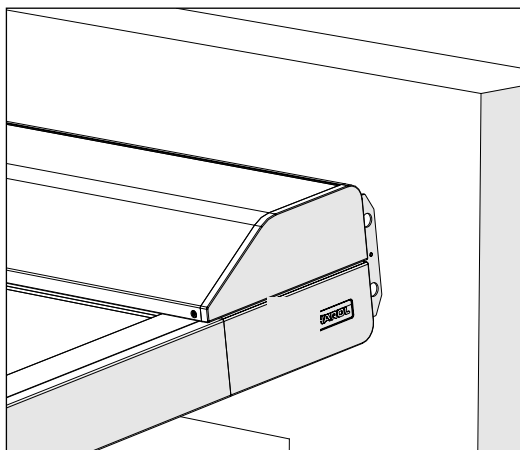

Standard

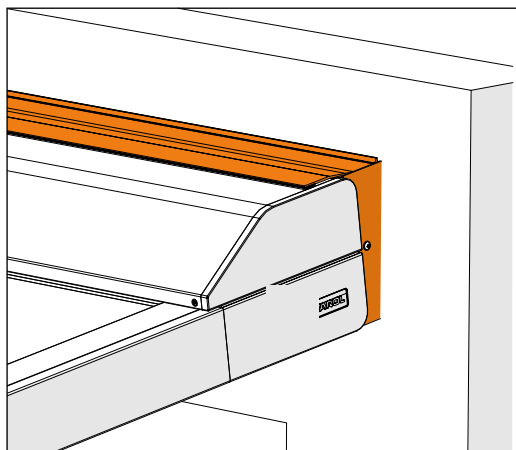

Wall cover

**\* If attached to the wall: must be packed**

Installation of side cover

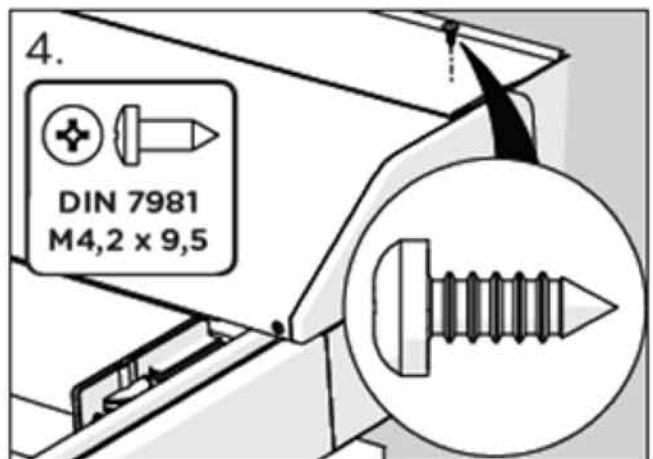
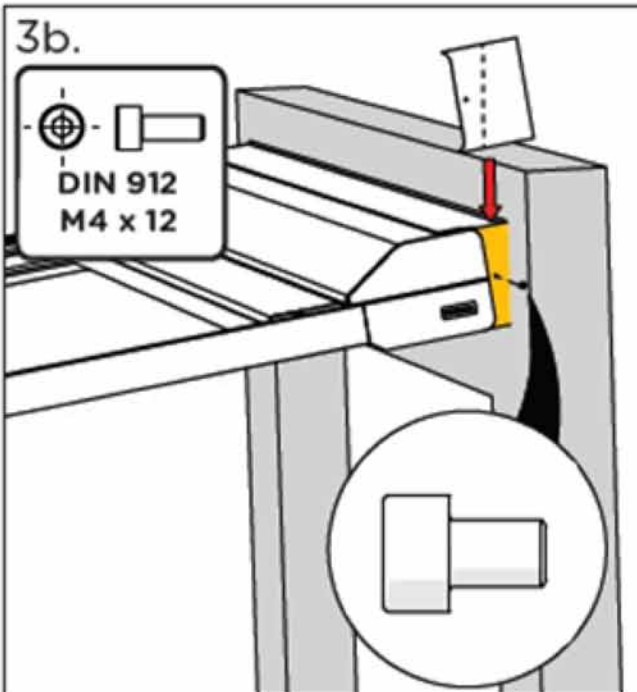
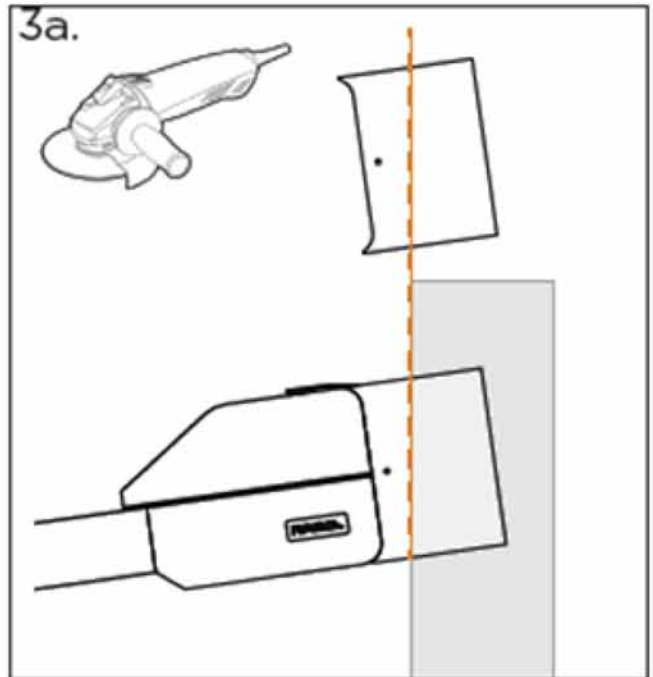
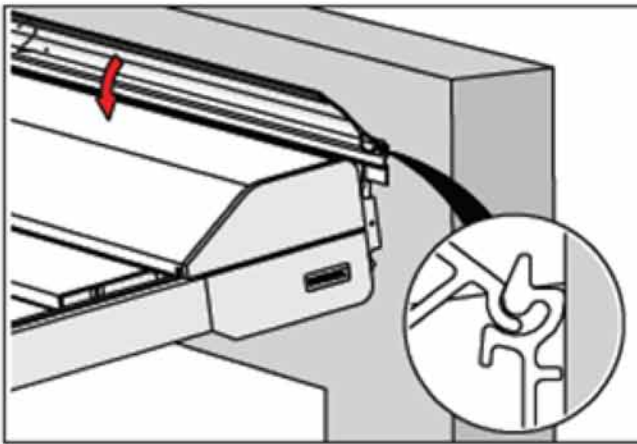
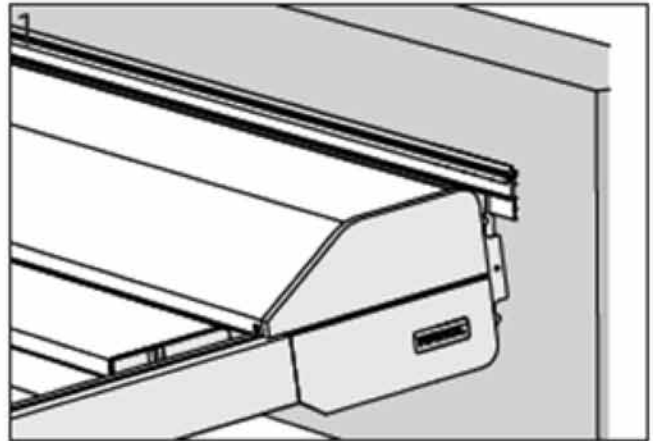
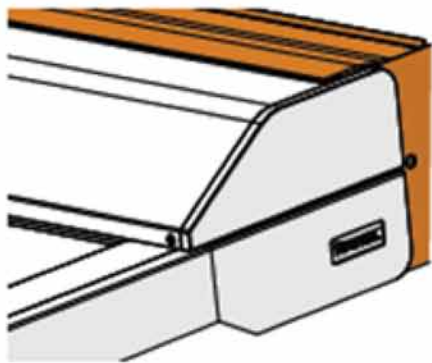

## 5. Design

The fabric has zippers on the sides, and if the guide rails are properly installed, these zippers ensure the fabric remains taut in any position of the bottom section thanks to the strain between the zipper and the guide rails.

Cracking may be heard when retracting the screen, which is caused by the fabric tension and by pushing the air from under the fabric when winding up. Creases may also form on the zipper side, caused by different material thicknesses and expansion factors.

In blackout blinds, the zippers are placed on the Soltis side of the fabric, not on the side with the blackout film, in order to attain better adhesion and reduced fabric movement. It is therefore possible that due to wind or if seen at an angle, a small part of the zipper can be seen, but this is insignificant when compared with the overall view or the fabric tension (reduced creasing).

When the 86/92 fabric is used, the zippers are always on the rear side of the fabric – i.e. on the window side. In addition to placing an inscription or a logo to the fabric, it is also possible to inverse the fabric colour or the fabric side on the sun screen.

## 6. Fixtures and fittings

All fixtures and fitting are made from stainless steel, and all accessories are always part of the supply.

Fixtures and fittings for the walls and anchoring to the ground are not part of the supply.

## 7. Packing

The Veranda HRV80-ZIP-2P is supplied packed in robust cardboard boxes.

## 8. Use and maintenance

Proper use and maintenance greatly increases the lifetime of the sun screen.

- Do not use the screen as protection against rain or wind. If water-proof fabric is used, water will drain to lateral sides of the lower section. There is no water outlet (gutter) under the rails.
- Regular maintenance prevents excessive wear and operational problems.
- Cleaning the frame: use soft water instead of aggressive substances that may affect the coating and protective layers.
- Cleaning the fabric: when dry, with a semi-stiff brush.
- Clean stubborn stains using warm water and light detergent solution, rinse with copious amounts of clean water.
- Always let the fabric dry fully before rolling it up (even after an unexpected rain shower).
- It is recommended to offer a maintenance contract for the product to the end user.
- Does not provide 100% rain protection (rain water may penetrate between the wall and the box).

## 9. Safety

To ensure safety of the end user, the veranda must be installed in strict accordance with the installation instructions.

## 10. LED lighting

Optional:

- Remove the aluminium clip section from the lower front side of the box.
- Attach the LED strip to the resulting opening and overlap the opening with a small diffuser section.
- Power supply: 230 VAC / 24 VDC.
- Each part of the box is to be equipped with the LED strip and diffuser, all with own external power supply, and placed outside the box. IO or RTS or switch (switch is not part of the supply).
- The LED strip is always to be installed across the sun screen width. Less light may be experienced at the ends, depending on the LED strip length.
- The LED strip is powered by 24 VDC supply unit, 9.6 W/m.
- LED unit can only be used as supplementary lighting. The LED light colour is warm white.

### Support profile

The support profile is always installed in a fixed position, in the centre of the guide rails.

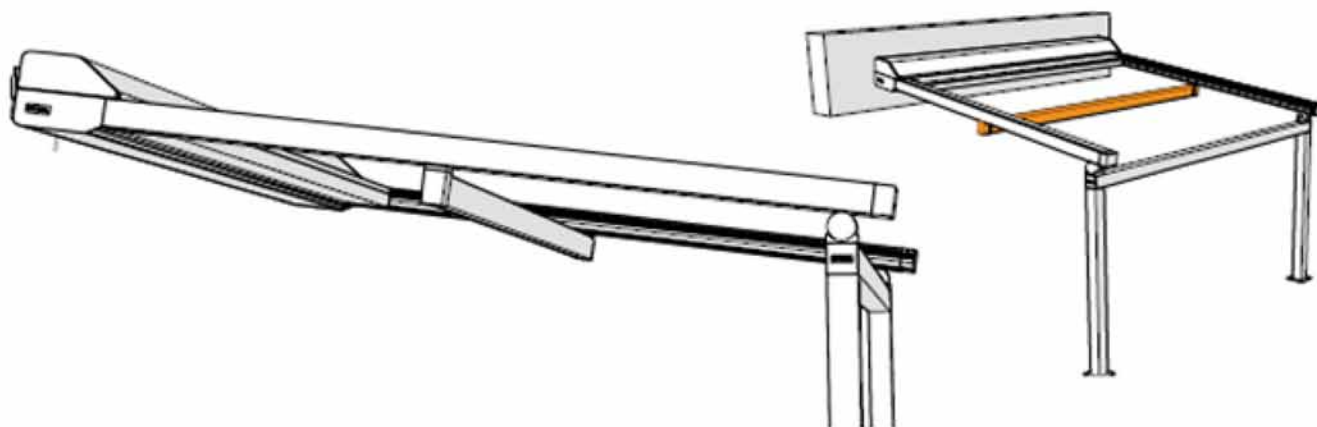

### LED lighting can be installed in the support profile

- The profile can be adjusted in the range of 20° in both directions
- One support profile is supplied as standard

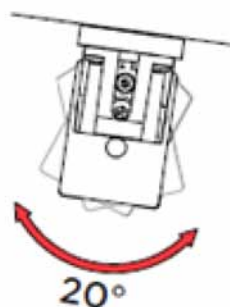

### ATTENTION

**VERANDA HRV80-ZIP-2P – the support profile is supplied automatically for extensions over 4 m.**

**VERANDA HRV80-ZIP-2P pp – the support profile is always supplied.**

**Control:**

1. Dimmable IO control:

LED lighting can be controlled by all IO controllers

2. RTS control:

The lighting can be controlled by all RTS controllers

3. With no control:

The included power cable can be connected to a switch (switch is not included)

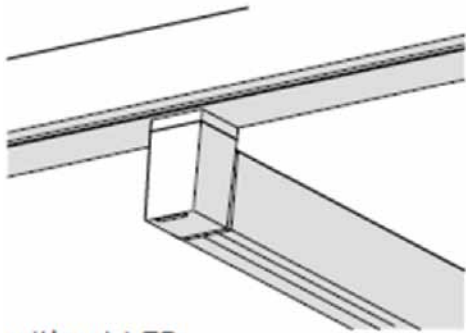

without LED

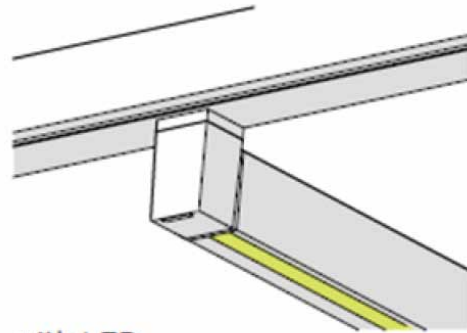

with LED

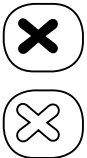
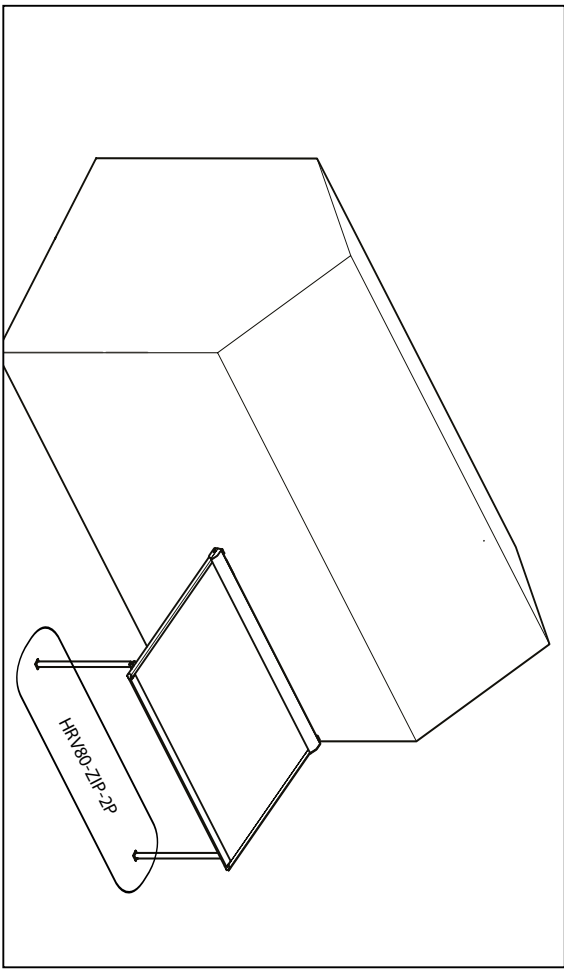
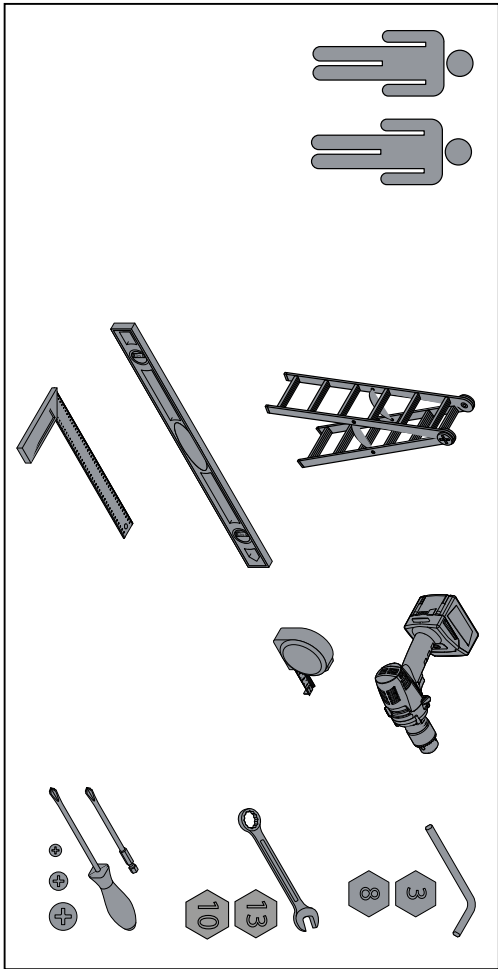

ASSEMBLY STEPS



INTERMEDIATE STEPS



VERANDA HRV80-ZIP-2P

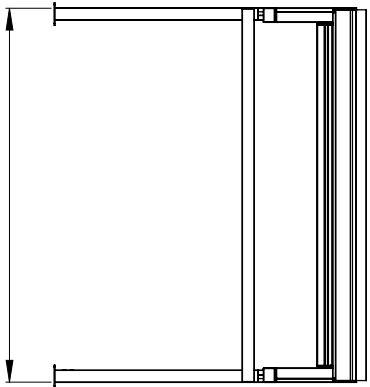
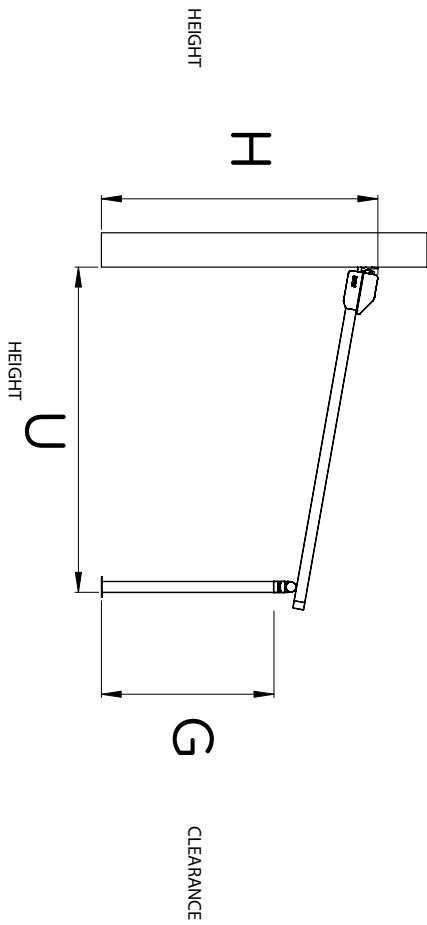

WIDTH

1



max. 4m

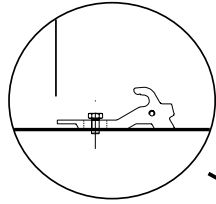
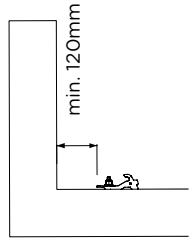
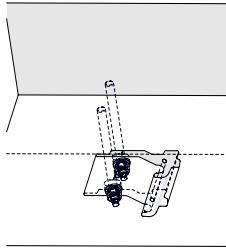
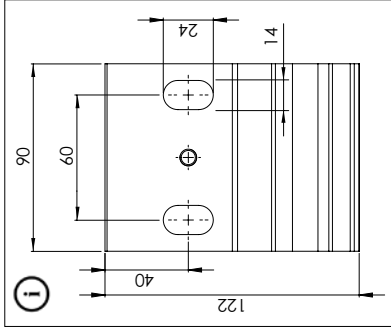

$*(H - 10\text{ mm}) =$

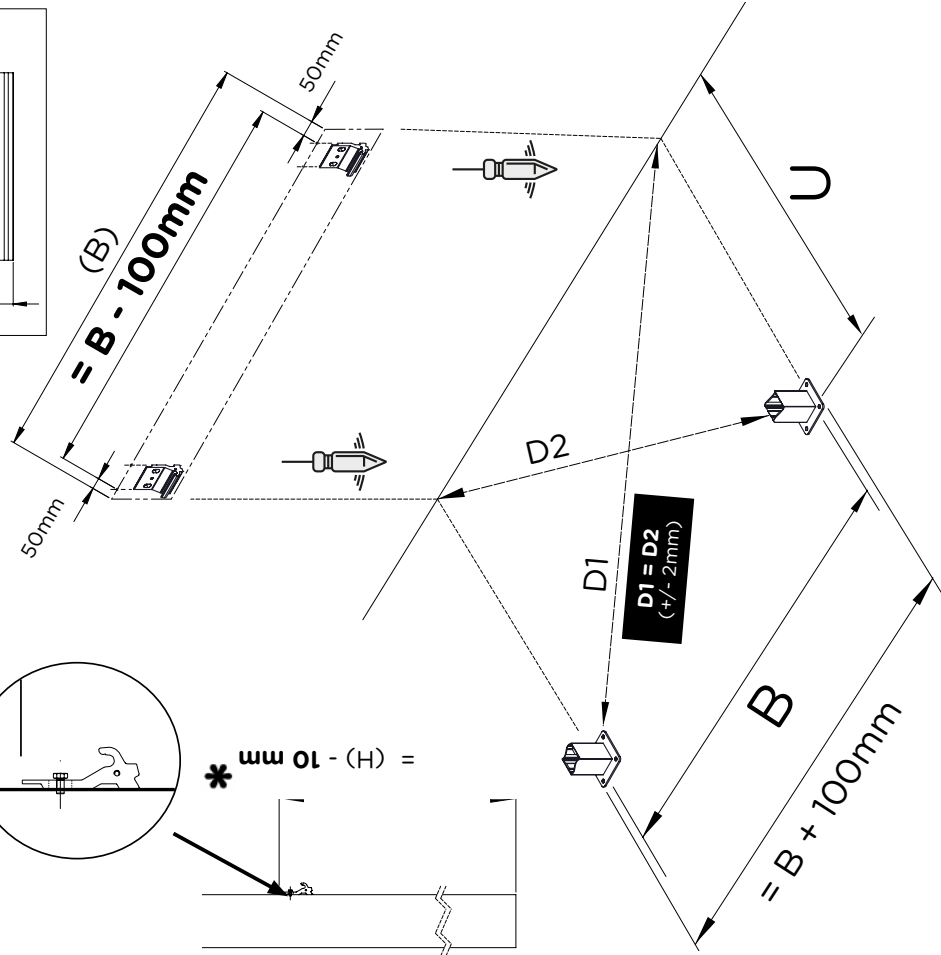

COUPLED

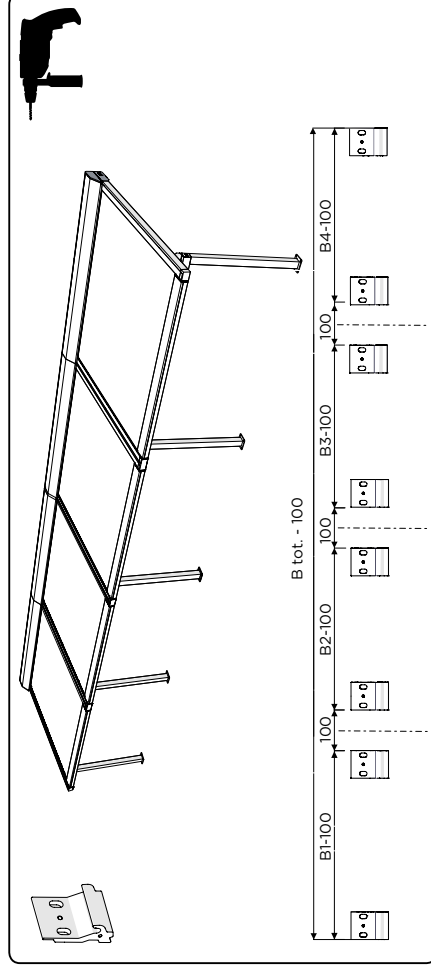
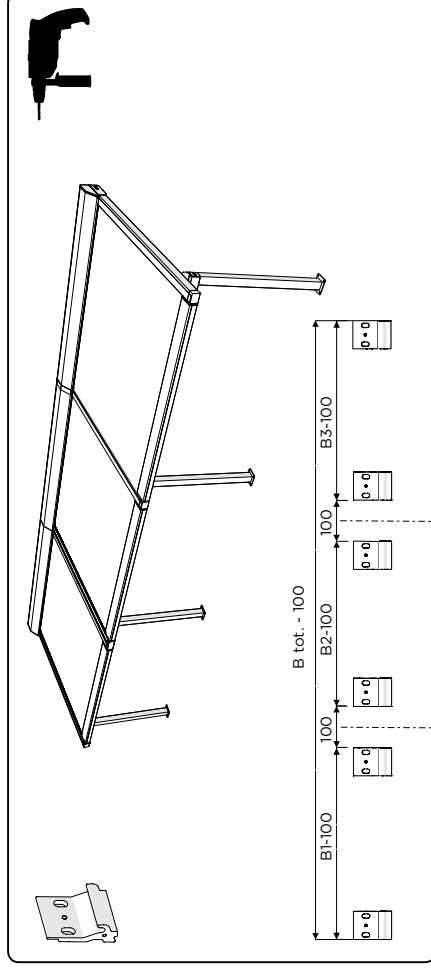
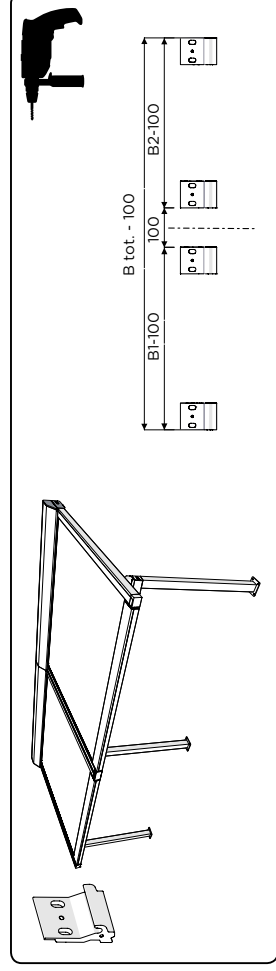

2

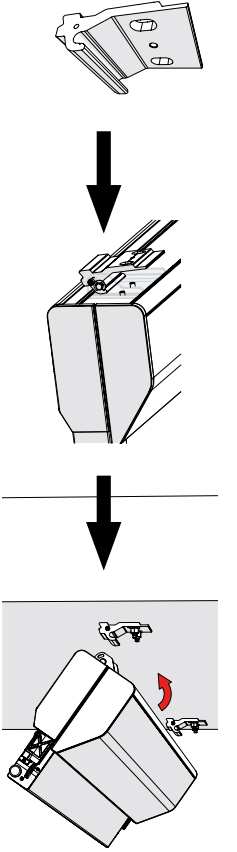

3

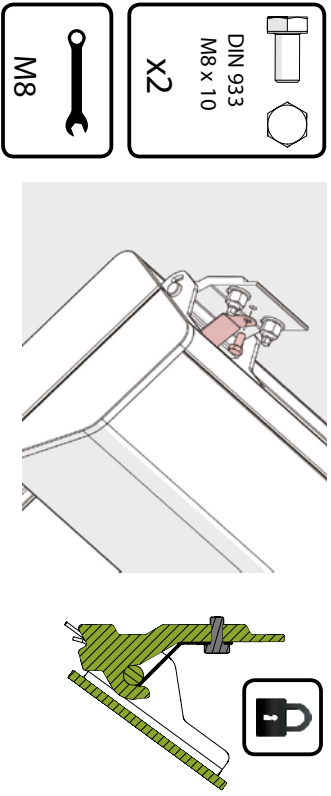

4

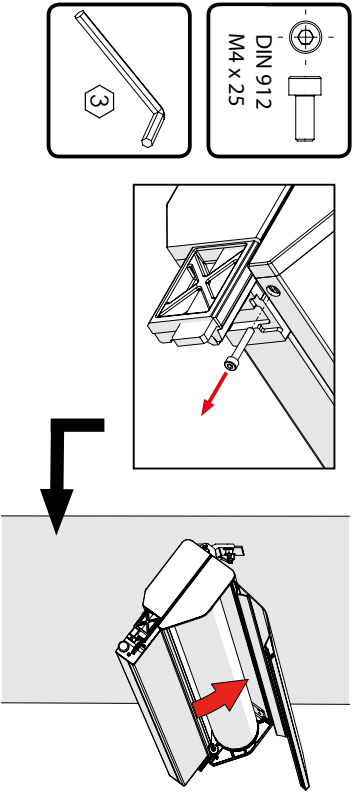

5

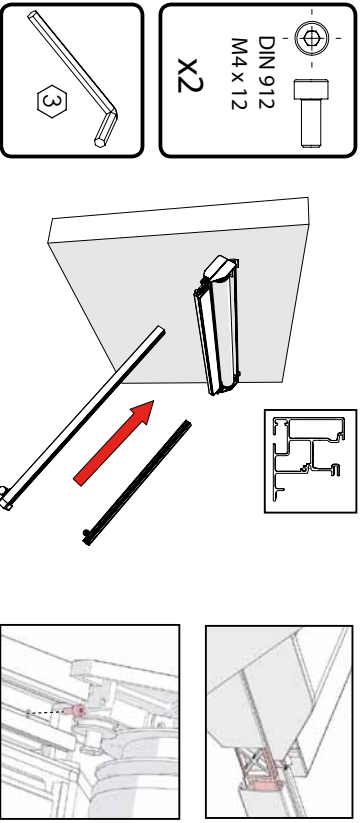

6

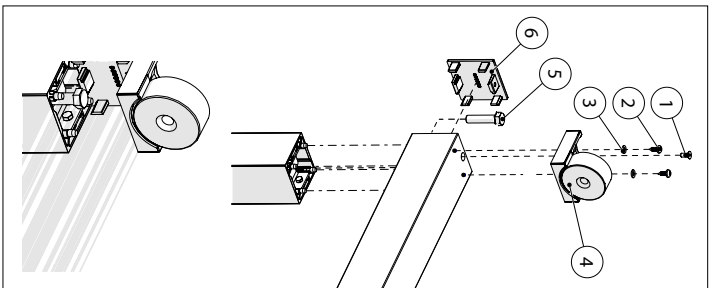
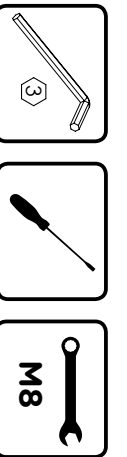

1	Din 7991 M4 x 12	2
2	Din 7981 4,8 x 13 mm	4
3	Din 125 - M5	4
4	050905	2
5	DIN 933 - M10 x 35	2
6	050699	2
7	DIN 7982 4,8 x 19	8
8	050940	2

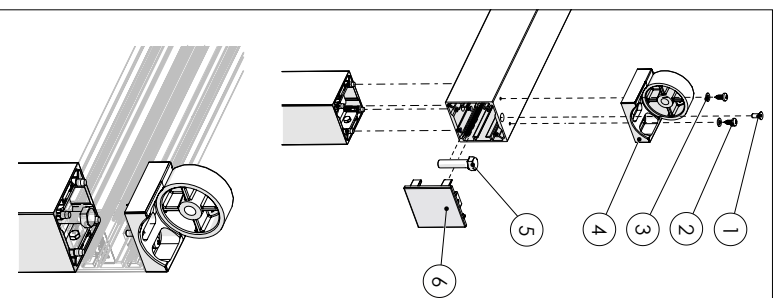
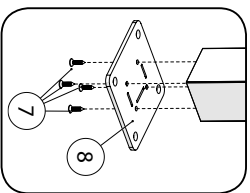
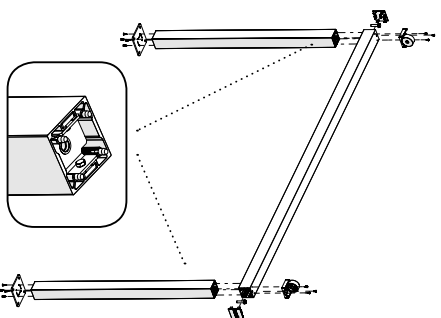

7

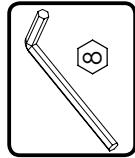
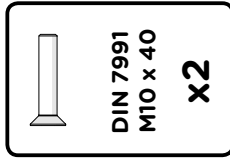
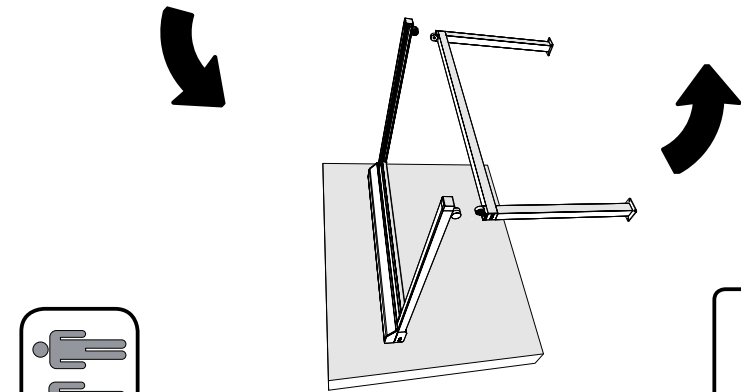
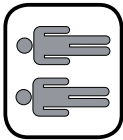

8

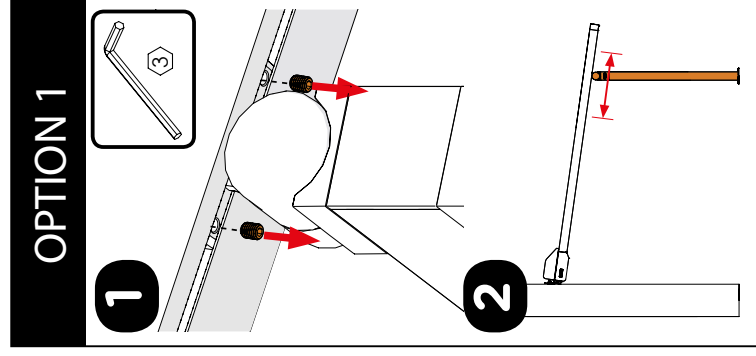
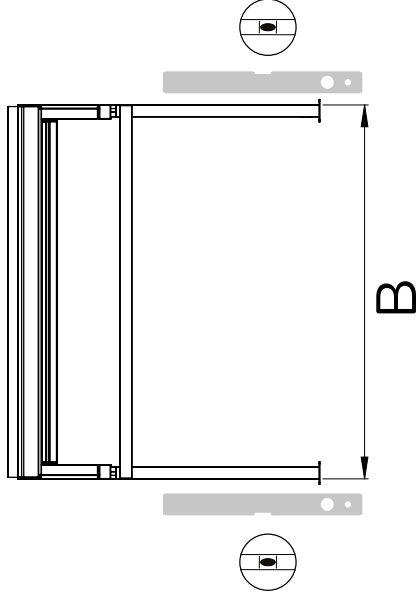
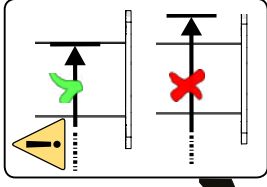
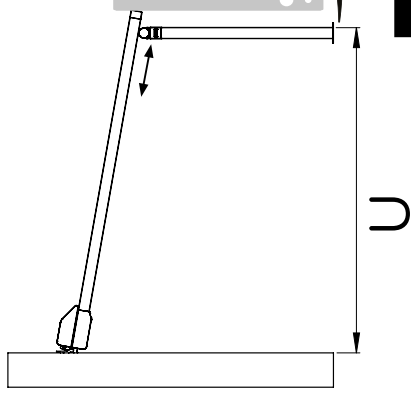
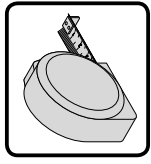

DO NOT ANCHOR THE STANDS TO THE GROUND YET!

9

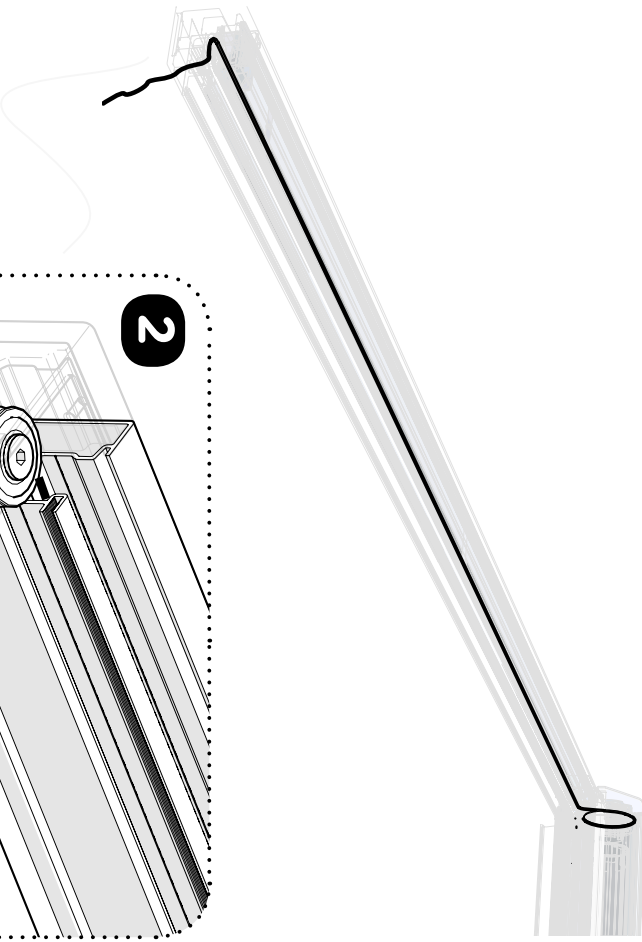
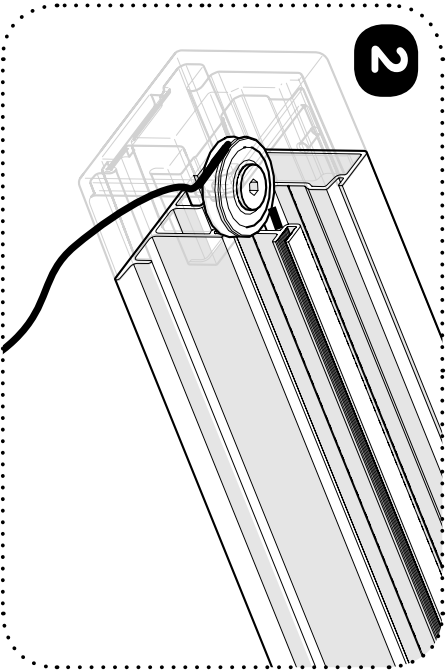
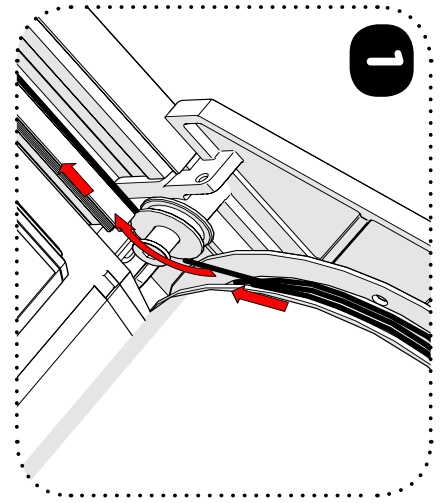
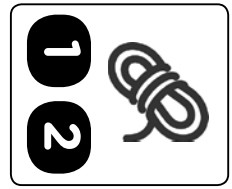

10

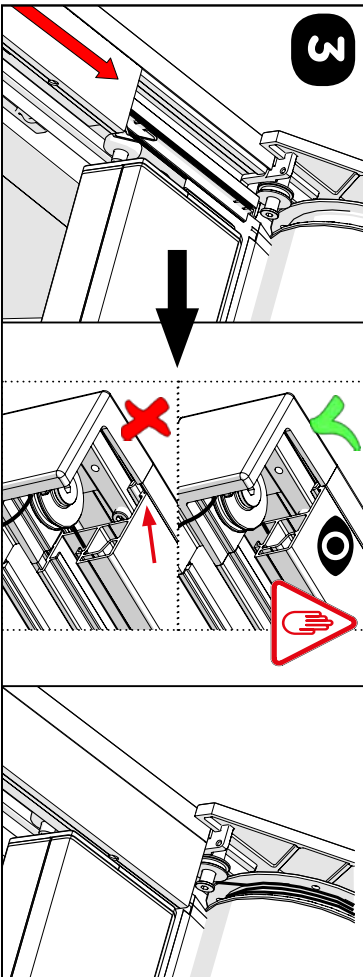
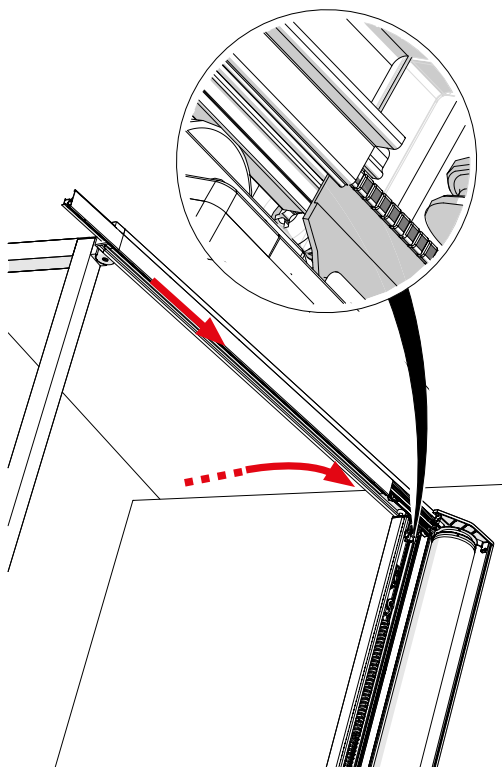
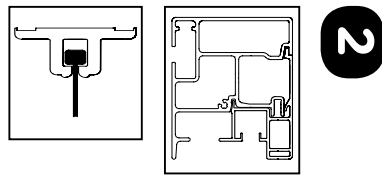
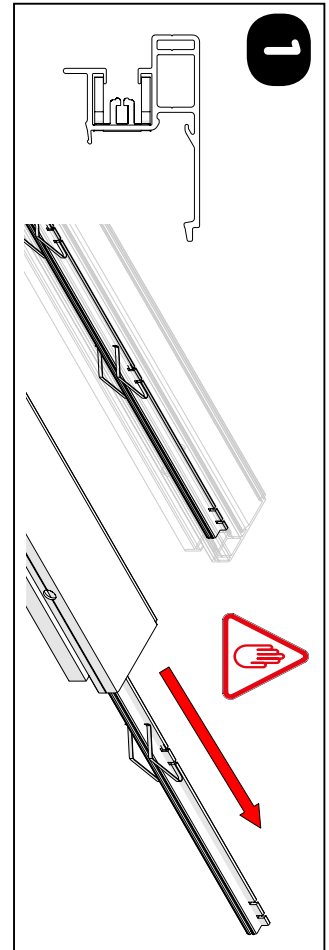

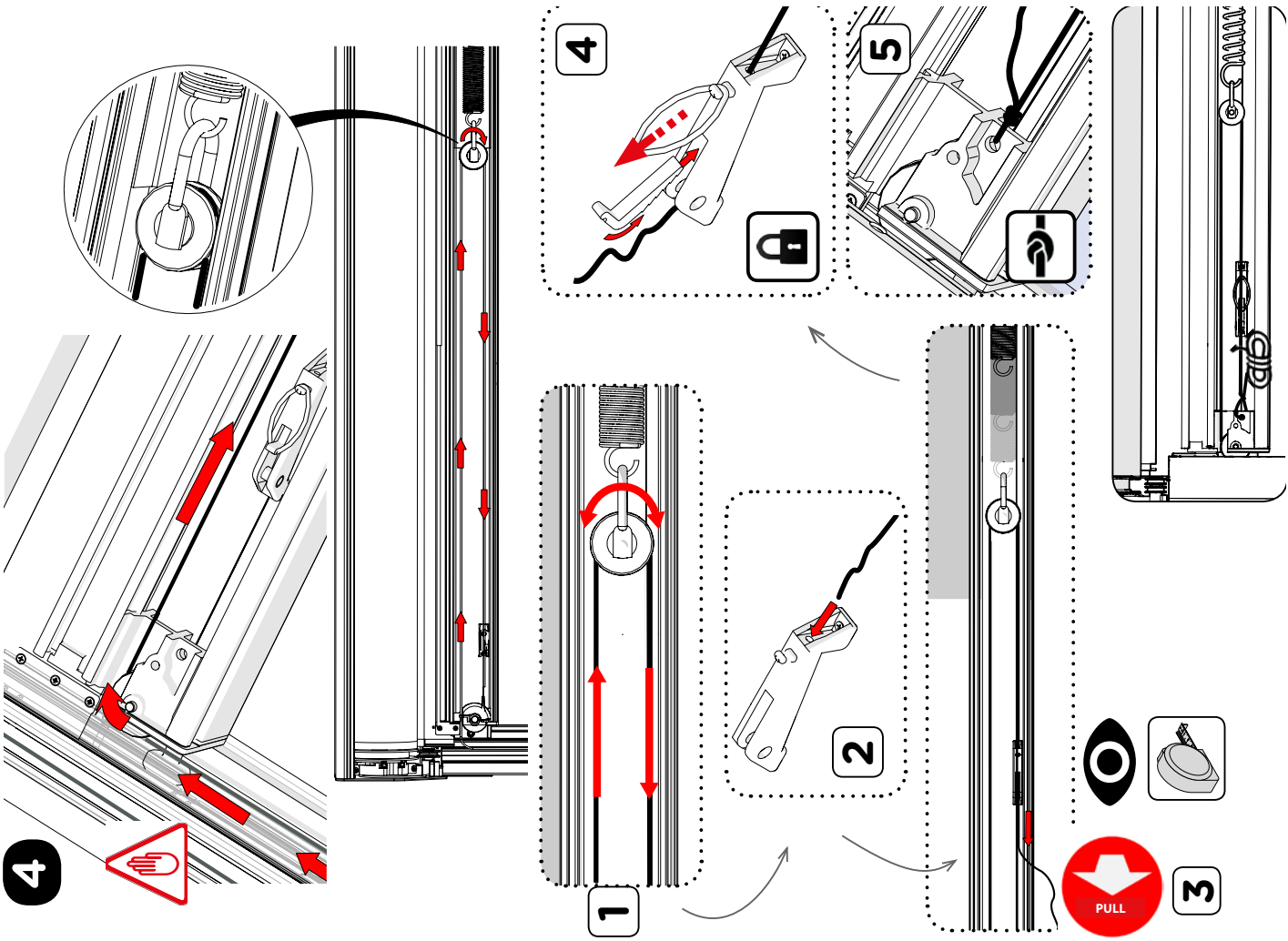

Do not shorten the cable.

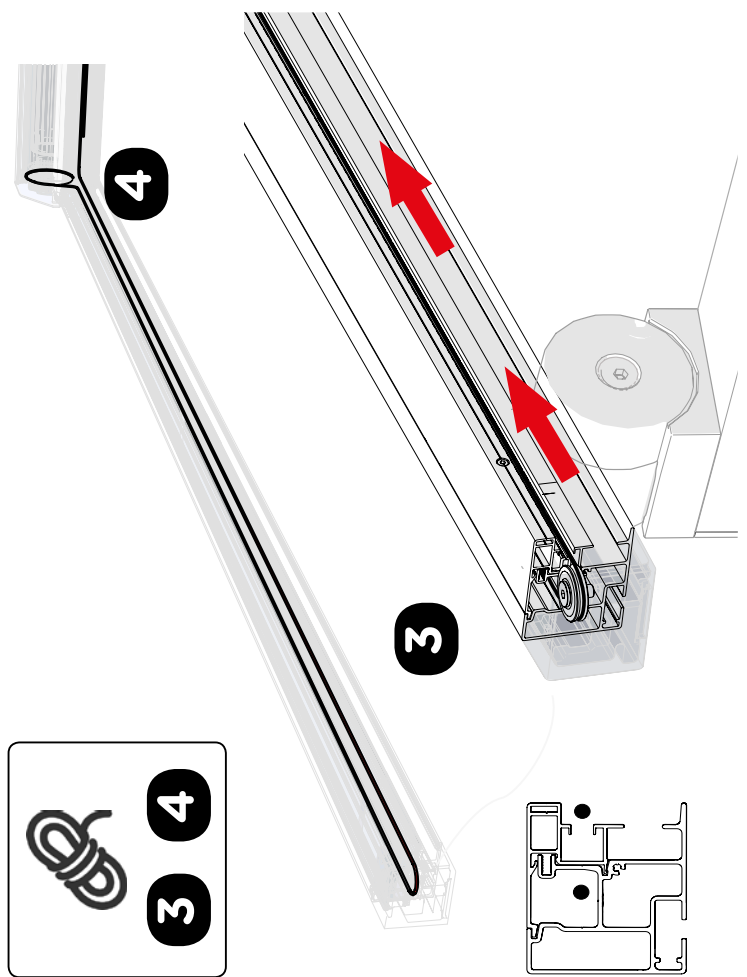
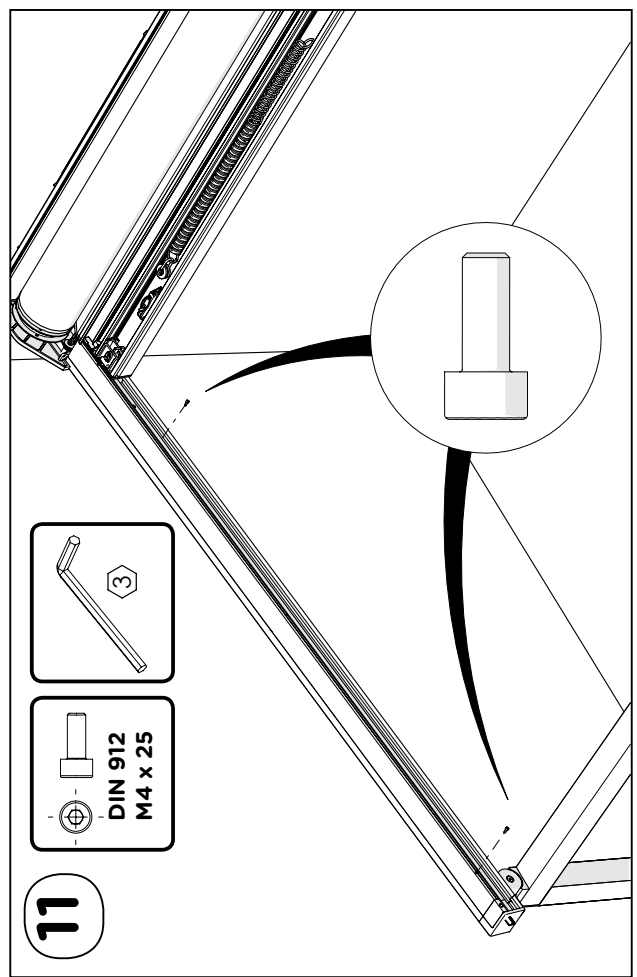

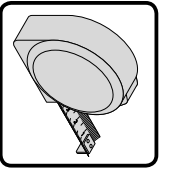
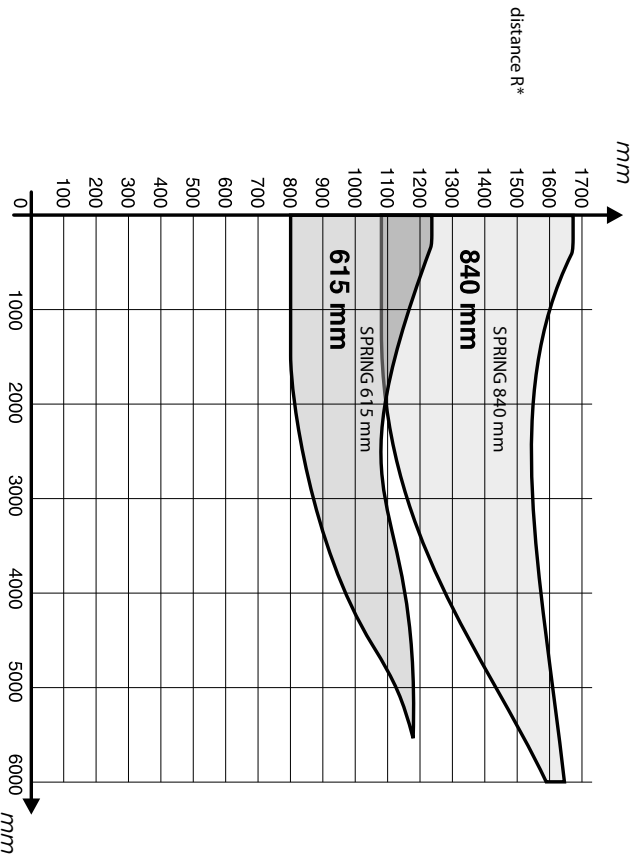
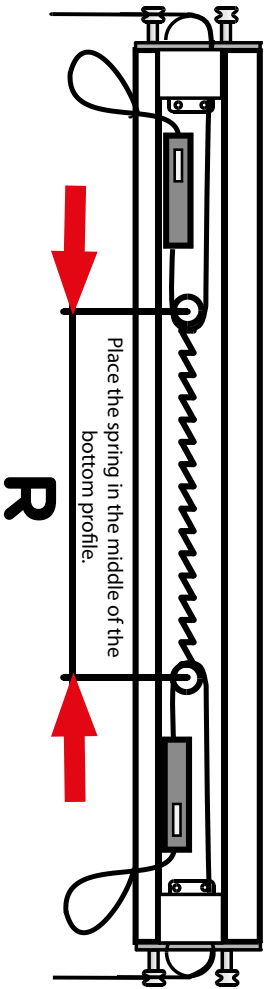
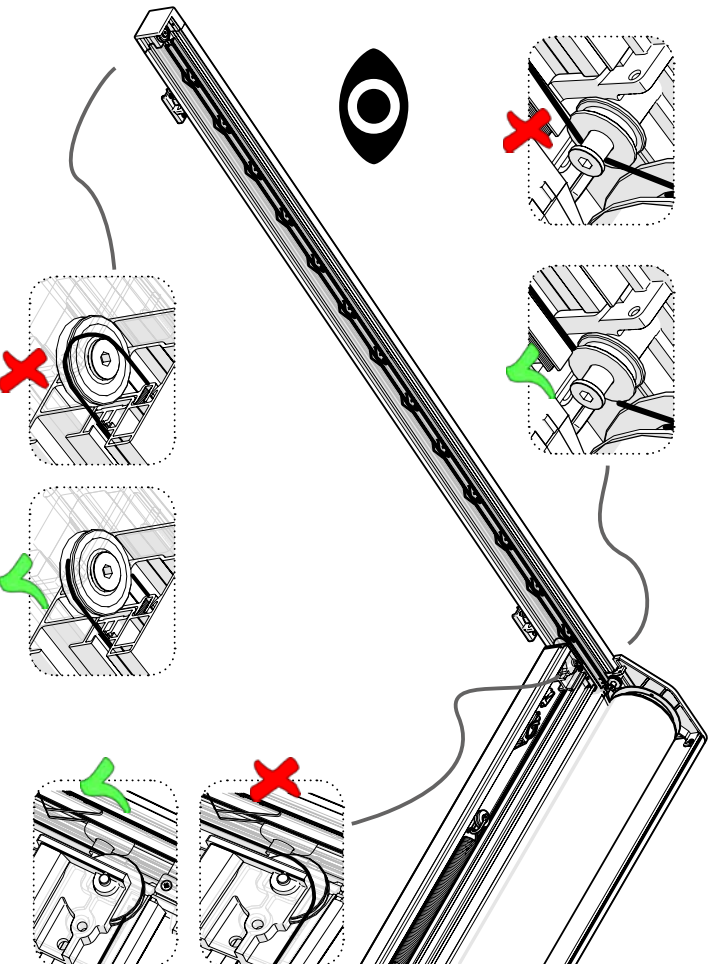
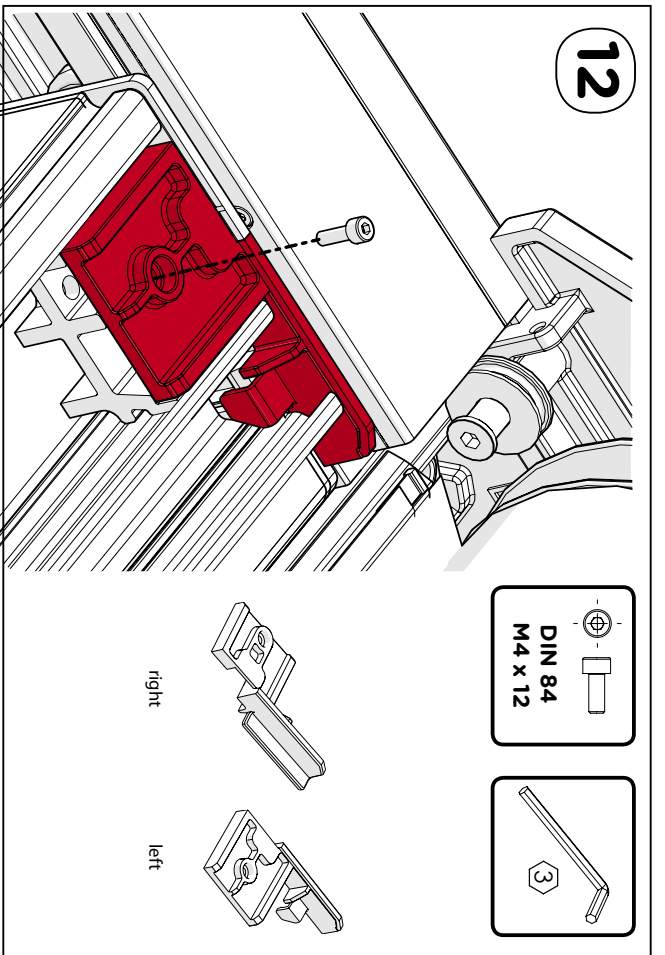

TABLE – spring distance R (in mm)



\* READ THE DISTANCE R IN THE COLOUR ZONE DEPENDING ON THE TYPE OF SPRING (650 mm / 850 mm).

Stretch the spring up in the range according to the table (if the spring is overstretched, the fabric may be pulled out of the zipper of the guide rail).



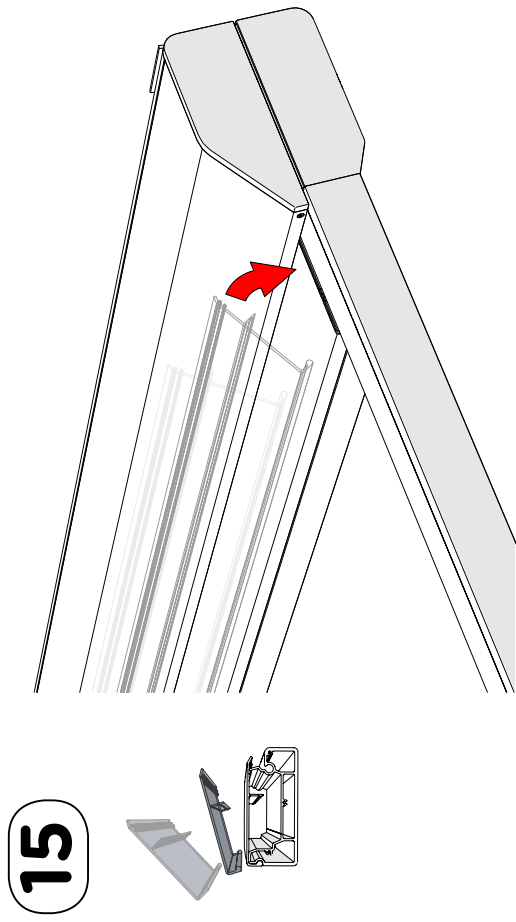
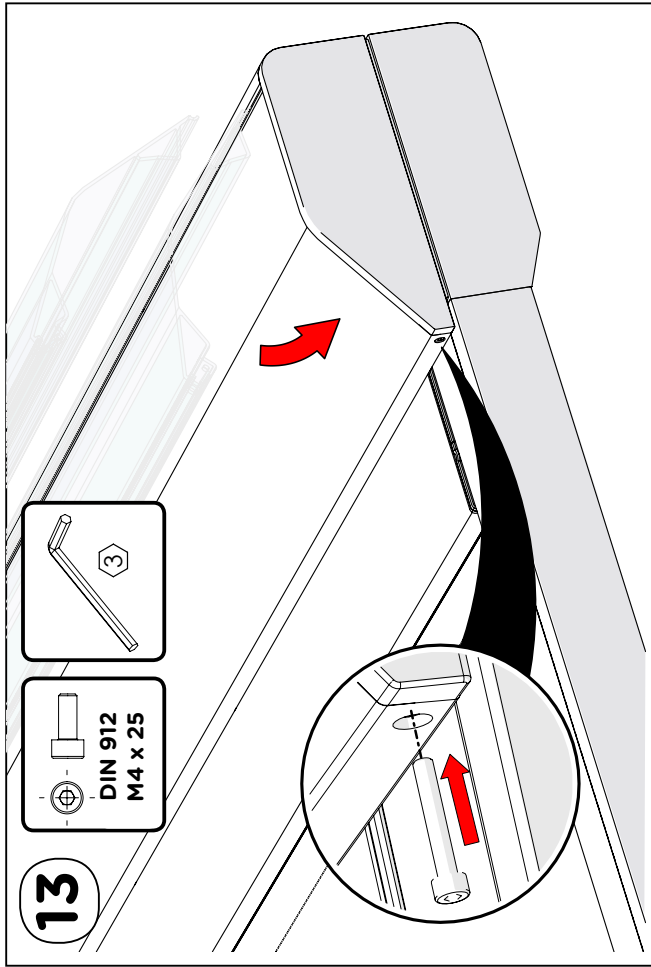

**somfy**  
www.somfy.com

OREA 50 WT 25/17  
OREA 50 WT 40/17  
Orea 25/17 LT50 RTS  
Orea 40/17 LT50 RTS  
Sunea 50 IO 25/17  
Sunea 50 IO 40/17

see Somfy instruction manual (included)

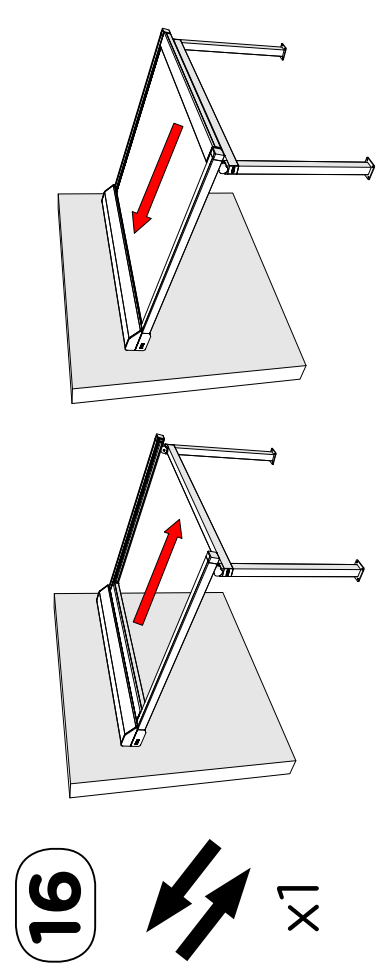
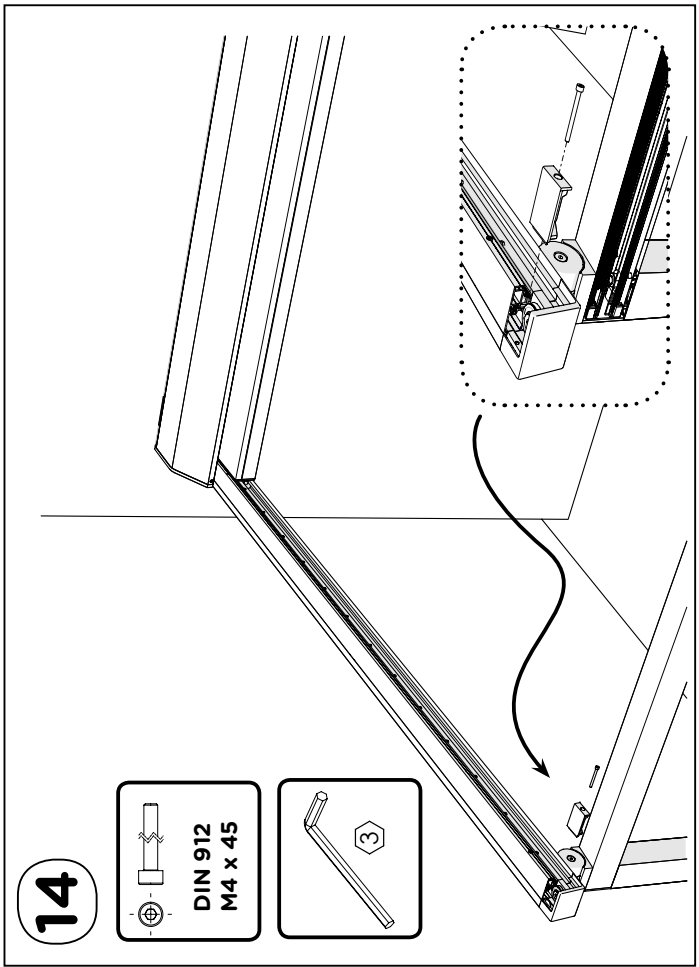

17

CHECKING

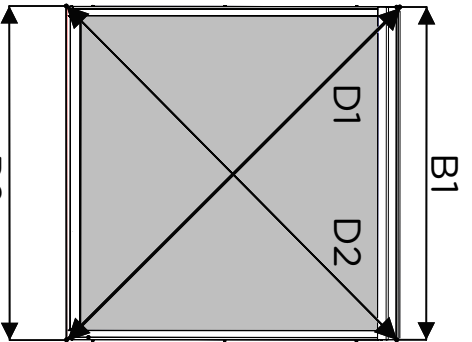
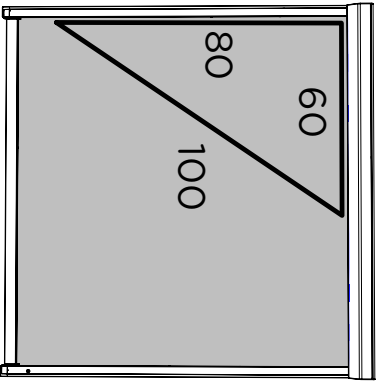

**B1 = B2 & D1 = D2**  
 (+/- 2mm) (+/- 2mm)

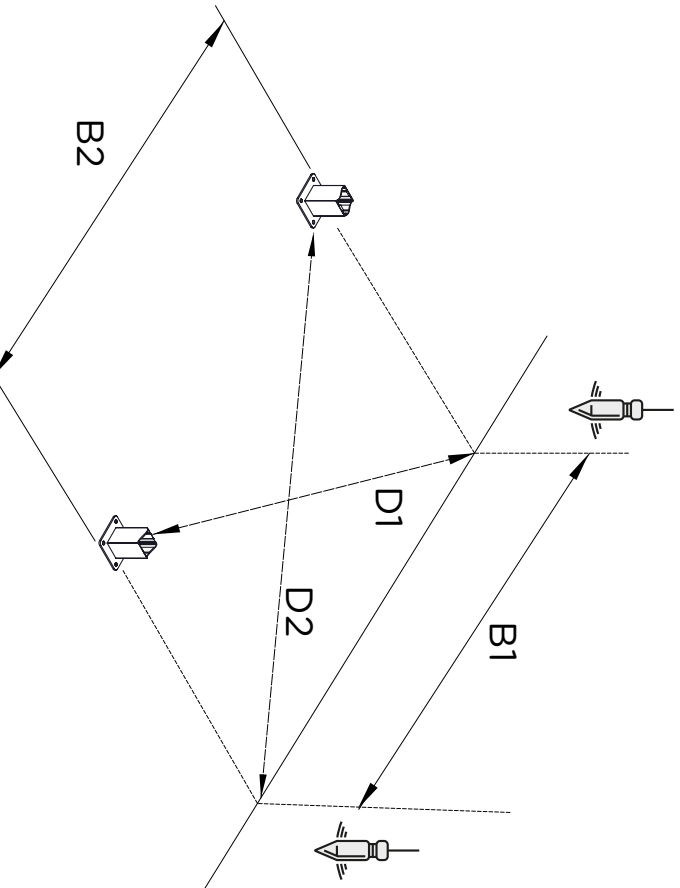

18

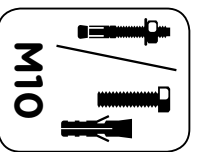

USE FIXTURES AND FITTINGS THAT CORRESPOND TO THE CONDITIONS IN THE PLACE OF INSTALLATION!

EXAMPLE

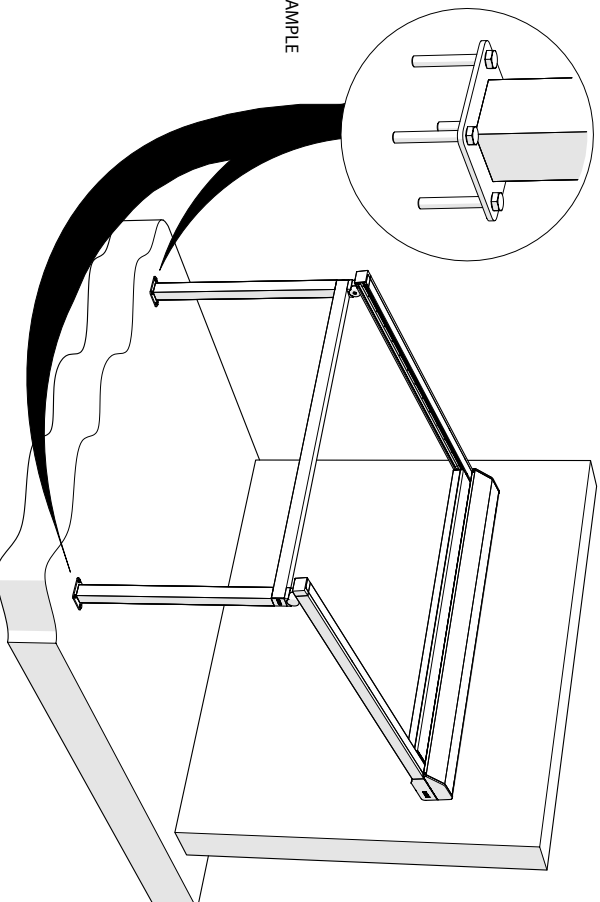

EXAMPLE

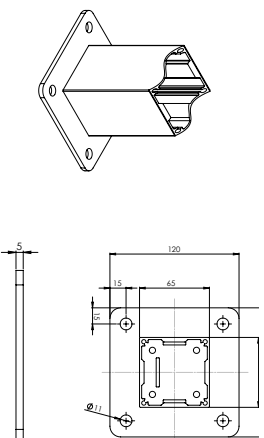
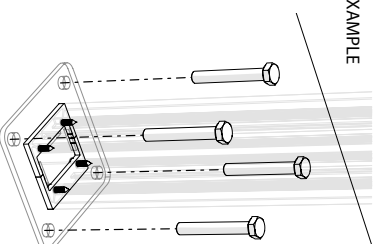

**COUPLED**

1

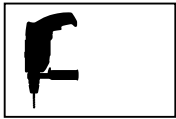

2

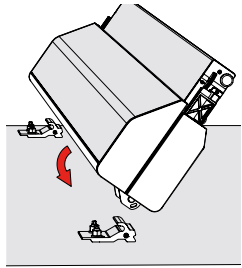
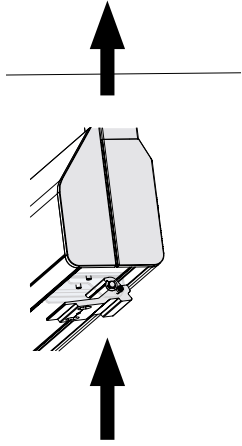
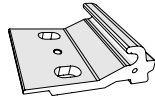

3

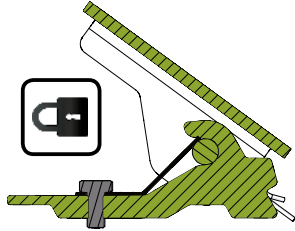
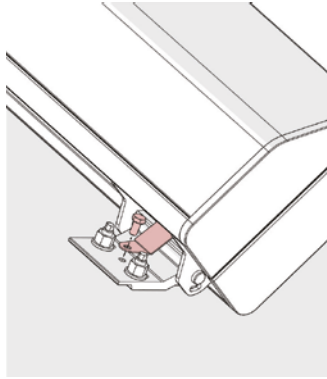
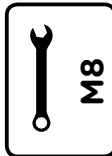
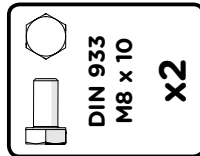

TYPE 2  
TYPE 3  
TYPE 4

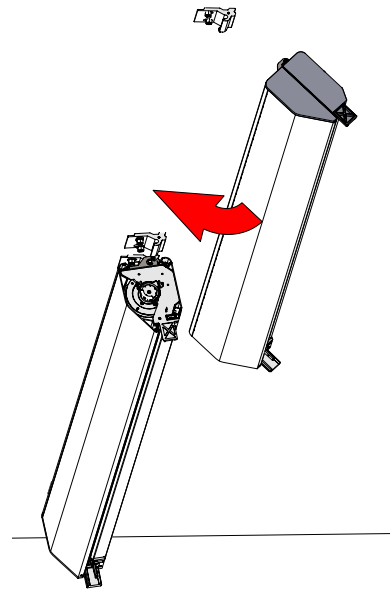

4

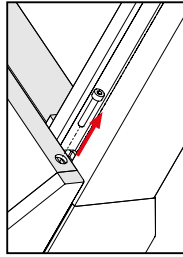
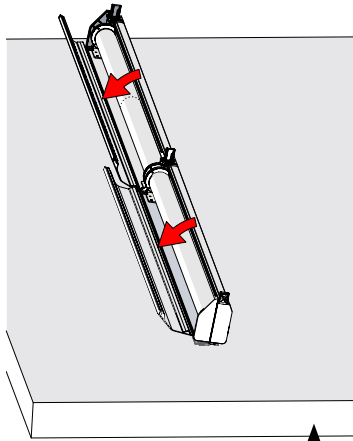
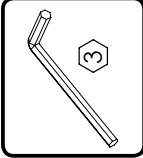
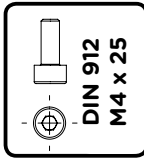

5

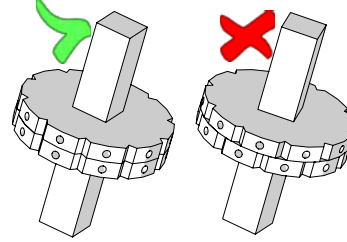
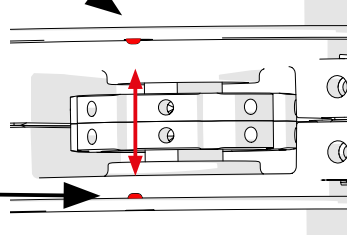
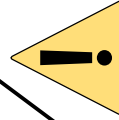
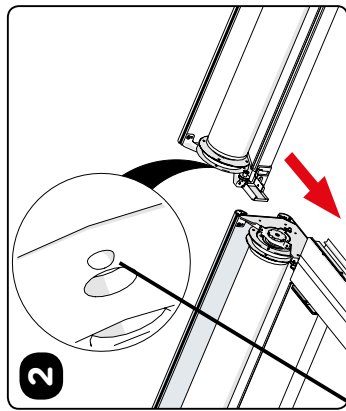
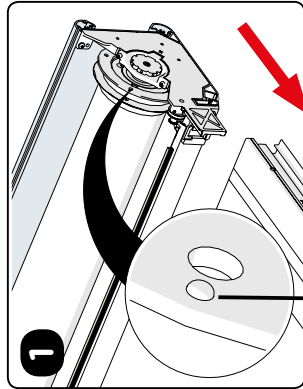

6

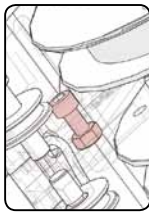
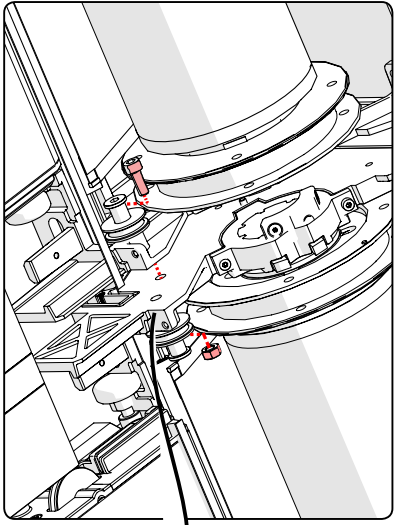
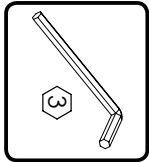

8

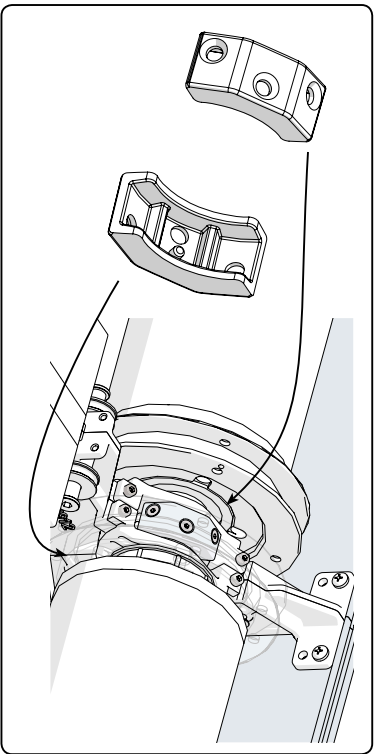
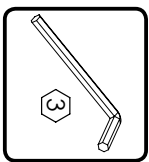
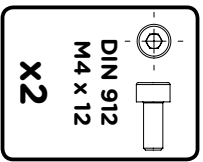

7

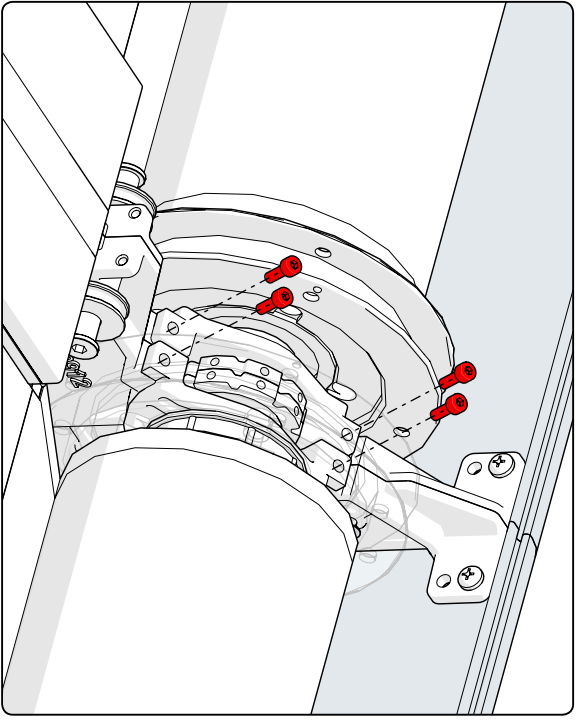
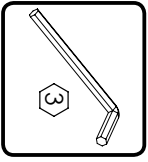
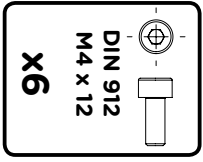

9

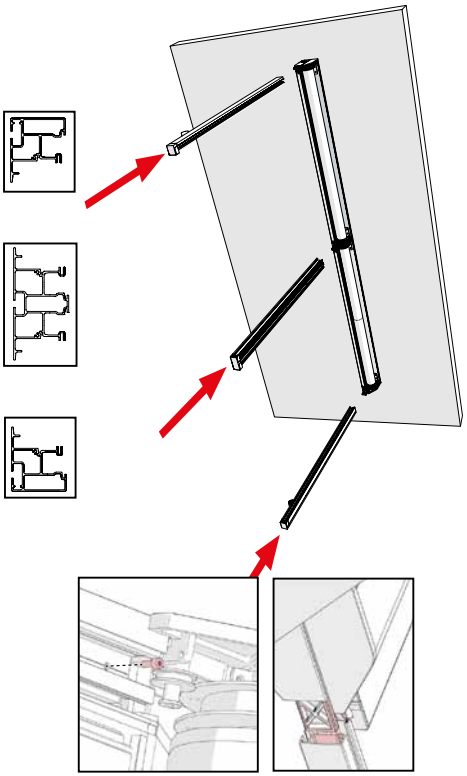
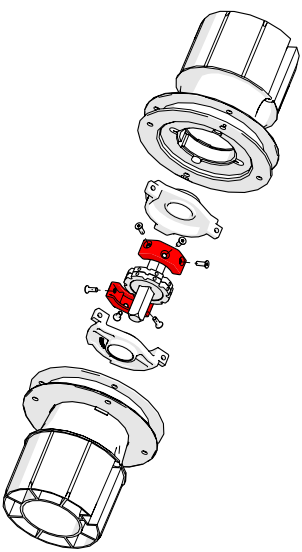
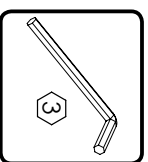
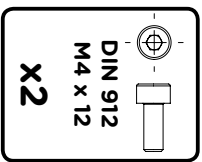

10

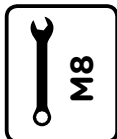
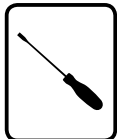
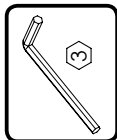

TYPE 2

1	Din 7991 M4 x 12		2
2	Din 7981 4,8 x 13 mm		6
3	Din 125 - M5		4
4	050905		3
5	DIN 933 - M10 x 35		4
6	050699		2
7	DIN 7982 4,8 x 19		8
8	050940		2

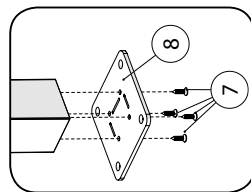
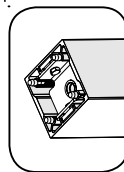
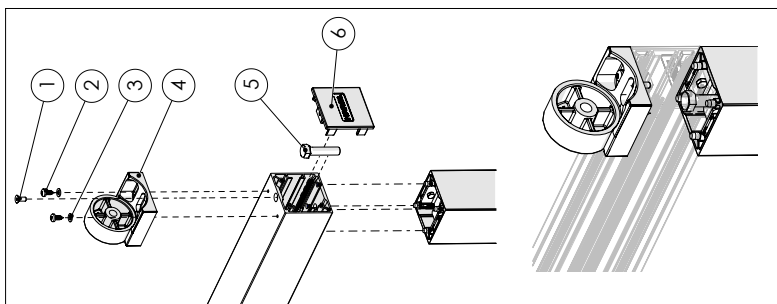
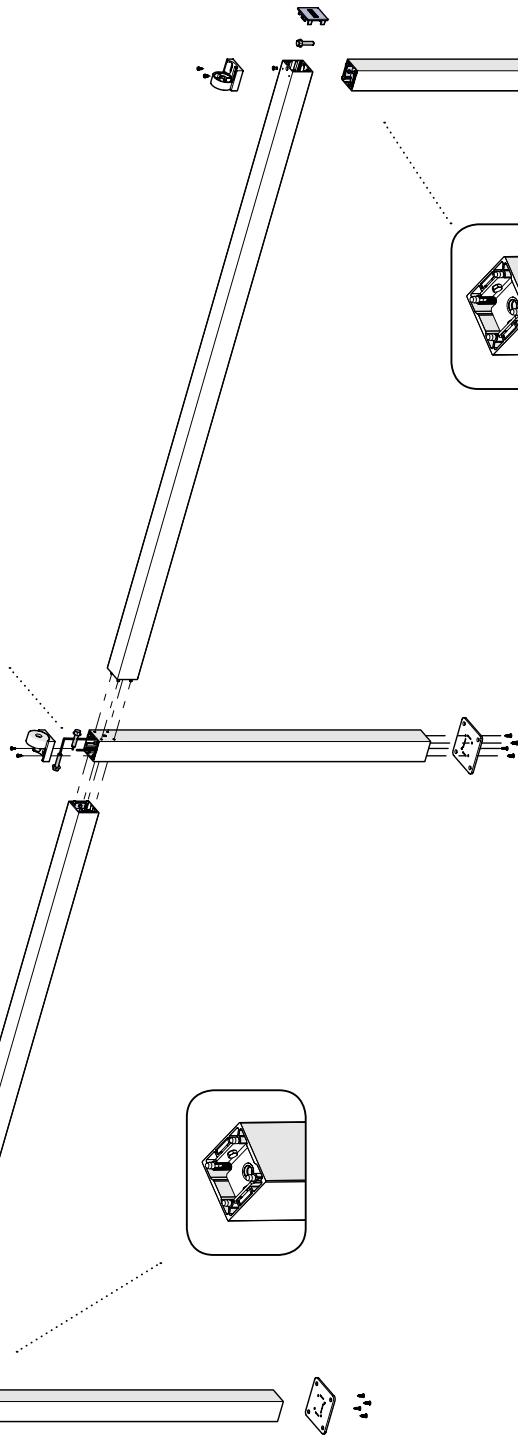
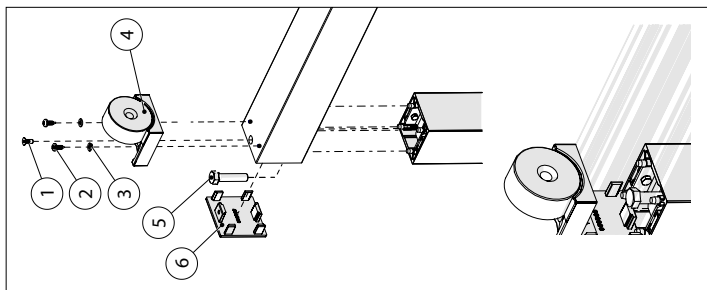
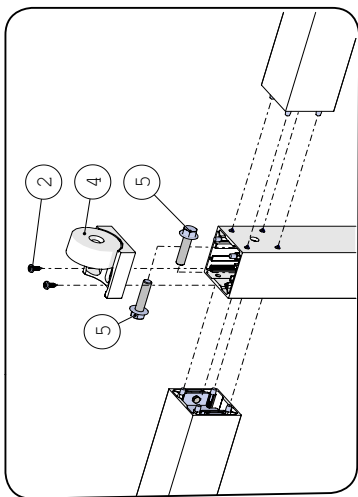

6

7

...



18

TYPE 3-4

1 → 10

6

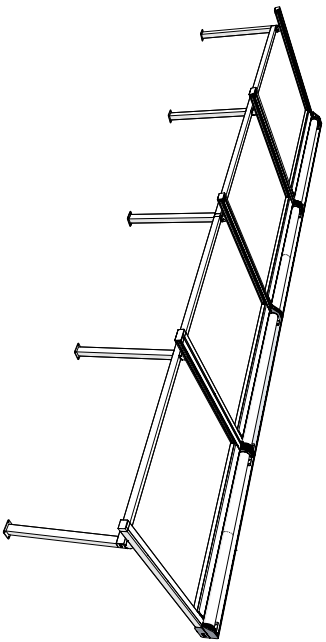
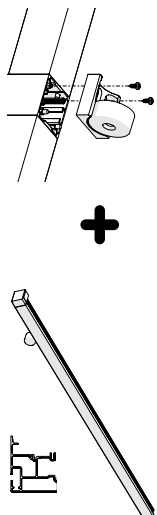
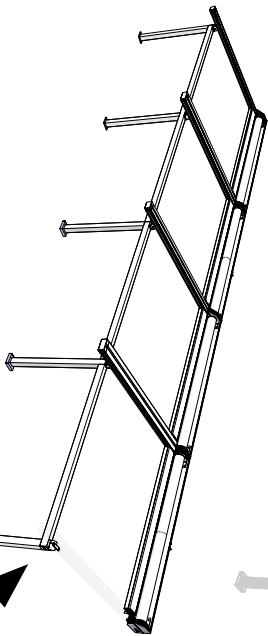
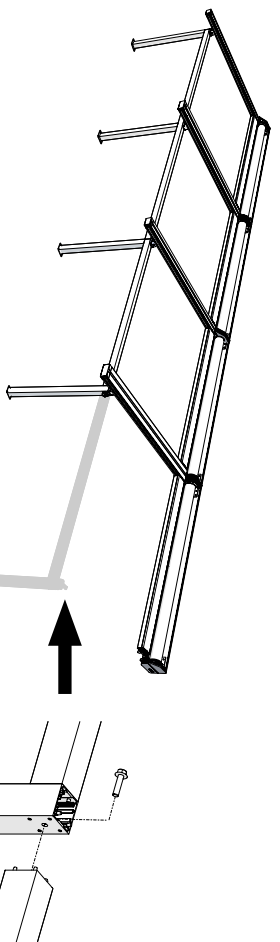
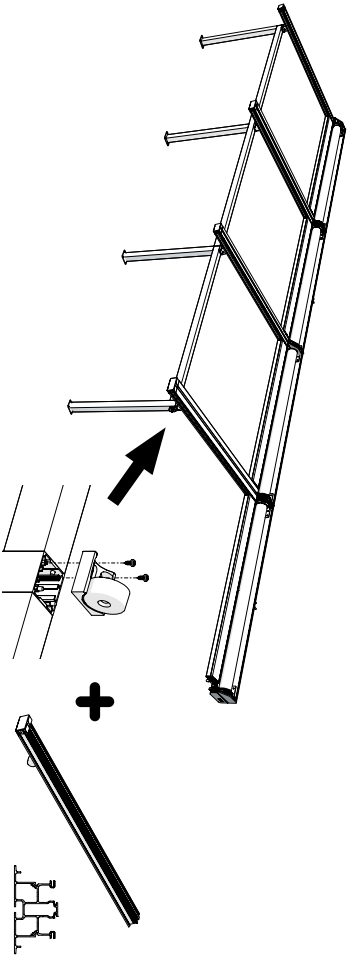
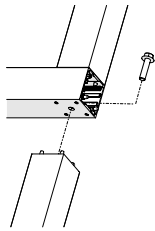
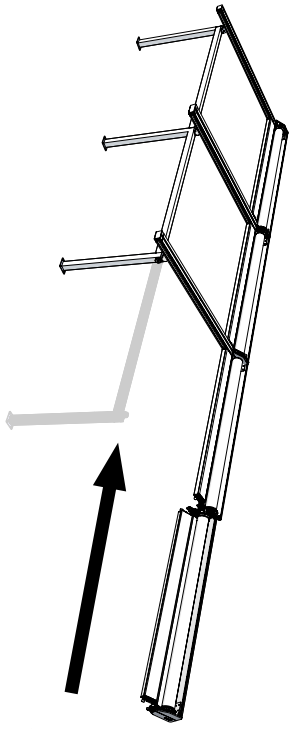
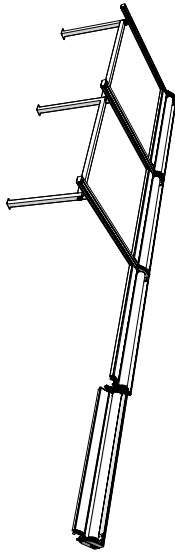
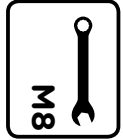
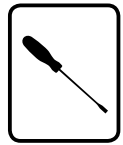
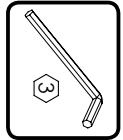

6 7 ... → 18

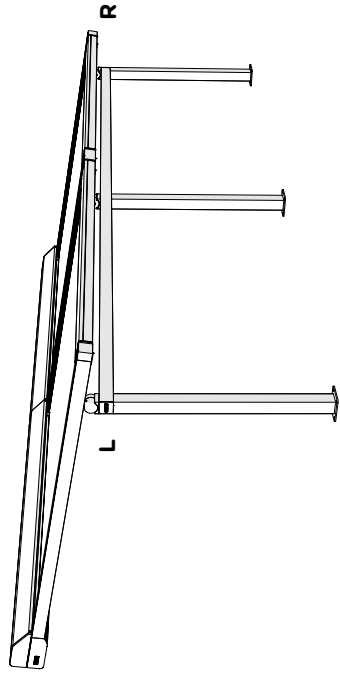

<b>left</b>		 050906 050905
-------------	--	----------------------

<b>central</b>		 050907 050905
----------------	--	----------------------

<b>right</b>		 050905 050906
--------------	--	----------------------

# VERANDA HRV80-ZIP / VERANDA HRV80-ZIP 2P FABRIC REPLACEMENT

## A) REPLACING THE FABRIC IF THE MOTOR IS WORKING

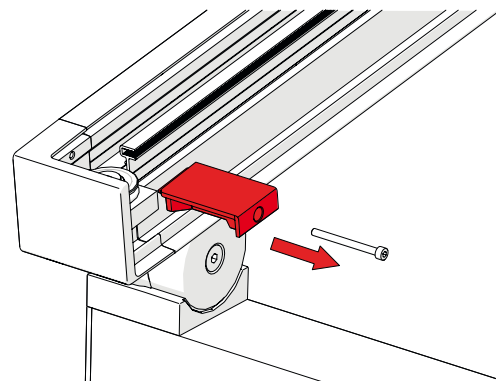
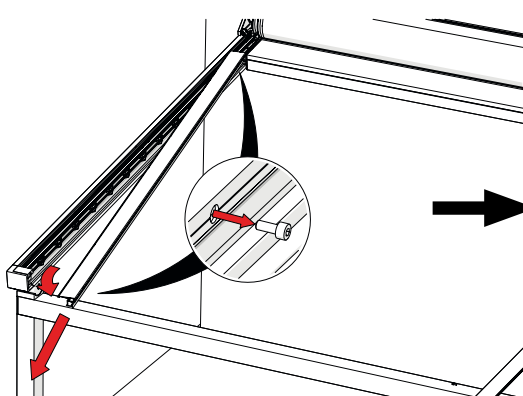
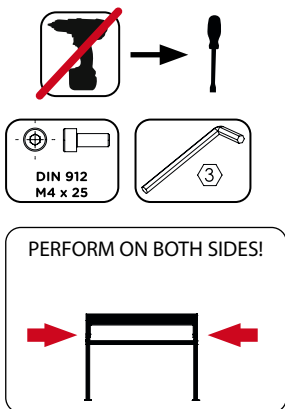
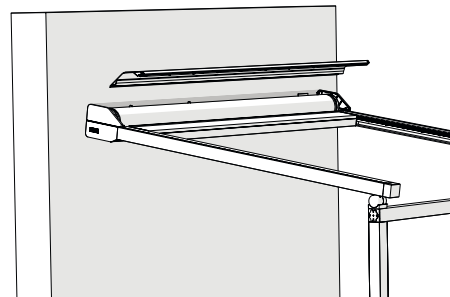
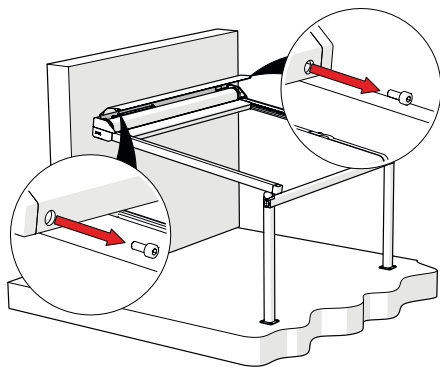
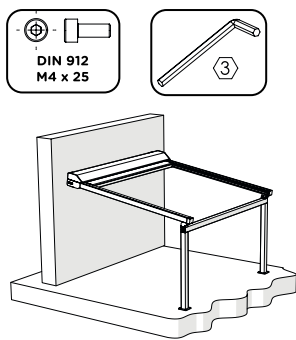

REMOVE THE CORD



CAUTION! THE CORD IS TAUT

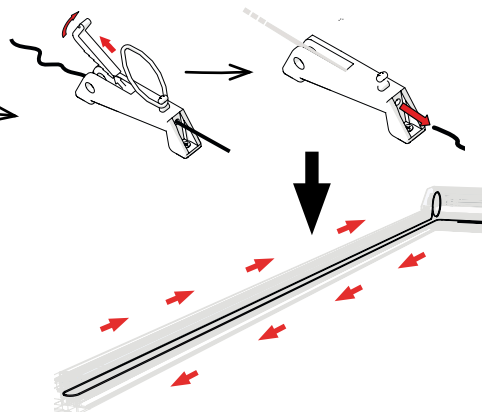
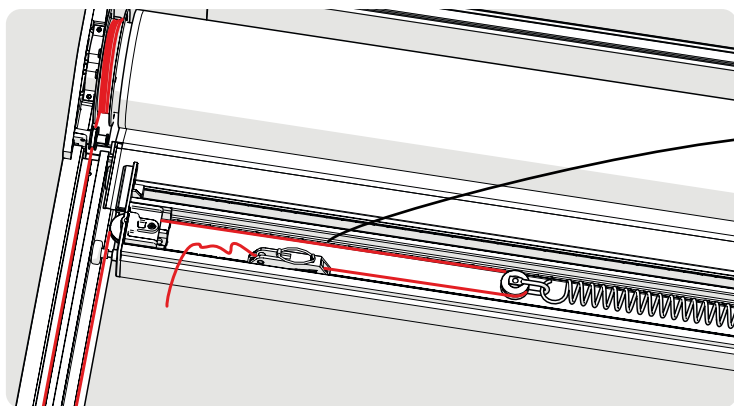
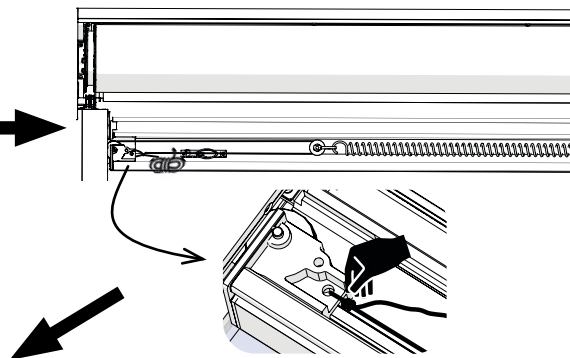
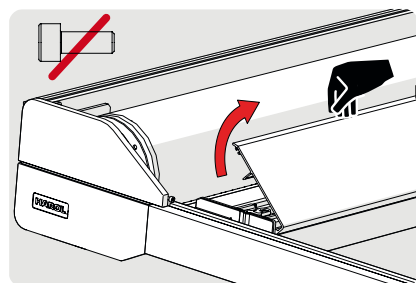
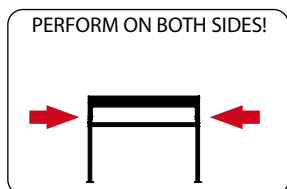

# REPLACING THE FABRIC ON THE DRUM

REMOVE THE FABRIC

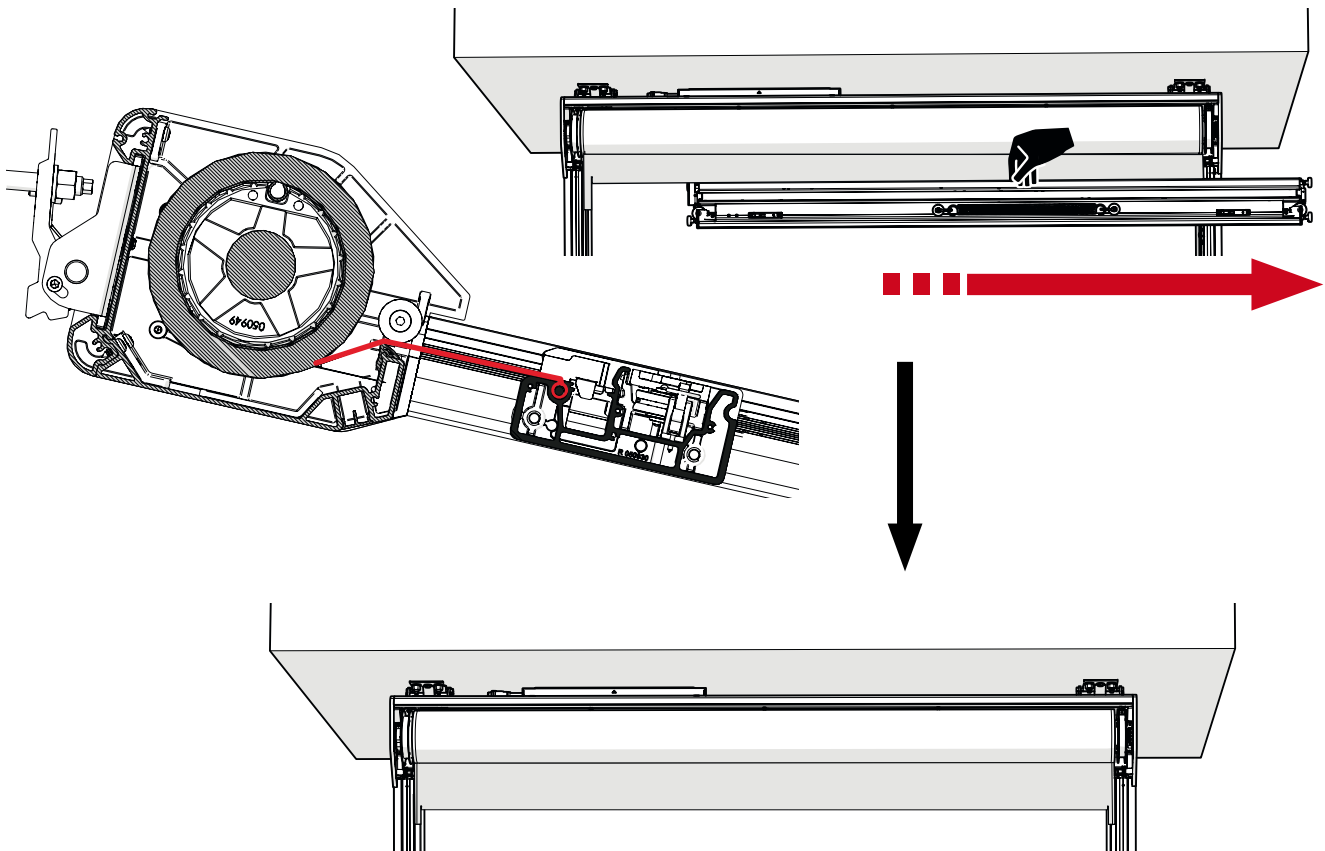
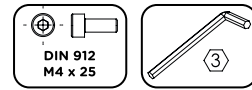
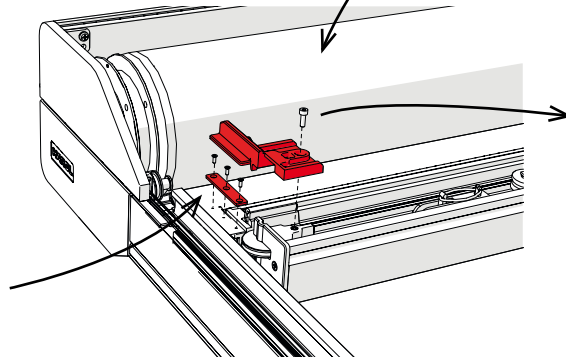
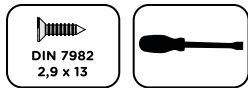
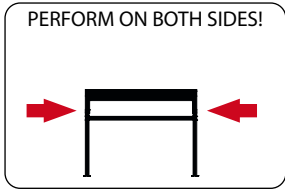
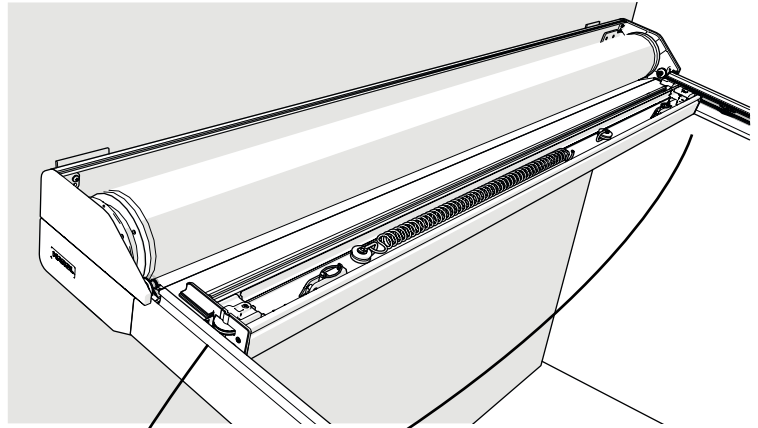

ADJUST THE END POINT SO THAT IT IS POSSIBLE TO FULLY UNROLL THE FABRIC!

**somfy.**  
www.somfy.com

see the Somfy instruction manual

OREA 50 WT  
OREA LT50 RTS  
SUNEA 50 IO

CLIP ON / CLIP OFF profile

Final assembly step showing the side profile being clipped onto the fabric.

REMOVE THE FABRIC

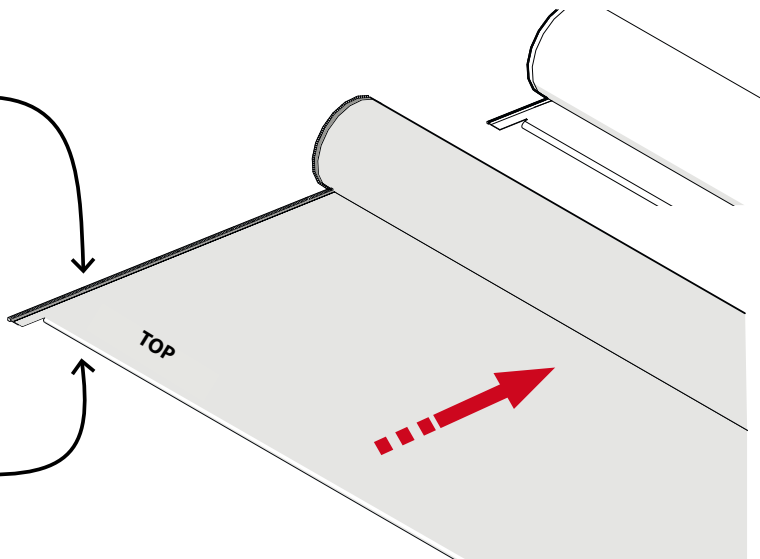
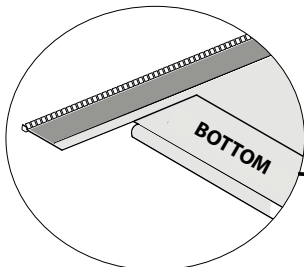
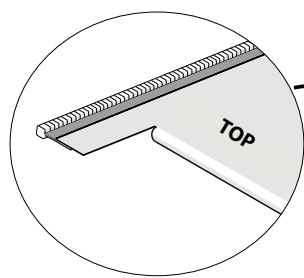

READJUST THE END POINT SO THAT IT IS POSSIBLE TO FULLY UNROLL THE FABRIC!

**somfy.**  
www.somfy.com



see the Somfy instruction manual



OREA 50 WT  
OREA LT50 RTS  
SUNEA 50 IO

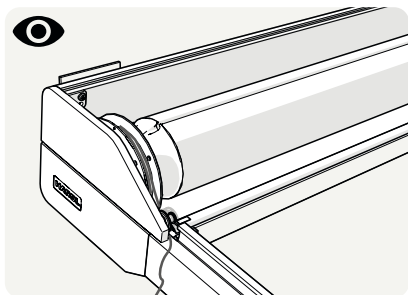

FABRIC POSITION

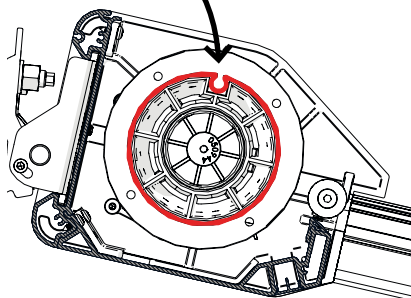

DRUM POSITION

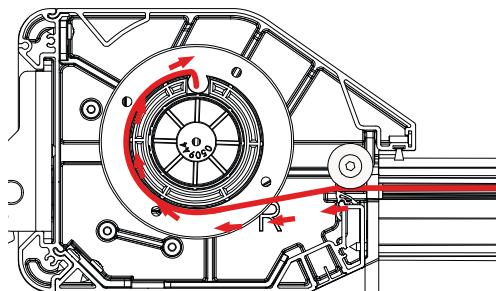
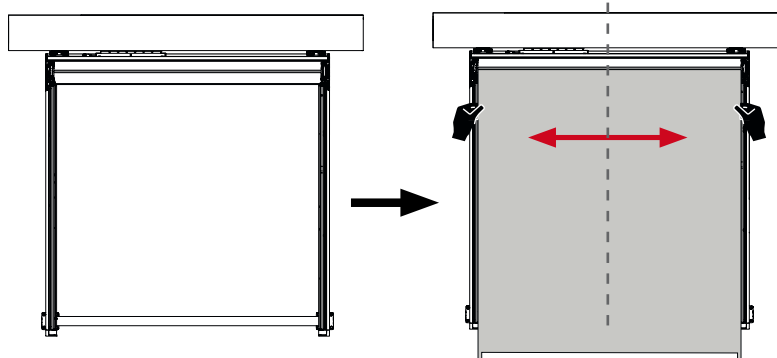

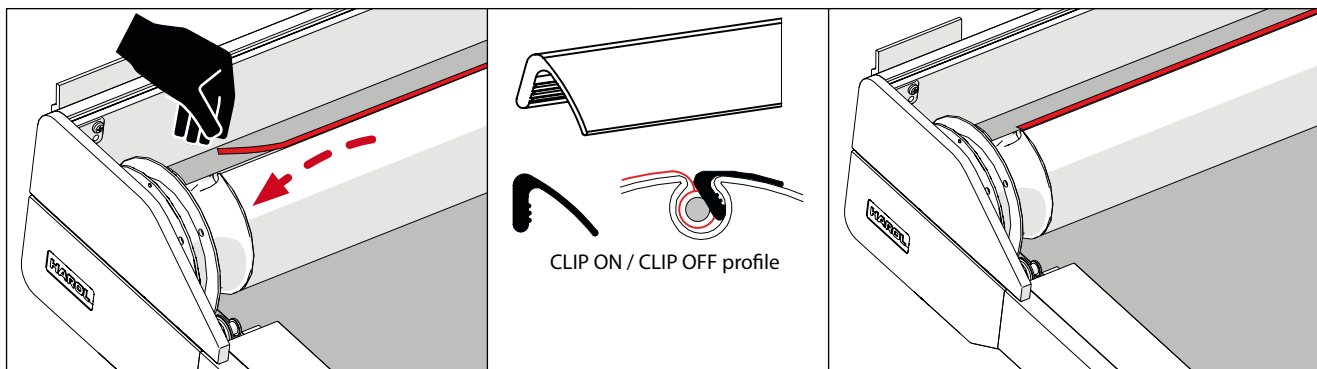

 THE FABRIC MUST BE CENTERED ON THE DRUM!

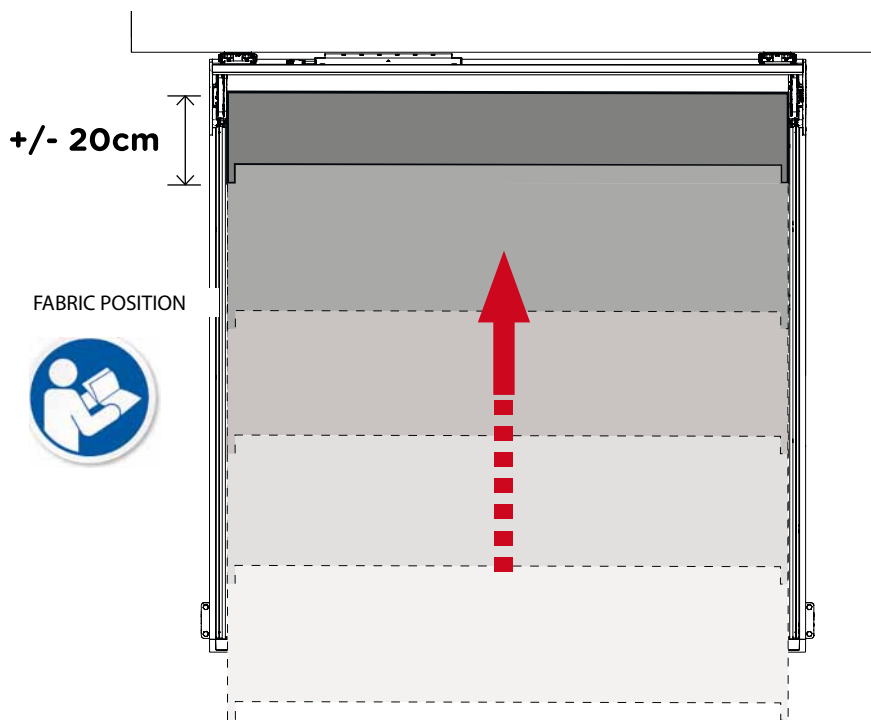
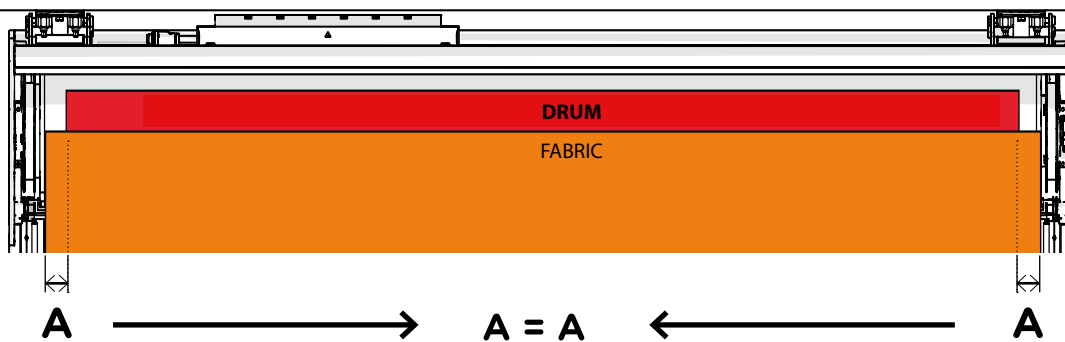

see the Somfy instruction manual

**somfy.**  
www.somfy.com



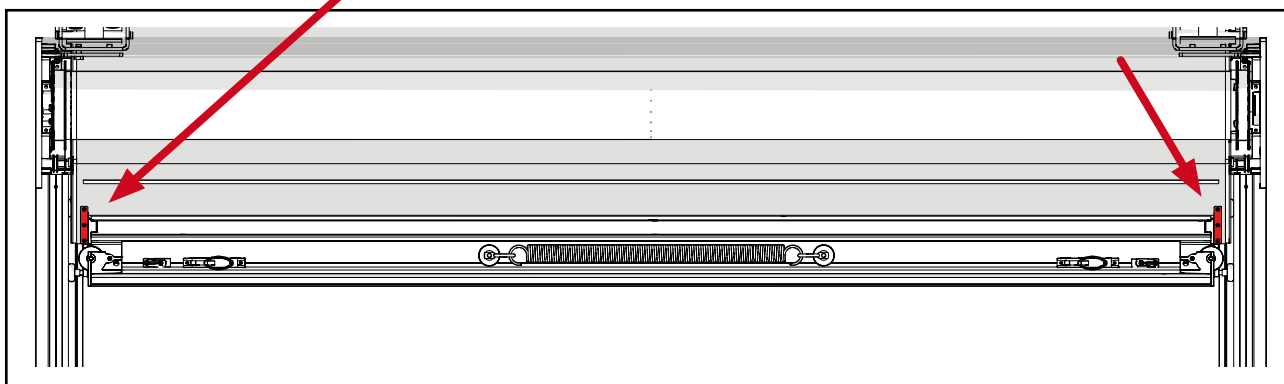
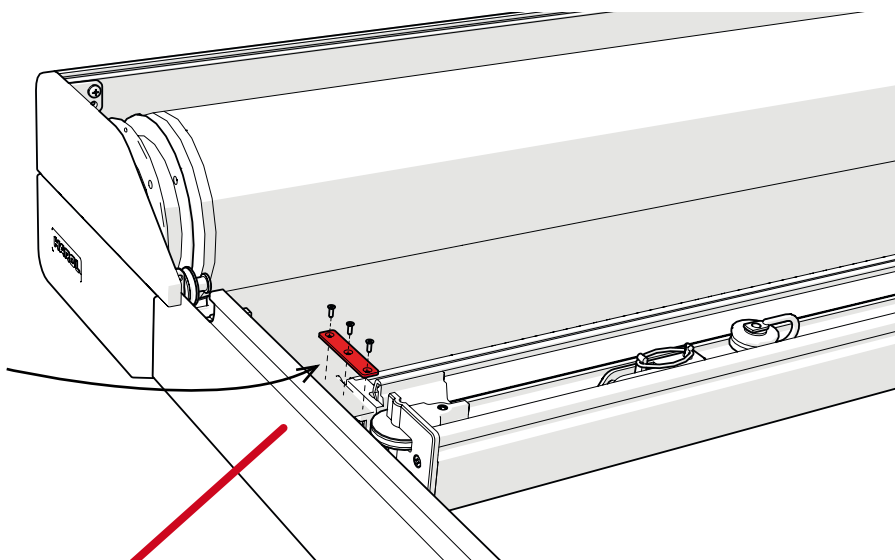
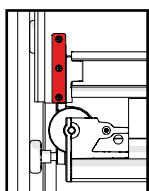
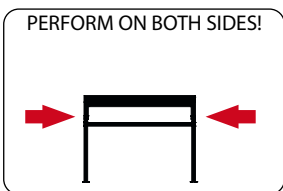
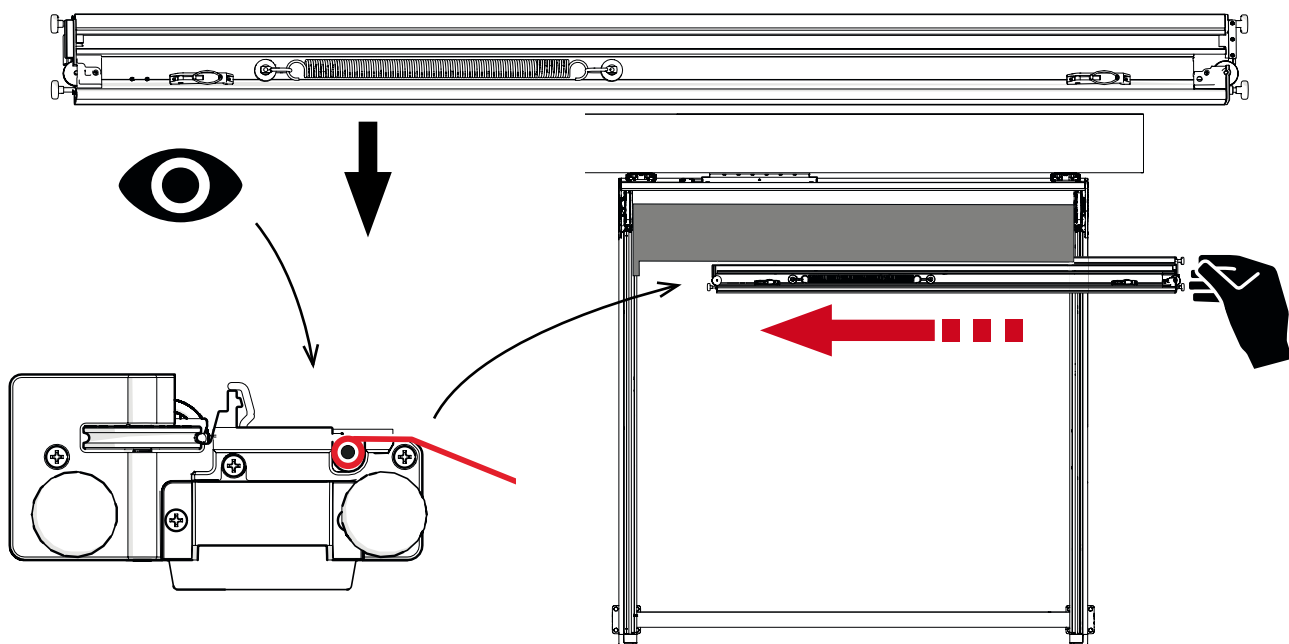

OREA 50 WT  
OREA LT50 RTS  
SUNEA 50 IO

# INSTALLING A NEW FABRIC TO THE DRUM

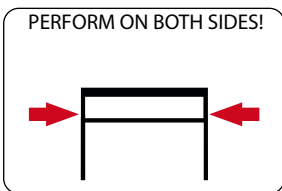

CORD AND KNOT POSITION



 TIE THE KNOT ON THE OUTSIDE!  
TURN THE CORD TWICE ON THE DRUM!

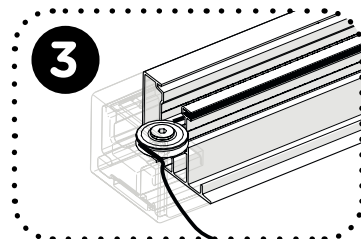
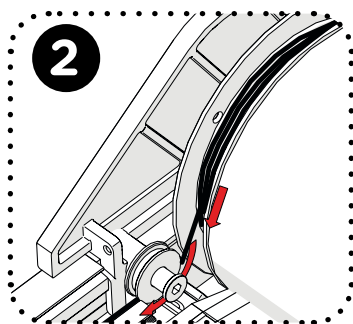
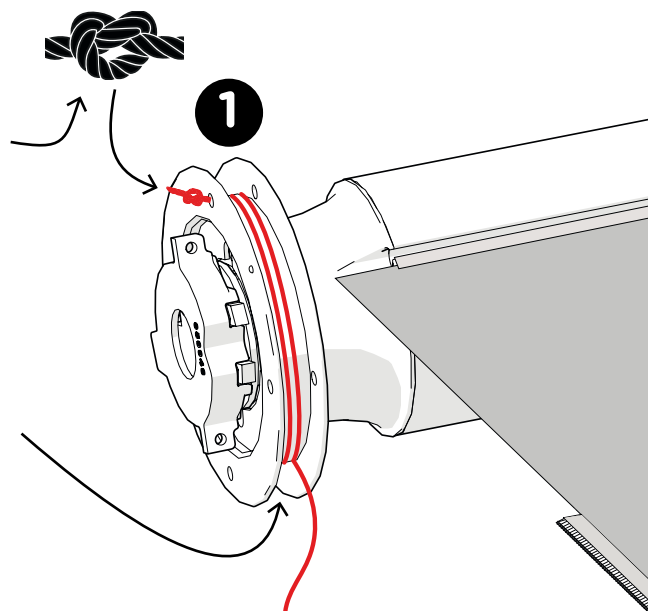

0 - 4000 mm

4001 - 5000 mm

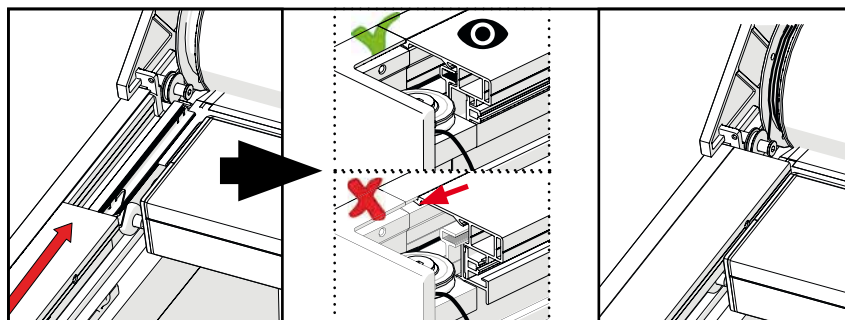
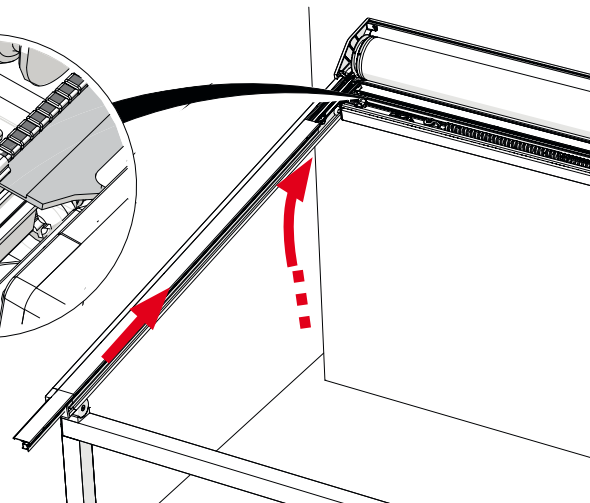
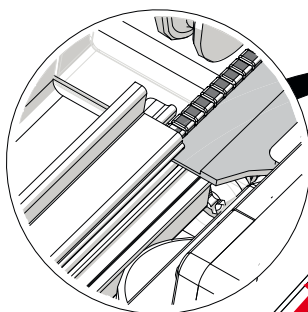
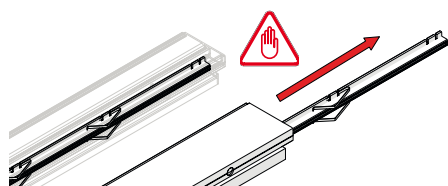

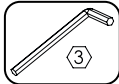

PERFORM ON BOTH SIDES!

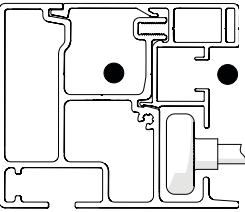
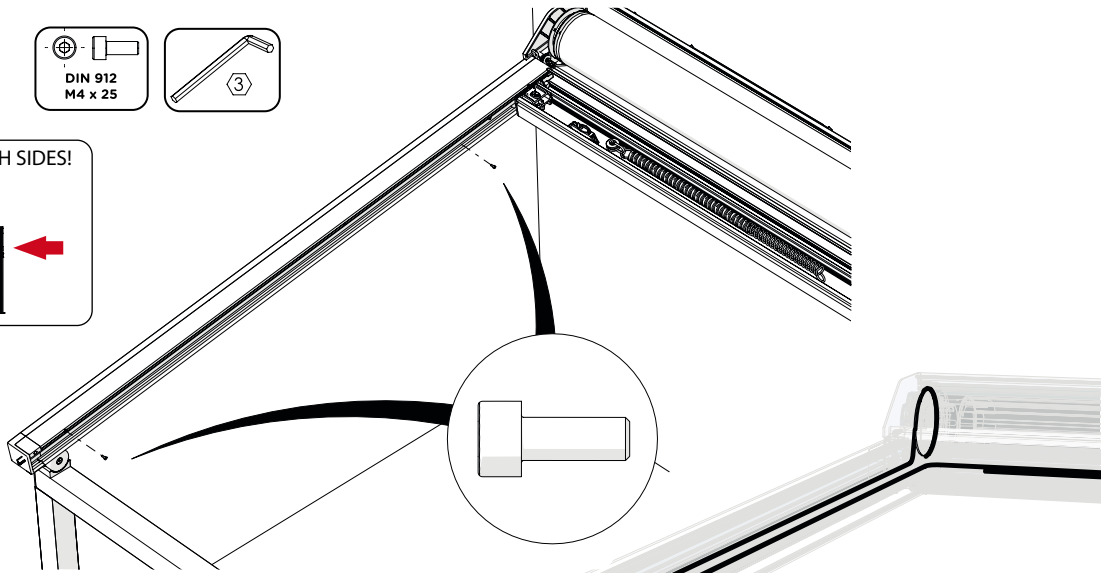

4

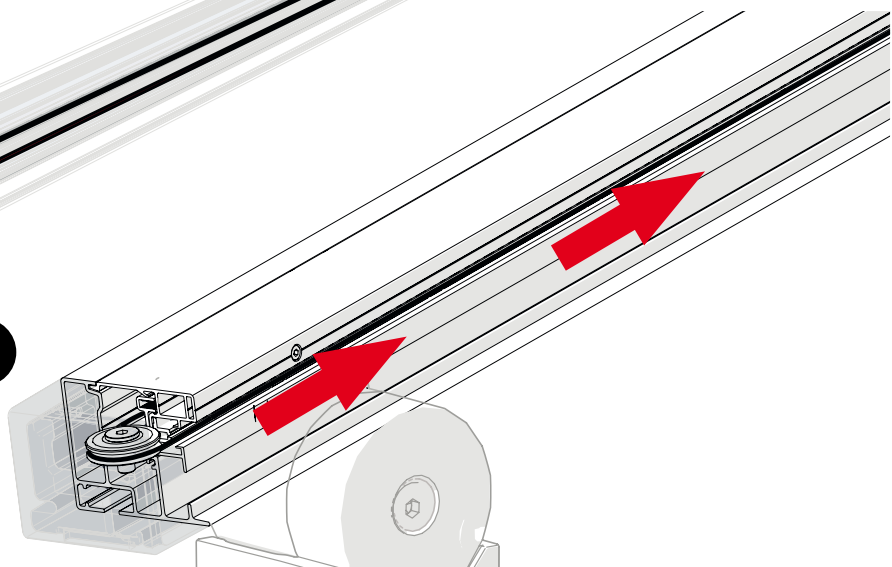

5

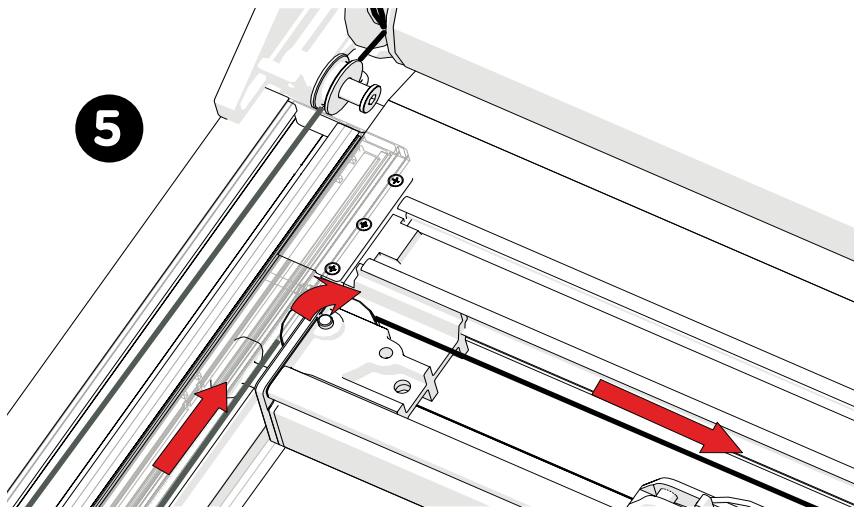

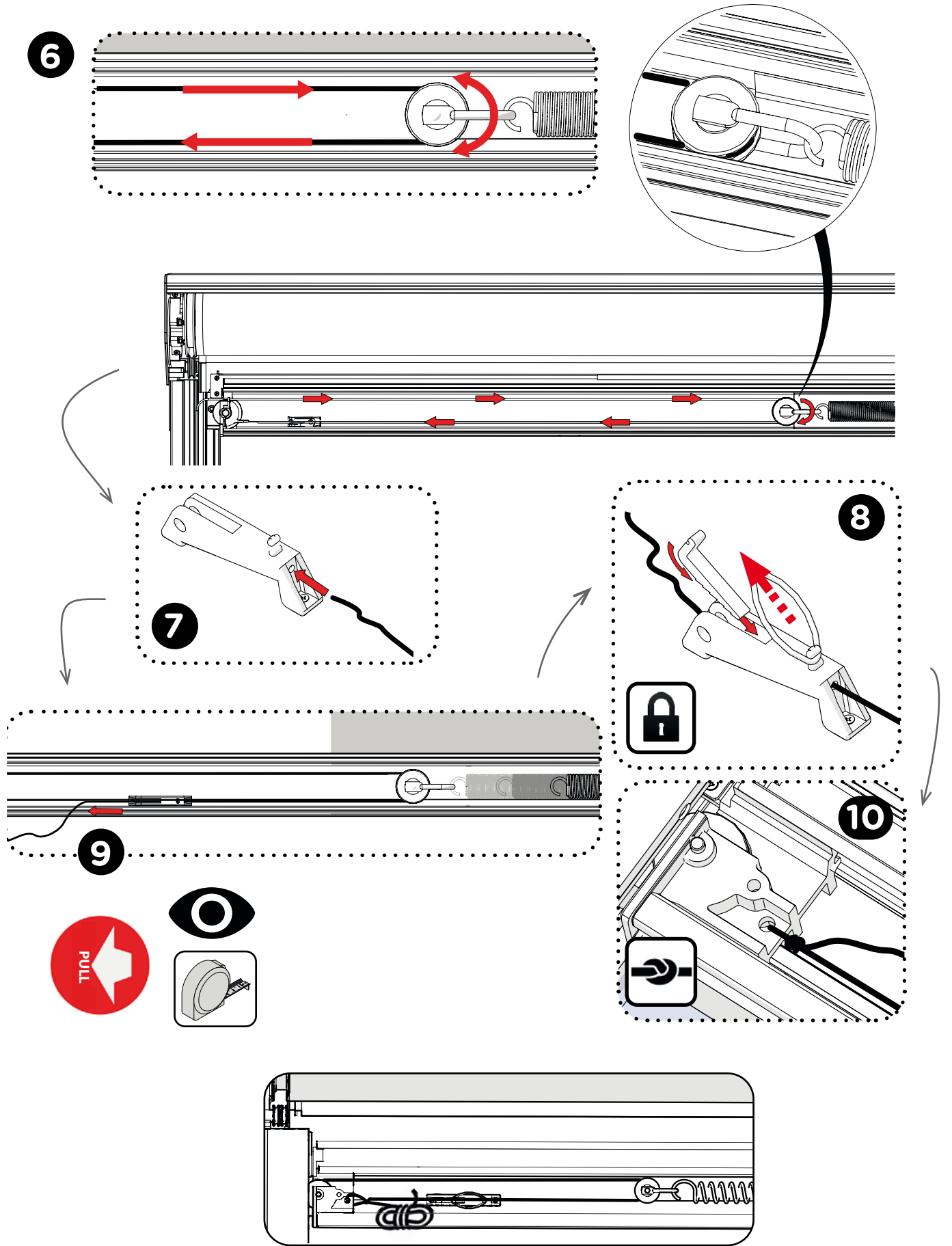

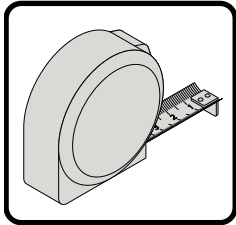
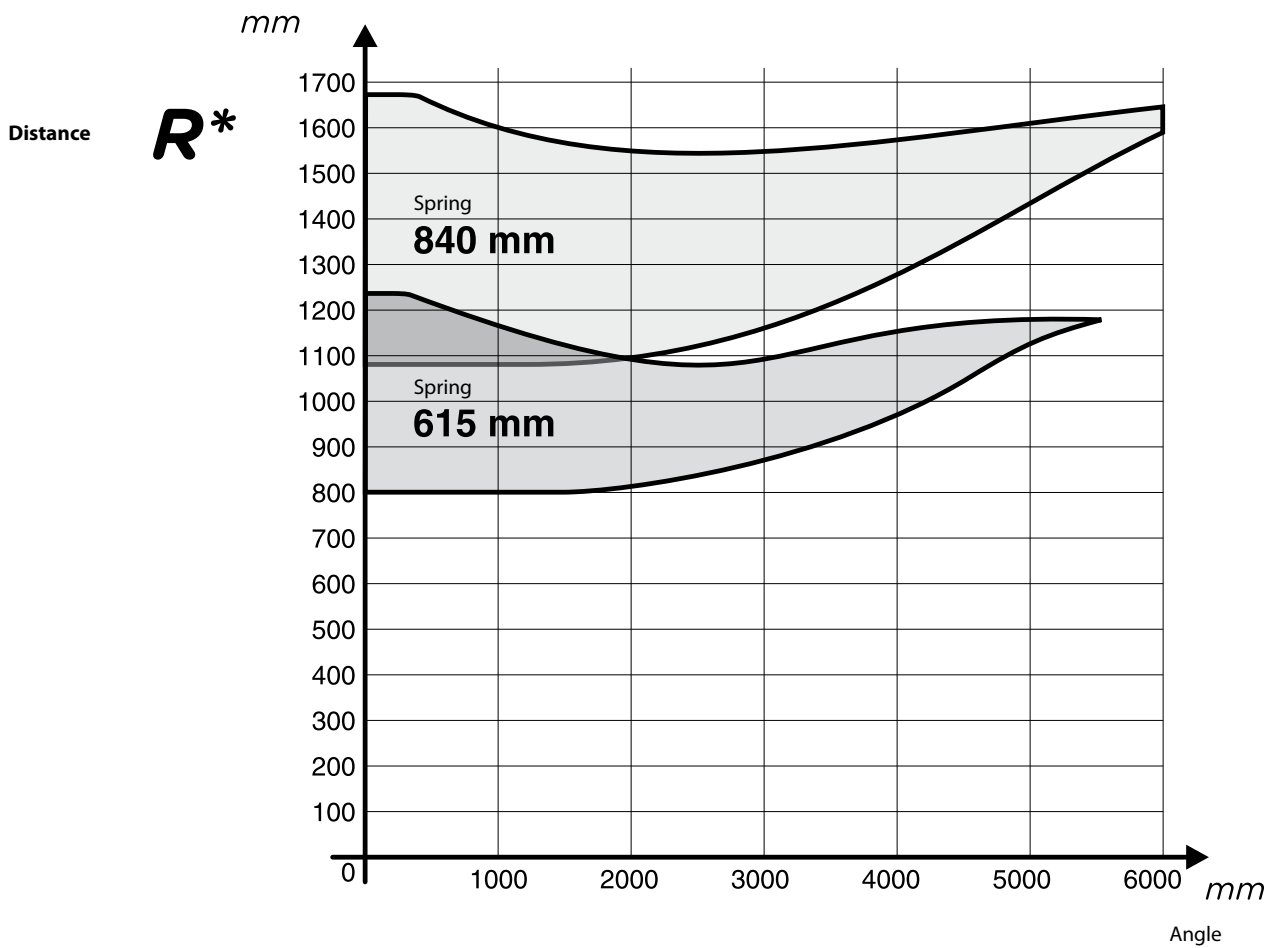
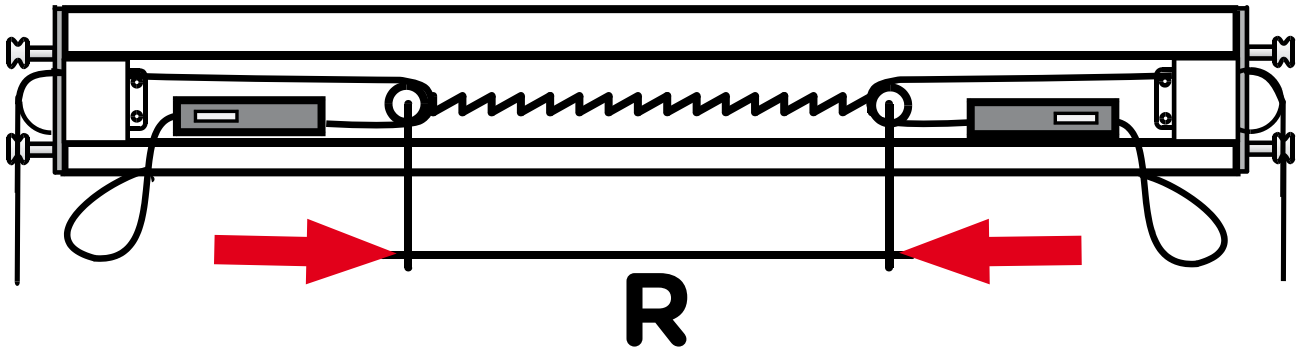
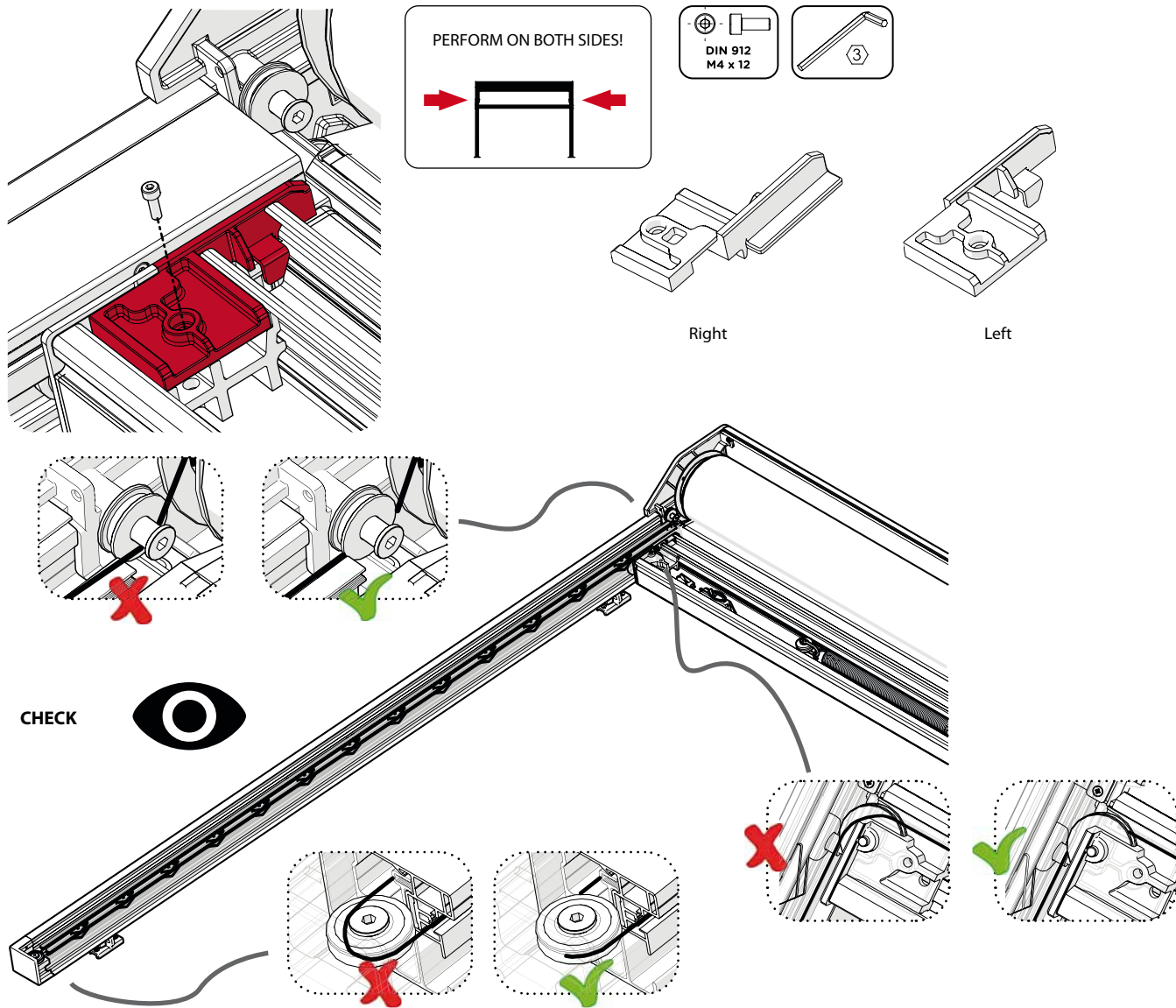

Table of spring distances R (in mm)



\* DEPENDING ON THE SPRING TYPE (650 MM / 850 MM), READ THE DISTANCE R IN THE COLOURED ZONE.





OREA 50 WT  
OREA LT50 RTS  
SUNEA 50 IO





www.somfy.com



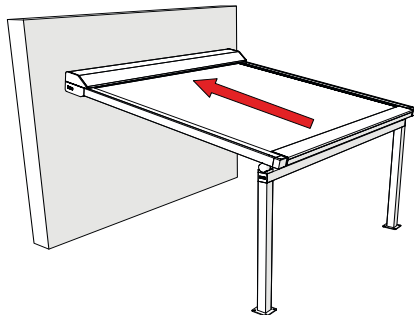
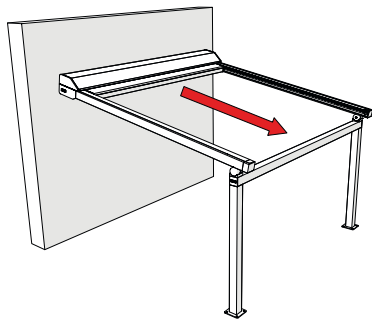
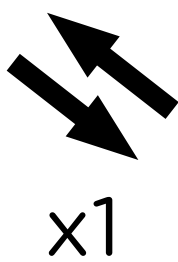

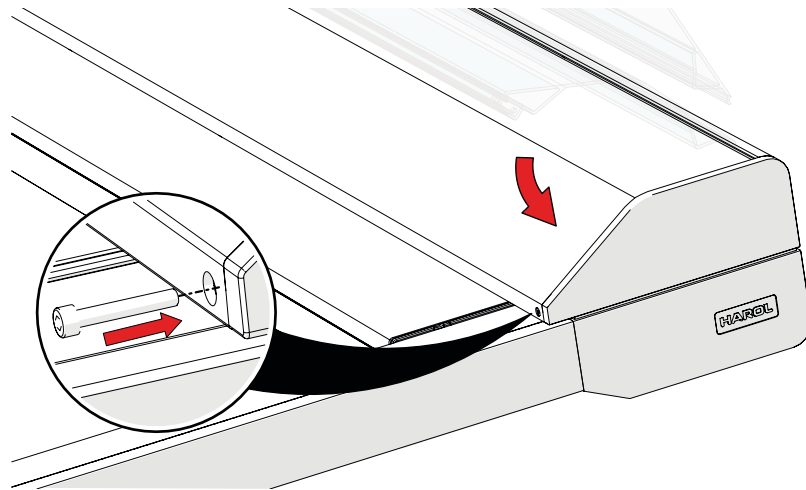
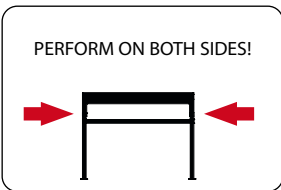
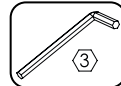
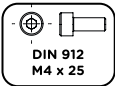
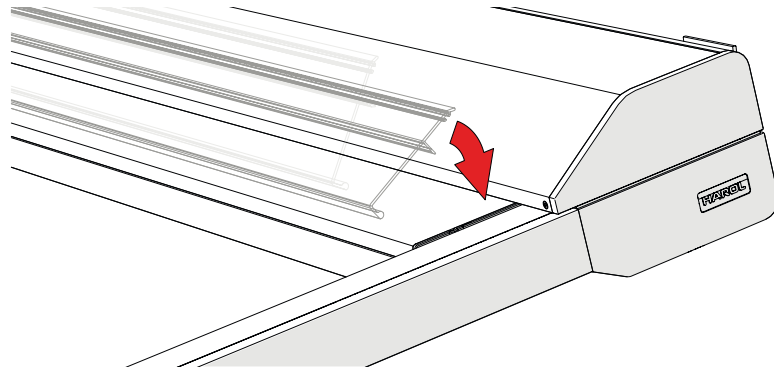
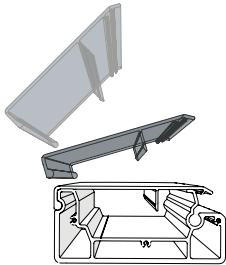
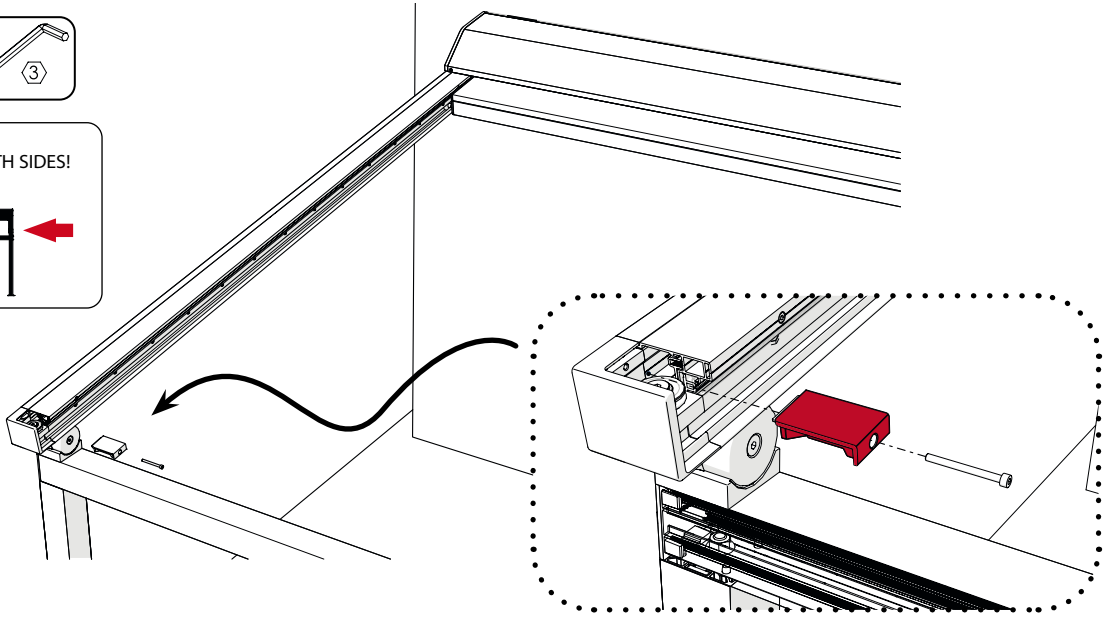
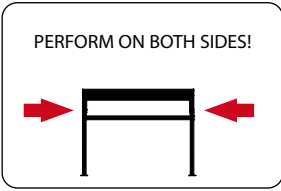
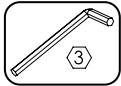
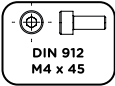

### B) REPLACING THE FABRIC AND MALFUNCTIONING MOTOR

1

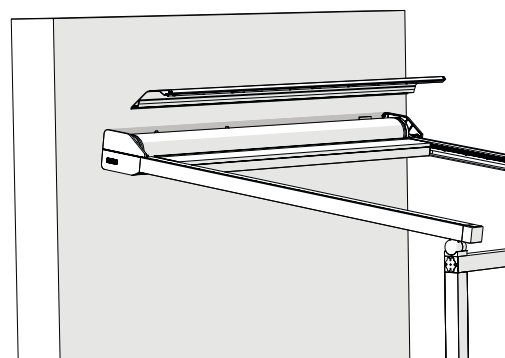
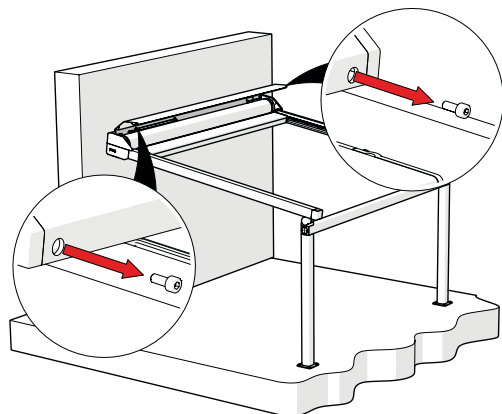
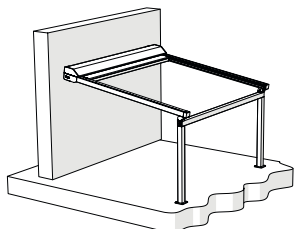
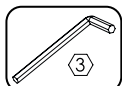
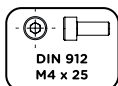

2



REMOVE THE CORD



CAUTION! THE CORD IS TAUT

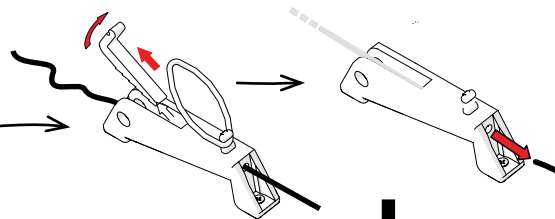
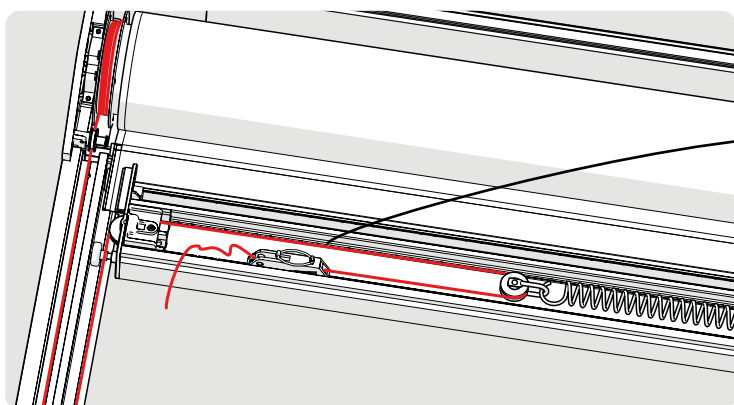
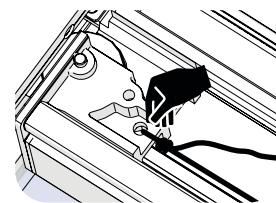
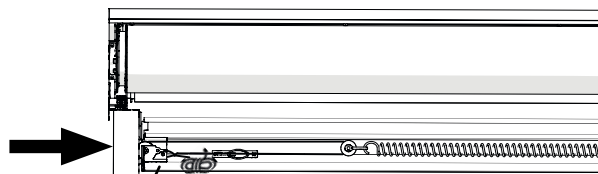
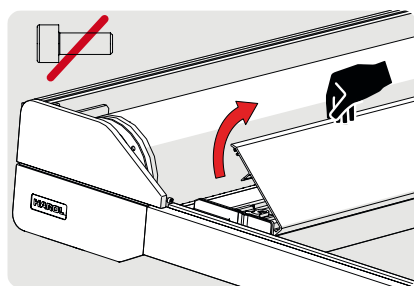
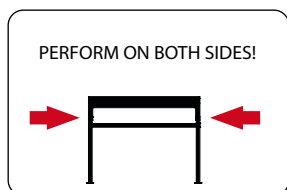

REMOVE THE CORD

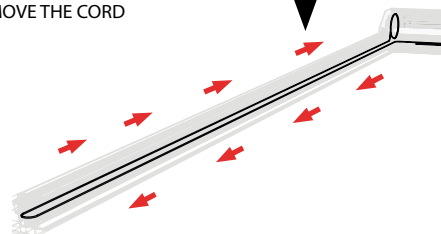

3

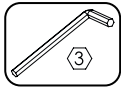
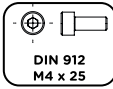

PERFORM ON BOTH SIDES!

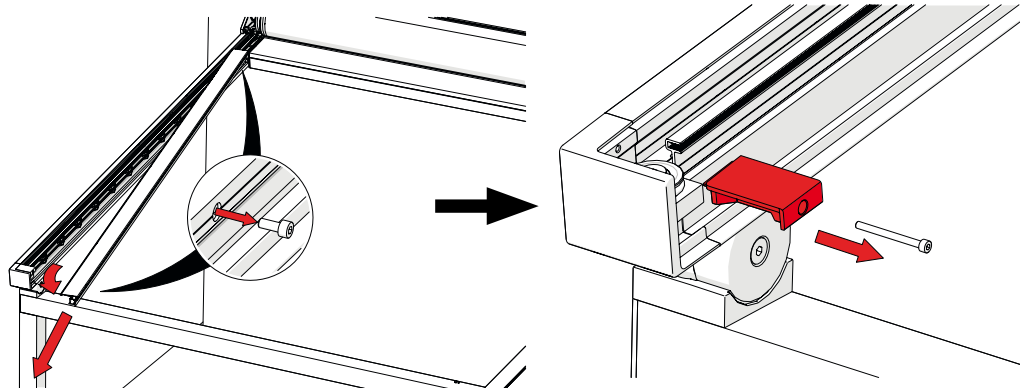

4

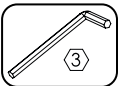
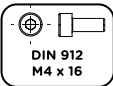

PERFORM ON BOTH SIDES!

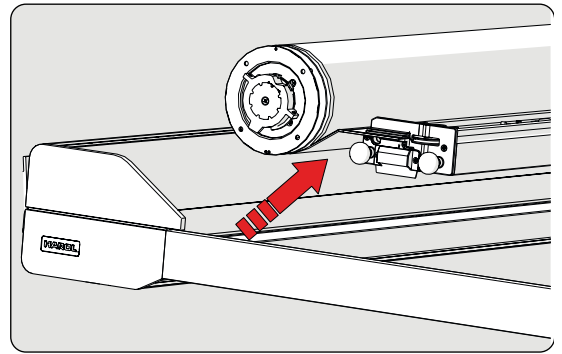
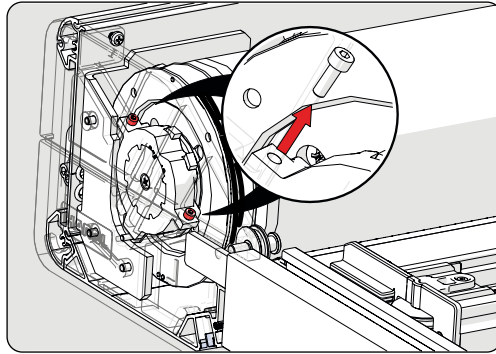

### REPLACING THE FABRIC ON THE DRUM

REMOVE THE FABRIC.

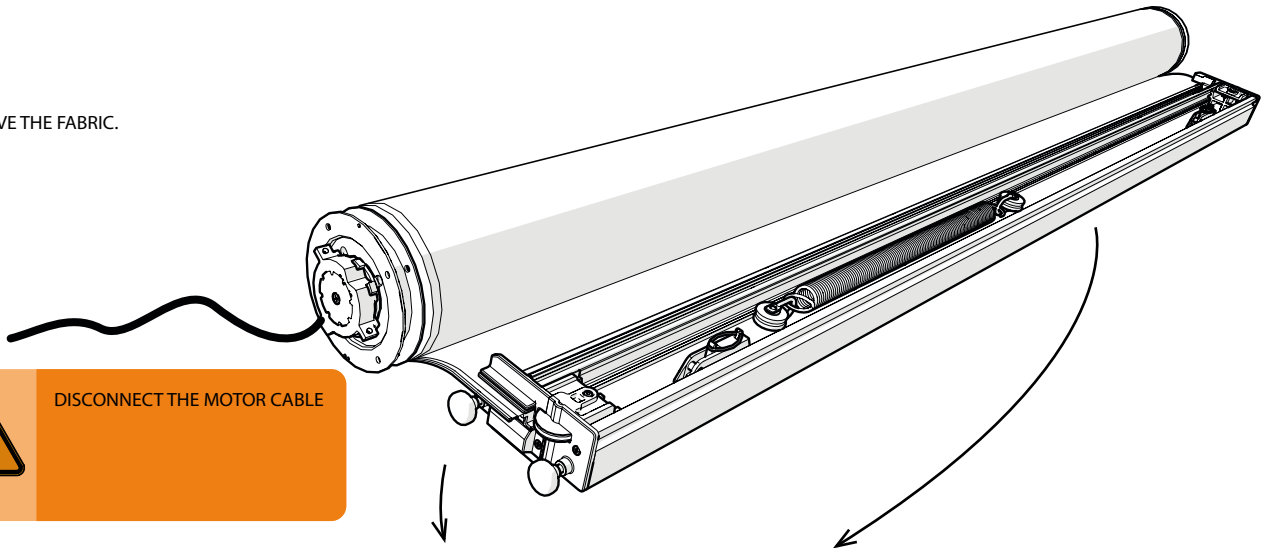

DISCONNECT THE MOTOR CABLE

PERFORM ON BOTH SIDES!

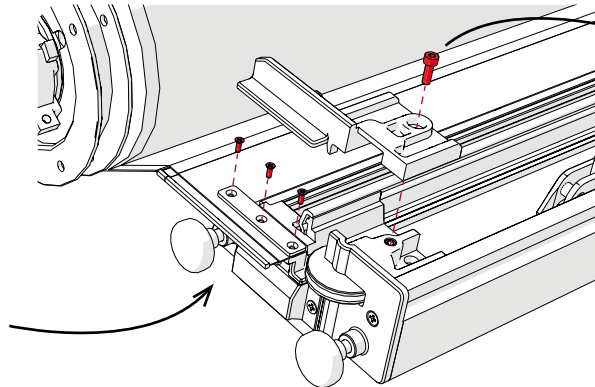
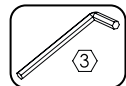

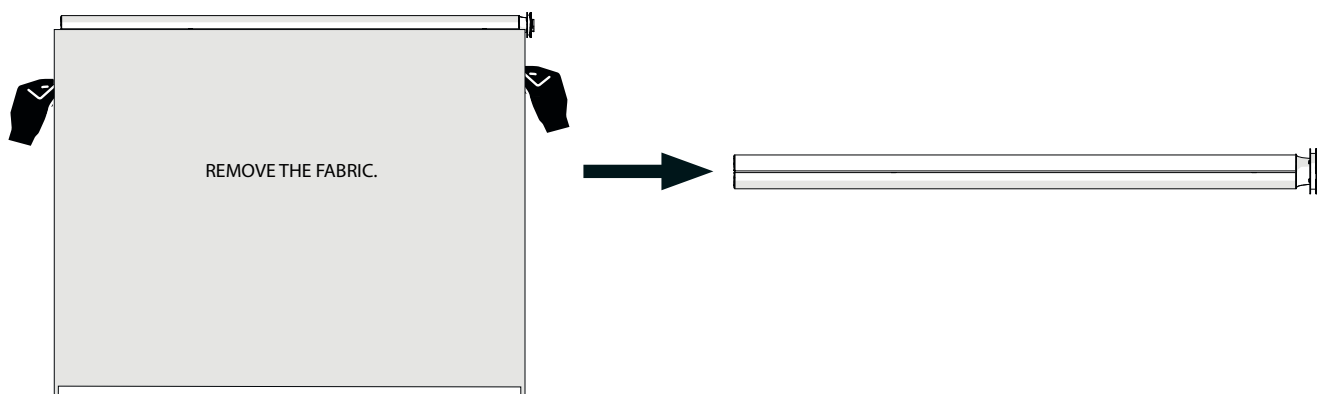
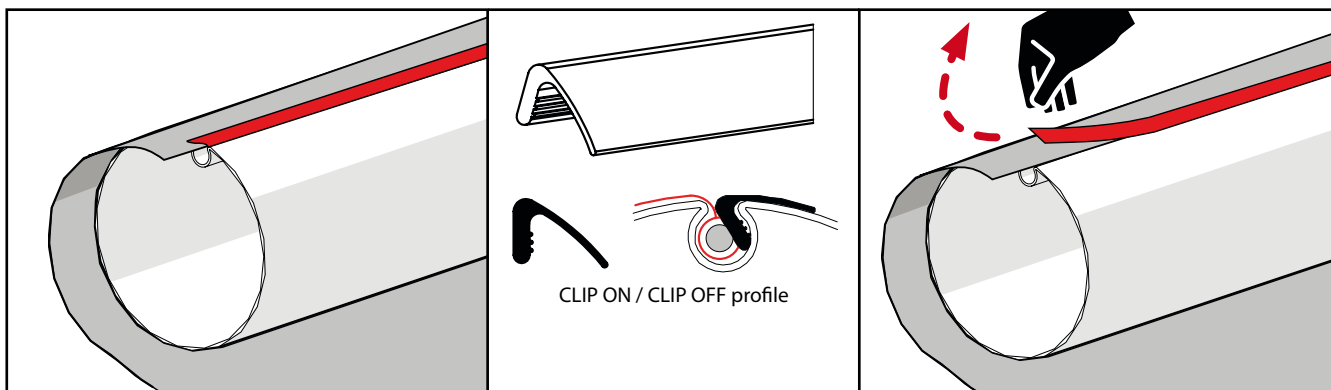
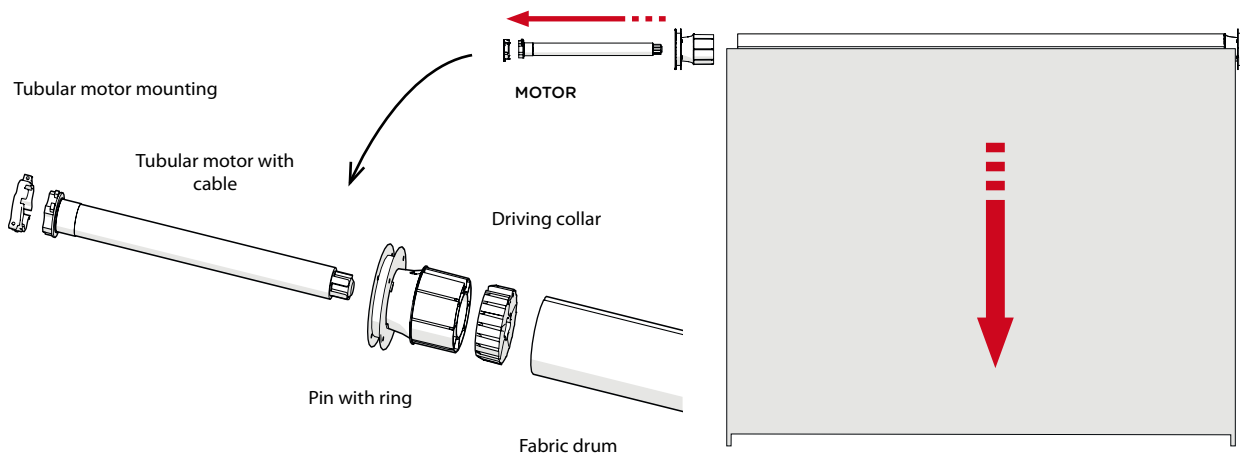
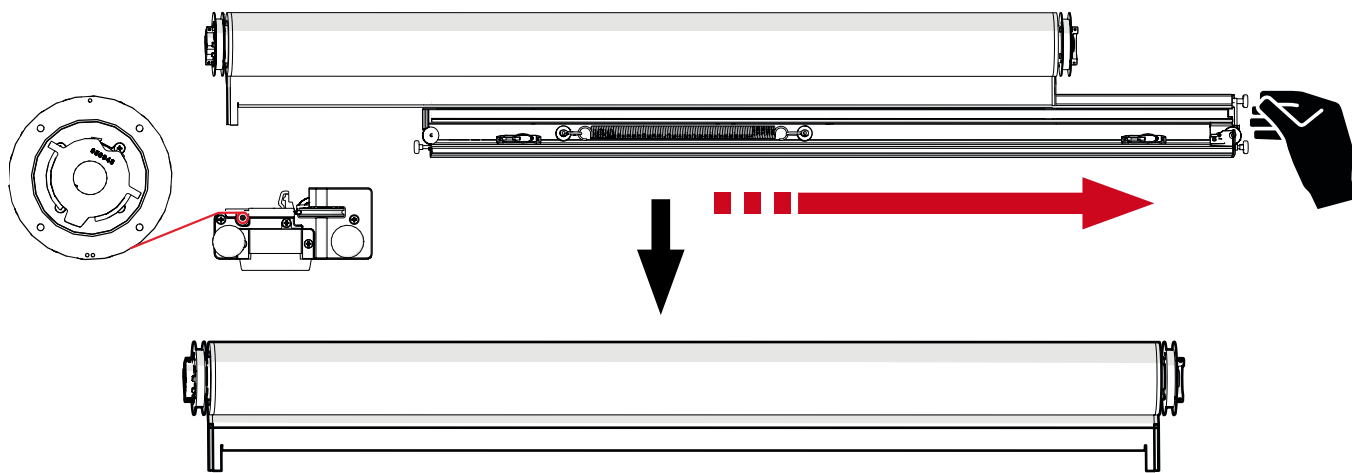

**INSTALLING A NEW MOTOR AND FABRIC TO THE DRUM**

PLACE THE NEW FABRIC

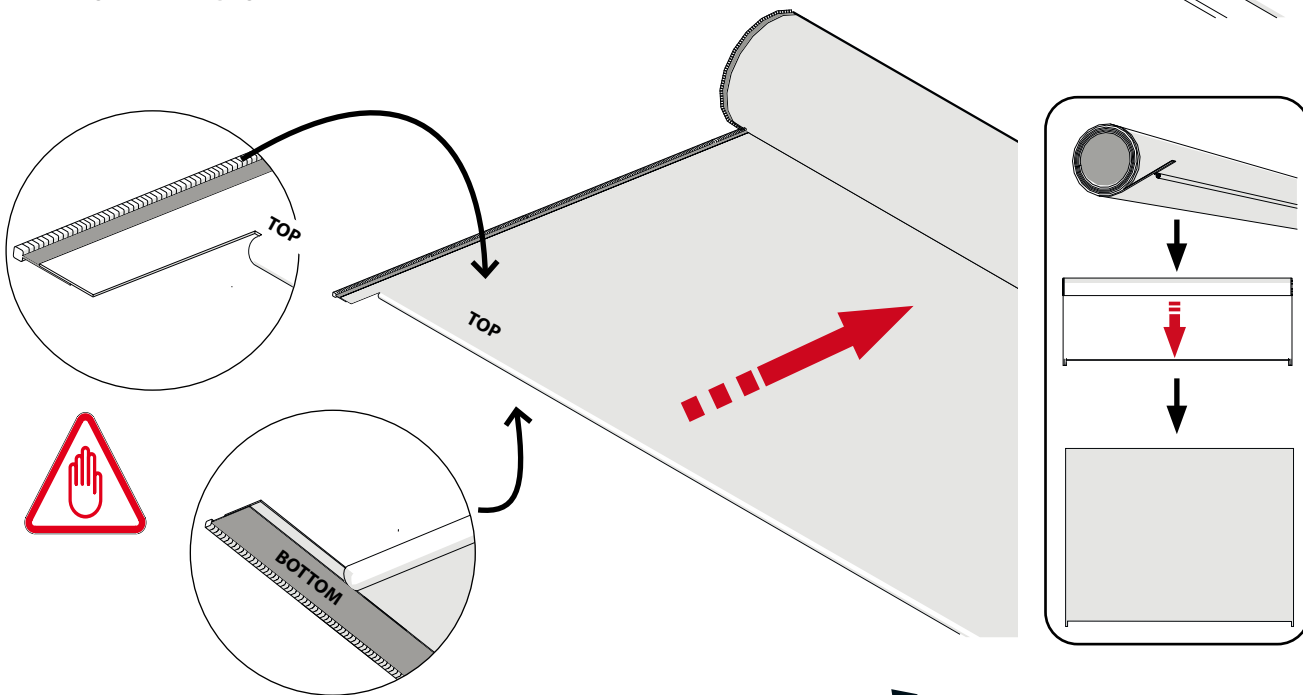

Tubular motor mounting

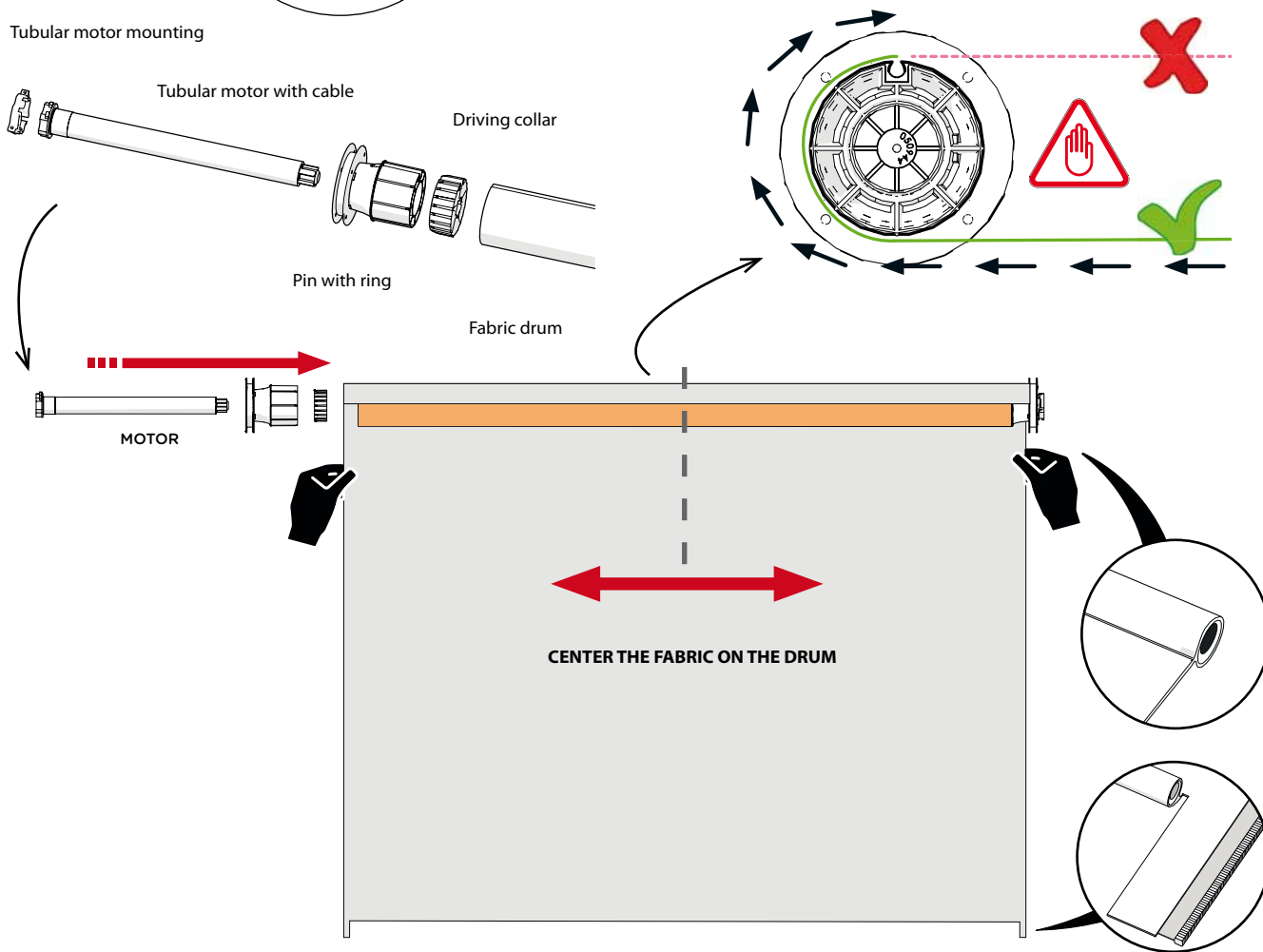

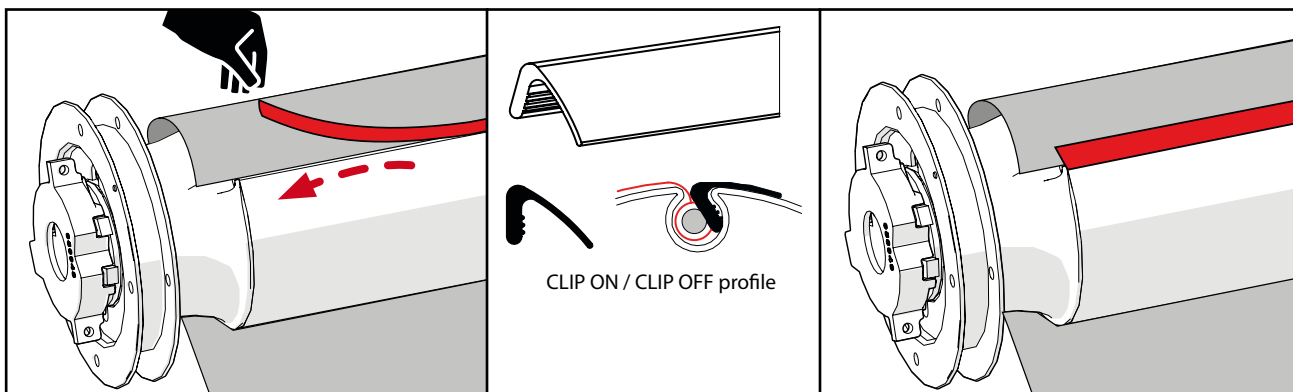

 THE FABRIC MUST BE CENTERED ON THE DRUM!

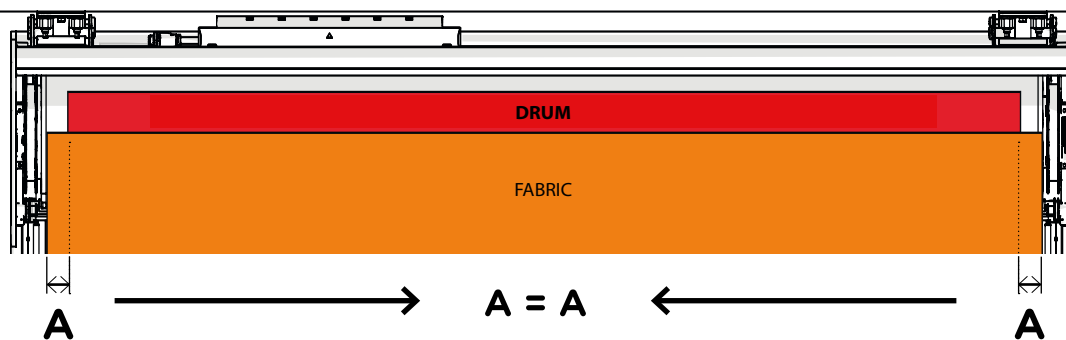

INSTALL THE CORD



 TIE THE KNOT ON THE OUTSIDE!

TURN THE CORD TWICE ON THE DRUM!

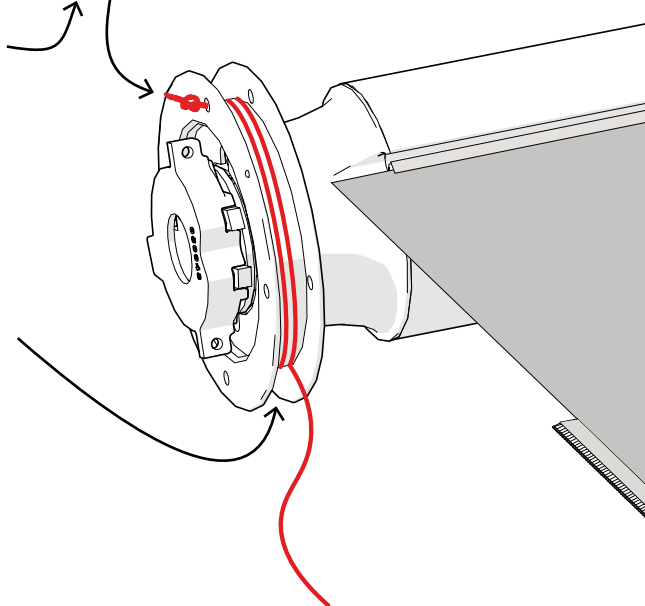

PERFORM ON BOTH SIDES!



# REPLACE THE DRUM

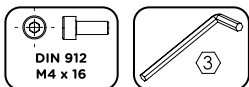
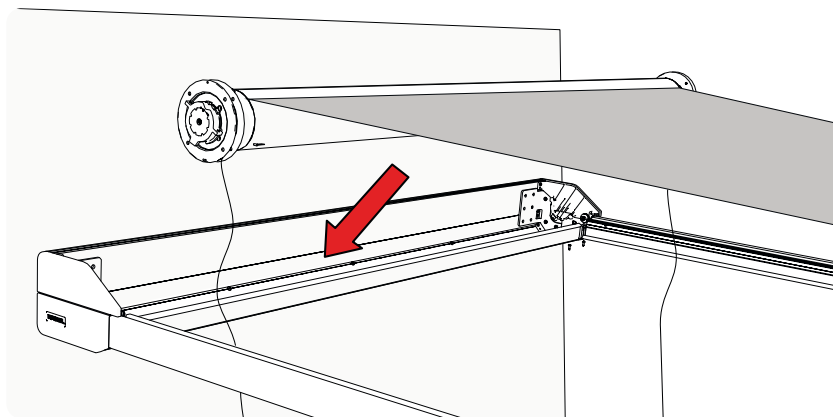

PERFORM ON BOTH SIDES!

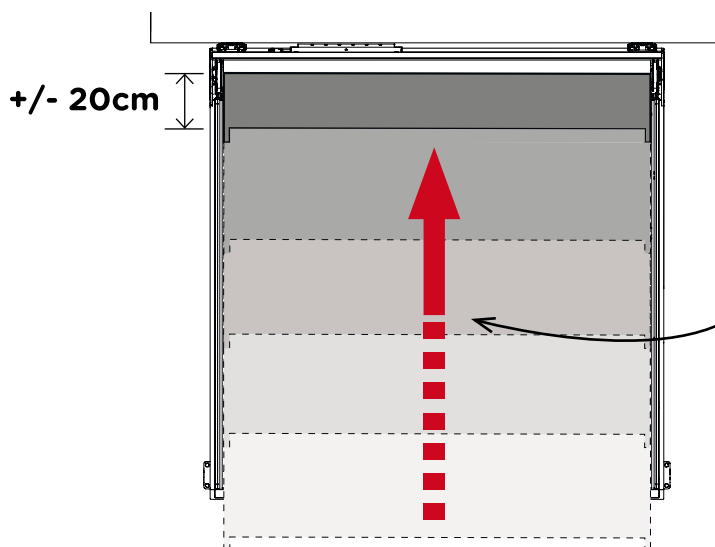
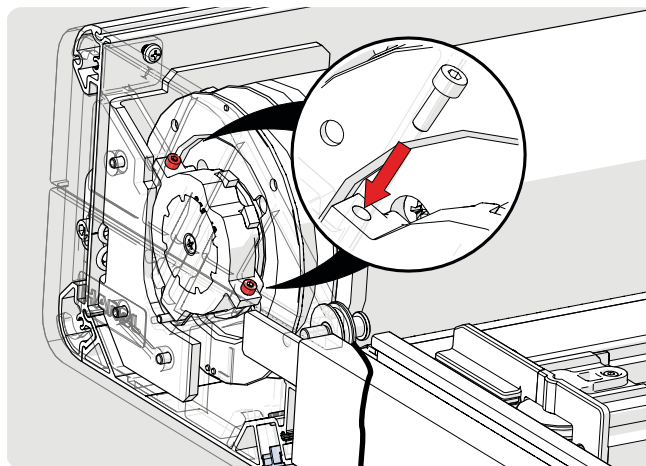

**somfy.**  
[www.somfy.com](http://www.somfy.com)



OREA 50 WT  
OREA LT50 RTS  
SUNEA 50 IO



see the Somfy instruction manual





**ISOTRA a.s.**

Bílovecká 2411/1, 746 01 Opava  
Czech Republic

Tel.: **+420 553 685 111**  
E-mail: [isotra@isotra.com](mailto:isotra@isotra.com)

**[www.isotra.com](http://www.isotra.com)**

Released: 04/2026

**ISOTRA Partner**



*... a touch of intimacy.*